



# **V9 SeriesControl Cabinet User Manual**



**Ver Number: V1.1**

# Content

<b>Content</b> .....	<b>1</b>
<b>FOREWORD</b> .....	<b>9</b>
<b>Chapter 1 SAFETY INFORMATION</b> .....	<b>10</b>
1.1. LABEL DESCRIPTION .....	10
1.2. SAFETY PRECAUTIONS CONTENT AND IDENTIFY LOCATION .....	13
<b>Chapter 2 Introduction and Installation</b> .....	<b>14</b>
2.1. System Composition and Model Description.....	14
2.2. Nameplate Information .....	15
2.3. Specifications .....	16
2.4. Appearance and External Dimension.....	18
2.5. Cabinet Installation Type .....	19
2.6. Confirmation upon Delivery.....	19
2.7. Installation .....	19
2.7.1 Installation Site.....	19
2.7.2 Temperature Requirement .....	20
2.7.3 Protect the controller from Foreign Object .....	20
2.8. Braking Resistor Configuration .....	20
2.9. Product Function.....	21
<b>Chapter 3 Wiring</b> .....	<b>29</b>
3.1. Elevator Integrated Controller Terminal Wiring Diagram.....	29
3.2. Wiring Main circuit Terminals.....	30
3.2.1 Main circuit structure.....	30
3.2.2 Terminal arrangements for Main circuit.....	30
3.2.3 Main circuit terminal summary and function instruction .....	30
3.2.4 Specifications for main circuit wiring.....	31

---

3.2.5 Main circuit wiring .....	31
3.3. Control Circuit Wiring.....	34
3.3.1. Control Circuit Terminal location .....	34
3.3.2. Control Circuit Terminal Connection.....	35
3.3.3. Control Circuit terminal definition and function description.....	35
3.3.4. Control Circuit terminal wire specification .....	38
3.3.5. Control Circuit I/O interface and wiring.....	38
3.4. PG Card Installation & Wiring ( SPG_V6H ) .....	40
3.5. Precautions with Wiring.....	41
<b>Chapter 4 Digital Operator .....</b>	<b>42</b>
4.1. Key, display and function of Digital Operator .....	42
4.1.1 Operator LED Display .....	42
4.1.2 Operator Keys .....	43
4.1.3 LCD Display.....	44
4.1.4 Function of Operator .....	44
4.1.5 Installation and Connection of Digital Operation .....	45
4.2. Structure and Switch process of the Operator Interface.....	46
4.3. Parameter Setting .....	47
4.4. Commissioning Parameters .....	48
4.5. Save Parameter .....	50
4.6. Hoistway Learning.....	51
4.7. Motor Auto-tuning.....	51
4.8. Motor Load Tuning.....	52
4.9. Time Setting .....	52
4.10. Fault Record Check.....	53
4.11. Environment Initialization.....	54

4.12. Parameter Copy .....	55
4.13. Restore to Factory Setting .....	56
4.14. Blue-Light Traction machine Parameter Input.....	56
<b>Chapter 5 Parameters .....</b>	<b>58</b>
5.1. Parameters Function Classifications .....	58
5.2. Parameters Hierarchical Structure.....	58
5.3. Monitoring Parameters.....	59
5.3.1 Hoistway Location (U0).....	59
5.3.2 Monitoring Parameter for I/O Status, Cabin Signal & Interference Appraisal (U1-U5).....	60
5.3.3 Drive Monitoring Parameters (U6) .....	62
5.4. Parameters setup Function Instruction .....	62
5.4.1 Building Setup Parameters (F0).....	62
5.4.2 Parameters for Running Setup (F1).....	63
5.4.3 Time Setup Parameters (F2).....	66
5.4.4 Input type setup Parameters (F3) .....	68
5.4.5 Service Setup Parameters (F4) .....	69
5.4.6 Motor Setup Parameters (F5-F6) .....	70
5.4.7 Multiple PI Setup Parameters (F7) .....	71
5.4.8 Encoder Setup Parameters (F8) .....	72
5.4.9 Control Setup Parameters (F9).....	72
5.4.10 No-load Compensation Setup Parameters (FA) .....	72
5.4.11 Special Parameters (FC) .....	73
5.4.12 Spare parameters (FD) .....	74
5.4.13 Environment Setup Parameters (A) .....	78
<b>Chapter 6 Parameters Setup .....</b>	<b>79</b>
6.1. Elevator Running Speed Setup.....	79

## Content

---

6.1.1 Elevator Rated Speed, Motor Rated Speed, Encoder pulses Setup .....	79
6.1.2 Inspection Run Speed.....	79
6.1.3 Rescue Speed .....	80
6.1.4 Least Speed .....	80
6.2. Normal Running Speed Curve .....	80
6.3. Elevator Running Timing Diagram.....	81
6.3.1 Timing Diagram for Normal Running .....	81
6.3.2 Timing Diagram for Inspection Running.....	83
6.3.3 Timing Diagrams for Rescue Running .....	84
6.3.4 Timing Diagram for Recalibration Running .....	84
6.4. Door Control.....	85
6.4.1 Door Open/Close Control.....	85
6.4.2 Door Open Holding Time.....	86
6.4.3 Door Control in Attendant and Special use mode .....	86
6.4.4 Door Control in Inspection, Fire mode.....	86
6.5. Homing Function Setup.....	87
6.6. Parking Function Setup .....	87
6.7. Fireman Operation Function Setup.....	87
6.8. Rear Door Control Setup .....	88
6.8.1 Different Mode Selection .....	88
6.8.2 Rear Door Condition Setup .....	89
6.9. Input Type Setup .....	90
6.10. Service Floor Setup .....	91
6.11. Weighing Device Setup .....	91
6.12. Duplex Control .....	92
6.13. Group Control .....	92

---

6.14. Leveling Adjustment Setup .....	93
6.15. Floor Indication Setup .....	93
6.16. Special Function Selection .....	93
6.17. Motor Parameters Speed Setup.....	97
6.18. Elevator Running Speed Setup.....	98
6.19. Speed Control Setup (PI Adjustment) .....	98
6.19.1 Speed Control Setup with Single PI Adjustment .....	98
6.19.2 Speed control Setup with Multi-Section PI Adjustment .....	99
6.20. Load-Compensation Torque Output Setup.....	100
6.21. Encoder Parameters Setup .....	101
6.22. Start without Load Compensation Setup.....	102
6.23. Remote monitor.....	103
6.24. Elevator maintenance .....	103
<b>Chapter 7 Commissioning .....</b>	<b>105</b>
7.1. Important Reminder .....	105
7.2. Inspections before Power On.....	105
7.3. Power on and Inspection .....	106
7.3.1 Things need to confirm before Power On.....	106
7.3.2 Inspection after Power On .....	107
7.4. Parameter Setup .....	108
7.5. Motor Initial Angle Tuning .....	108
7.5.1. Motor Rotation Tuning .....	108
7.5.2. Static Tuning Procedures .....	109
7.6. Inspection Running .....	110
7.6.1 Inspection Running in Machine Room .....	110
7.6.2 Inspection Running on Car Top/Cabin .....	111

---

7.7. Hoistway Learning.....	111
7.8. Normal Speed Running .....	112
7.9. Elevator Comfort Level Adjustment.....	112
7.9.1 Adjustment for Start/Brake speed curve .....	112
7.9.2 Follow & Adjust Running Curve.....	113
7.9.3 Control Timing Adjustment.....	114
7.10. Leveling Precision Adjustment.....	114
7.10.1 Basic Conditions for Elevator Leveling .....	114
7.10.2 Leveling Parameter Adjustment .....	114
7.11. Terminal Switch Position.....	115
<b>Chapter 8 Troubleshooting .....</b>	<b>116</b>
8.1. Elevator System Faults.....	116
8.2. Hoistway Parameter Self-Learning Faults.....	129
8.3. Driver Faults.....	131
8.4. Motor Initial Angle Tuning Faults.....	138
8.5. Motor Parameters Tuning Faults .....	142
<b>Chapter 9 Maintenance .....</b>	<b>143</b>
9.1. Safety Precautions for Drive Maintenance & Storage .....	143
9.2. Daily Check.....	144
9.3. Routine Inspection .....	144
9.4. Quick Wear parts .....	145
9.5. Warranty .....	145
<b>Chapter 10 Controller installation with EMC Standard.....</b>	<b>146</b>
10.1. EMC Briefing.....	146
10.2. EMC Characteristics of Integrated Controller .....	146
10.3. EMC Installation Guide.....	146
10.3.1 Noise Control .....	146

10.3.2 Wiring.....	147
10.3.3 Ground Connection.....	147
10.3.4 Leakage Current.....	148
10.3.5 Power Line Filter.....	148
10.4. EMC standard satisfied by Integrated Controller.....	149
<b>Chapter 11 Accessories.....</b>	<b>150</b>
11.1. iBL6-KIO-V6.2 Cabinet Interface Board.....	150
11.2. iBL6-DIO-V6.x Car Top Interface Board.....	159
11.3. POBK Serial Brake Power Board.....	166
11.4. SJT-OVP-V2A Overvoltage Protection Board.....	170
11.5. BL2000-JDB-V6.4 Car Top Board.....	171
11.6. BL2000-ZLB-V6.x Car Instruction Board.....	175
<b>Appendix 1 Hoistway Switches Information (Partly).....</b>	<b>178</b>
F1.1 Leveling Switches & Flag Installation.....	178
F1.2 Up/Down Terminal Switches Installation.....	178
F1.3 Confirm the Terminal Switches Location.....	179
<b>Appendix 2 Re-Leveling &amp; Door Open in Advance.....</b>	<b>180</b>
F2.1 Safety Control Board (SJT-ZPC-V2A) Drawings.....	180
F2.2 Safety Control Board Terminal Definition.....	180
F2.3 Re-Leveling & Door Open in Advance Wiring Diagram.....	181
F2.4 Installation for Re-Leveling Door Zone Switches.....	181
F2.5 Main Control Board Parameters Setup.....	182
F2.5.1 Enable this function in Special function list.....	182
F2.5.2 Running Parameters Setup.....	182
<b>Appendix 3 Parameters List.....</b>	<b>183</b>
<b>Appendix 4 Emergency Leveling Function.....</b>	<b>188</b>
F4.1 Emergency Leveling Device Model.....	188

F4.2 Emergency Leveling Device Specification .....	188
F4.3 Caution .....	188
<b>Appendix 5 Star-Sealed &amp; Running Contactor .....</b>	<b>189</b>
<b>Appendix 6 V9 Series Elevator Integrated Controller Intensive Serial Communication Resolution .</b>	<b>190</b>
<b>Appendix 7 Menu operation processes with 4 Digital tubes &amp; 3 operation keys .....</b>	<b>192</b>
<b>Appendix 8 Separated Detection of hall door and car door for V9.....</b>	<b>203</b>
<b>Appendix 9 Simple rated slip tuning for geared motor.....</b>	<b>205</b>
<b>Appendix 10 V9 Series Elevator Integrated Controller UCMP ( Unintended Car Movement Protection ) Function Testing Procedure.....</b>	<b>206</b>
<b>Appendix 11 V9 Series Elevator Integrated Controller Rope Slipping Mode Testing.....</b>	<b>216</b>
<b>Appendix 12 Floor/Car Door Short-circuited Detection and The Plan for Bypass Operation Alarm.</b>	<b>217</b>
<b>Appendix 13 Leveling Adjustment inside The Car .....</b>	<b>227</b>
<b>Appendix 14 Evacuation Operation of Generator .....</b>	<b>228</b>
<b>Appendix 15 VIP Function .....</b>	<b>230</b>
<b>Appendix 16 Earthquake Operation .....</b>	<b>231</b>
<b>Appendix 17 Australian Fire Fighting Mode .....</b>	<b>232</b>
<b>Appendix 18 Using the Main Board Keypad to Carry Out self-learning operation process.....</b>	<b>233</b>
<b>Appendix 19 Direction and Speed Display when Electrical Release Brake and Car Slide .....</b>	<b>235</b>
<b>Appendix 20 Forced Drive Mode Elevator Instruction .....</b>	<b>236</b>
<b>Appendix 21 Integrated Controller Manual Door Solution .....</b>	<b>237</b>

## FOREWORD

Thank you for using V9 series villa lift control cabinet. V9 series villa lift control cabinet is new generation control cabinet for villa lift. It combines elevator intellectual logic control and high-performance VVVF drive control. With user friendly interface and advanced technology integrated together, the system not only has outstanding performance, but also shows strong reliability in practice.

- ◆ The system combines intellectual logic control and high-performance VVVF drive control.
- ◆ Adopts advanced vector control technology, demodulates motor with high precision, takes full advantage of motor capacity, improves elevator performance and comfort feel.
- ◆ Adopts advanced space vector PWM calculation method, compare with traditional sine/cosine PWM method, it improves elevator operation efficiency and saves more energy.
- ◆ Adopts full function of BL2000/3000 system, maximize the performance of elevator in different application.
- ◆ When using the Synchronous machine, controller could pre-define the machine type with the most optimized model, save machine parameter input and auto-tuning process, improves the commissioning efficiency and maximize the machine performance.
- ◆ Fuzzy logic control with non-load-compensation start-up. Excellent comfort feels without lift weighing device.
- ◆ Rotating or static auto-tuning to get motor parameters and initial angle.
- ◆ Suitable for both gearless PM Synchronous traction machine and asynchronous induction machine.
- ◆ Brake units are built in for the whole V9 series to reduce external component cost.
- ◆ Internal encoder and frequency dividing interface to match different PG signal.
- ◆ Advanced double 32-bit CPU and FPGA for complete elevator control, with high reliability on elevator safety.
- ◆ Redundancy design and full software-hardware protection to achieve elevator safety and reliability.
- ◆ Passed professional EMC test, suitable for complicated job site.
- ◆ Monitor the cutting current from controller to main motor every time elevator stops.
- ◆ Generate optimized speed curve based on target floor to enable lift stop directly with high efficiency.
- ◆ CAN BUS serial communication technology with high speed and reliability. Simplify system wiring/extension.
- ◆ Adopts wireless/LAN remote control interface, convenient for long distance commissioning, maintenance and elevator monitoring.
- ◆ Equips upper monitoring and software, convenient for parameter setting, commissioning and debugging.
- ◆ Data recorder to save integrated controller operation data, help for onsite maintenance /trouble shooting.
- ◆ Parameter upload, download and copy to help onsite maintenance.
- ◆ Support ARD function with only UPS unit.
- ◆ Match GB 7588-2003 (equivalent to EN-81) safety standard.

This user guide has introduced on how to use V9 series villa lift control cabinet. Please read it carefully and understand safety items before use (installation, running maintenance). This user guide is for elevator designer, installation and maintenance technician. The installation, commissioning and maintenance must be performed by train technician.

The intellectual property of this user guide is owned. Any information from this user guide should not be copied without permission.

## Chapter 1 SAFETY INFORMATION

### 1.1. LABEL DESCRIPTION

The following conventions are used to indicate precautions in this user guide. Failure to notice the precautions provided in this user guide can result in serious or even fatal injury to damage to the products or to related equipment and systems.



Indicates precautions that if not heeded could possibly result in loss of life or serious injury.



Indicates precautions that if not heeded could result in relatively serious or minor injury to the operator and damage to the product. Also, it should be noted that even for  precautions, in certain situations could result in serious accident.



Indicate important information that should be memorized.

#### ◆ Confirmation upon Delivery



- ✧ **Never install an integrated controller that is damaged or missing components.**  
Otherwise it will cause injury.

#### ◆ Installation



- ✧ **Always hold the case when carrying the integrated controller**  
Otherwise the integrated controller may drop and damage.
- ✧ **Please install the device to a metal surface or other non-flammable objects**  
Otherwise there is a fire-hazard potential.
- ✧ **Please mount the device to an object that is strong enough.**  
Otherwise the integrated controller may drop and damage.
- ✧ **Please install the device in a dry place where water or rain could not get into.**  
Otherwise the integrated controller could get damaged.
- ✧ **For the same cabinet to install the integrated controller and brake resistor, install cooling fan or other cooling device and make sure the air temperature entering is below 45°C**  
Overheat can result in fires or other accidents.
- ✧ **Do not install the device in the environment containing flammable, explosive gas or nearby.**  
Otherwise there is risk of fire or explosion.
- ✧ **Do not leave any metallic objects inside the integrated controller**  
Otherwise it may damage the device and has fire-hazard potential.

## ◆ Wiring



- ◇ **Always turn OFF the input power supply before wiring terminals.**  
Otherwise, an electric shock or fire can occur.
- ◇ **Wiring must be performed by an authorized person qualified in electrical work.**  
Otherwise, an electric shock or fire can occur.
- ◇ **Be sure to ground the ground terminal. (200 V Class; Ground to 100  $\Omega$  or less, 400 V Class; Ground to 10  $\Omega$  or less)**  
Otherwise, an electric shock or fire can occur.
- ◇ **Always check the operation of any Emergency stop circuits after they are wired.**  
Otherwise, there is the possibility of injury. (Wiring is the responsibility of the user.)
- ◇ **Never touch the output terminals directly with your hands or allow the output lines to come into contact with the Inverter case. Never short the output circuits.**  
Otherwise, an electric shock or ground short can occur.



- ◇ **Check to be sure that the voltage of the main AC power supply satisfies the rated voltage of the Inverter.**  
Injury or fire can occur if the voltage is not correct.
- ◇ **Do not perform voltage withstand tests on the Inverter.**  
Otherwise, semiconductor elements and other devices can be damaged.
- ◇ **Connect braking resistors.**  
Otherwise, a fire can occur and the Inverter.
- ◇ **Tighten all terminal screws to the specified tightening torque.**  
Otherwise, a fire may occur.
- ◇ **Do not connect AC power to output terminals U, V, and W.**  
The interior parts of the Inverter will be damaged if voltage is applied to the output terminals.
- ◇ **Do not connect phase-advancing capacitors or LC/RC noise filters to the output circuits.**  
The Inverter can be damaged or interior parts burnt if these devices are connected.
- ◇ **Do not make terminal DC+ and DC- short link.**  
Otherwise, a fire or explosion may occur.

## ◆ Trial Operation



- ◇ **Check to be sure that the front cover is attached before turning ON the power supply.**  
Otherwise, an electric shock may occur.
- ◇ **Do not get close to machine and related objects when choosing the error auto reset function, as the drive will automatically restart after warning reset.**  
Otherwise, an injury may occur.
- ◇ **Reset alarms only after confirming that the RUN signal is OFF.**  
Otherwise, an Injury may occur.
- ◇ **Do not perform fault operation and signal checking while the drive is running.**  
Otherwise an injury may occur, and the drive may get damaged.

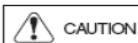

✧ **Do not touch the radiation fins (heat sink), braking resistor, or Braking Resistor Unit. These can become very hot.**

Otherwise, a burn injury may occur.

✧ **Do not touch the braking resistor.**

Doing so can result in electric shock.

✧ **Be careful when changing Inverter settings. The Inverter is factory set to suitable settings.**

Otherwise, the equipment may be damaged.

◆ **Maintenance and Inspection**



✧ **Do not touch the Inverter terminals. Some of the terminals carry high voltages and are extremely dangerous.**

Doing so can result in electric shock.

✧ **Always have the protective cover in place when power is being supplied to the Inverter.**

When attaching the cover, always turn OFF power to the Inverter through the MCCB.

Doing so can result in electric shock.

✧ **After turning OFF the main circuit power supply, wait for the time indicated on the front cover, and make sure the CHARGE indicator light has gone out, and then perform maintenance and inspection.**

The capacitor will remain charged and is dangerous.

✧ **Maintenance, inspection, and replacement of parts must be performed only by authorized personnel. Remove all metal objects, such as watches and rings, before starting work. Always use grounded tools.**

Failure to heed these warning can result in electric shock.

✧ **Do not change the wiring, or remove connectors or terminal, during power on period.**

Otherwise, an electric shock may occur.

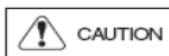

✧ A CMOS IC is used in the control board. Handle the control board and CMOS IC carefully.

The CMOS IC can be destroyed by static electricity if touched directly.

◆ **Other**



✧ Do not attempt to modify or alter the Inverter.

Doing so can result in electrical shock or injury.

## 1.2. SAFETY PRECAUTIONS CONTENT AND IDENTIFY LOCATION

There's precautions mark at following position. While using, please follow the content of precaution.

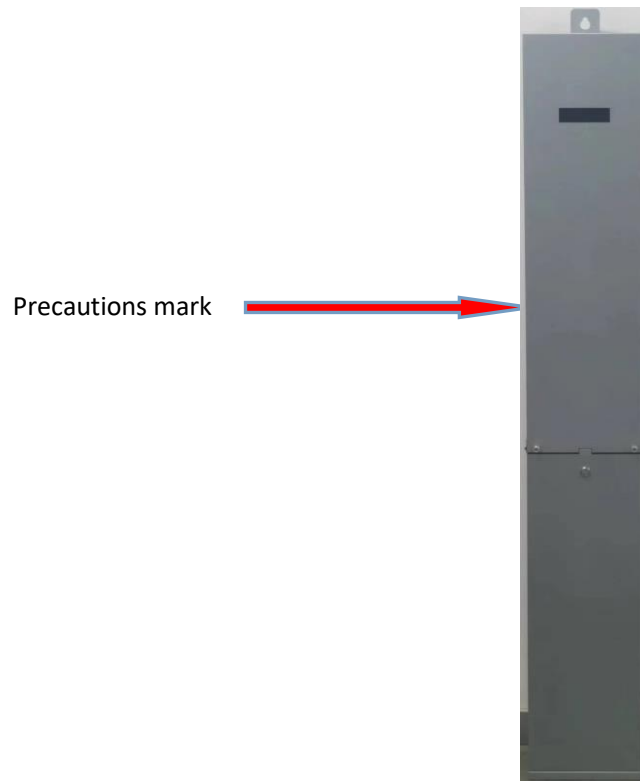

FIGURE 1.1 MRL SAMPLE

The content of precautions are shown as following

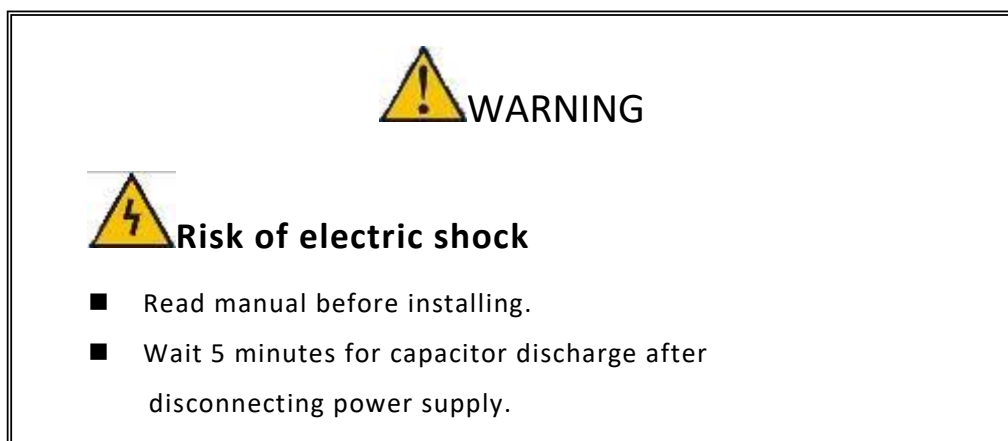

FIGURE 1.2 THE CONTENT OF PRECAUTIONS

## Chapter 2 Introduction and Installation

This chapter introduces models, specifications, product appearance, size, and product function of the V9 series villa lift control cabinet, and describes the checks required upon receiving or installing an Inverter.

### 2.1. System Composition and Model Description

#### 2.1.1 System composition

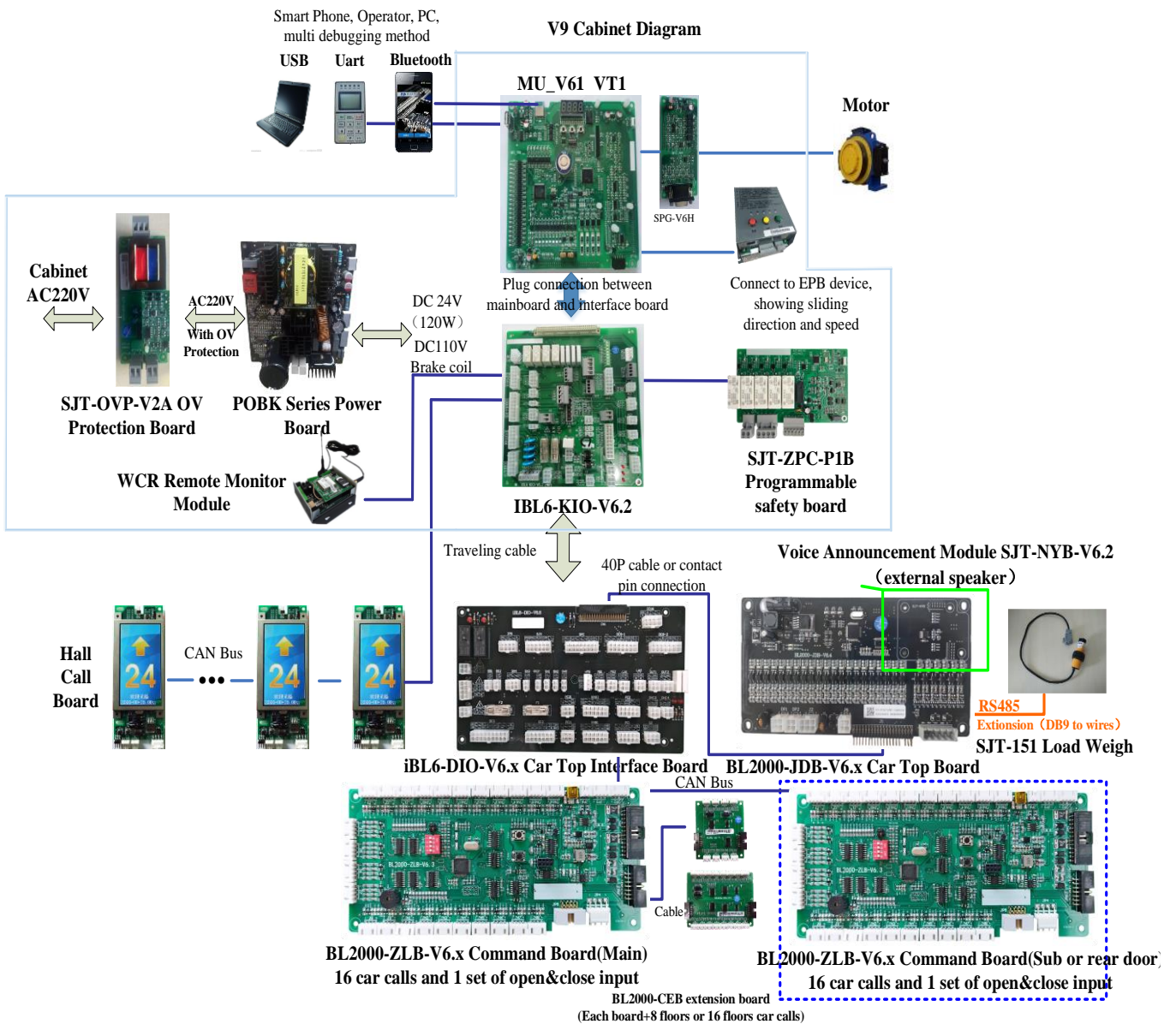

FIGURE 2.1 SYSTEM COMPOSITION OF V9 CONTROL CABINET

### 2.1.2 Model description

The model of V9 series villa lift control cabinet on the nameplate indicates the specification, voltage level, and maximum motor capacity of the controller in alphanumeric codes. Refer to Figure 2.2 for example (5.5kw, 400V rank).

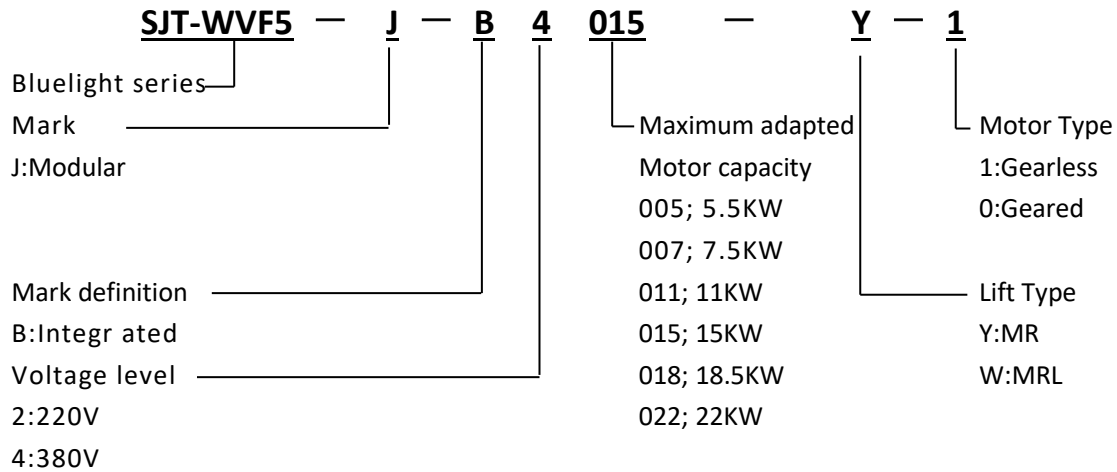

FIGURE 2.2 MODEL DESCRIPTION DIAGRAM

## 2.2. Nameplate Information

Nameplate information is shown in Figure 2.3 below.

Nameplate attached to the right side of V9 series villa lift control cabinet describes the model, power, input, output, serial number, and other information about the controller.

**Example;** A standard nameplate for V9 series villa lift control cabinet; 3-phase, 400 VAC, 2.2KW.

ELEVATOR CONTROL SYSTEM			
Rated Load	450 kg	Rated Speed	0.5 m/s
Rated Voltage	AC220V	Rated Power	2.2kW
TYPE	SJT-WVF5	Rated Current	11A
Layer/ Station	10/10	Control Mode	Full collective
Certificate Institution	Elevator Testing Center of Shanghai Jiaotong University	Speed Control Mode	AC variable frequency speed regulation
Serial No.	EN81-047	Date	2022-12-01

FIGURE 2.3 NAME PLATE INFORMATION

## 2.3. Specifications

Specifications of V9 series villa lift control cabinet in chart 2.1.

Chart 2.1 Specifications

MODEL: SJT-WVF5-J-B40□□		4002	4003	4005	4007	4011	4015	4018	4022
RATED OUTPUT	MAX MOTOR POWER(KW)	2.2	3.7	5.5	7.5	11	15	18.5	22
	RATED OUTPUT CAPACITY(KVA)	4	5.9	9	12	18	22	27	32
	RATED OUTPUT CURRENT(A)	5.5	9	14	18	27	34	41	48
	MAX OUTPUT VOLTAGE(V)	3-PHASE, AC380 (CORRESPONDING TO THE INPUT VOLTAGE)							
	RATED FREQUENCY(Hz)	50							
	MAX OUTPUT FREQUENCY(Hz)	120							
INPUT POWER	RATED VOLTAGE (V)	3-PHASE, AC380							
	RATED FREQUENCY (Hz)	50							
	RATED INPUT CURRENT (A)	10	11	17	22	32	41	49	58
	ALLOWABLE VOLTAGE FLUCTUATION	±15%							
	ALLOWABLE FREQ FLUCTUATION	±5%							
DRIVE FEATURES	ELEVATOR CONTROL MODE	SIMPLEX COLLECTIVE, DUPLEX COLLECTIVE, 3~8 UNITS GROUP CONTROL							
	ELEVATOR SPEED RANGE	0.5~4m/s							
	APPLICABLE HIGHEST FLOOR	64 STOPS							
	APPLICABLE ELEVATOR TYPE	PASSENGER LIFT, RESIDENTIAL LIFT, HOSPITAL LIFT, SIGHTSEEING LIFT, FREIGHT LIFT							
	APPLICABLE MOTOR	GEAR TRACTION MACHINE, GEARLESS TRACTION MACHINE							
	COMMUNICATION MODE	CAN BUS SERIAL COMMUNICATION							
	LEVELING ACCURACY	≤3MM							
CONTROL INPUT/OUTPUT	CONTROL MODE	SPACE VECTOR PWM(SVPWM) CLOSED LOOP VECTOR CONTROL							
	CARRIER FREQUENCY	8KHz (6~15KHz ADJUSTABLE)							
	SPEED CONTROL RANGE	1;1000							
	SPEED CONTROL ACCURACY	±0.05%(25C±10C)							
	SPEED RESPONSE	30Hz							
	TORQUE LIMIT	YES (SET BY PARAMETER)							
	TORQUE ACCURACY	±5%							
	FREQUENCY CONTROL RANGE	0~120Hz							
	FREQUENCY ACCURACY	DIGITAL REF; ±0.01% (-10C ~+40C)							
	FREQUENCY REF RESOLUTION	DIGITAL REF; 0.01Hz							
	OUTPUT FREQ RESOLUTION	0.01Hz							
	OVERLOAD CAPACITY	150% RATED CURRENT 60s;200% RATED CURRENT 10s							
	STARTUP TORQUE	200% RATED CURRENT 0Hz							
ACCEL/DECAL TIME	0.001~600s								

CHART2.1 SPECIFICATIONS (CONT'D)

DRIVE FEATURES	MAIN CONTROL FUNCTION	START WITHOUT LOAD COMPENSATION, BATTERY OPERATION, AUTO TUNING, LOAD COMPENSATION, COOLING FAN CONTROL, BASE BLOCK, TORQUE LIMIT, CAN COMMUNICATION REF, ACCELERATION/ DECELERATION TIME, S CURVE ACCELERATION/ DECELERATION, MONITOR OF MAIN MACHINE FOR WHICH ELECTRIC CURRENT CAN BE EFFECTIVELY INTERDICT OR NOT WHEN THE CAR STOP, INTERNAL BRAKE, PGFREQ DIVIDING OUTPUT, AUTOMATIC FAULT RETRY, AUTOMATIC FAULT RESET, PARAMETER COPY
	CONTROL INPUT/OUTPUT	OC INPUT CONTROL POWER
RELAY OUTPUT POWER		ISOLATED INTERNAL DC24V
LOW OPTO-ISOLATED INPUTS		26-CHANNEL SWITCHES; RATED LOAD; 7MA/DC24V, UPPER FREQ100HZ
PROGRAMMABLE RELAY OUTPUT		13-CHANNEL SWITCHES; 9 CHANNELS; 1NO, CONTACTOR CAPACITY; 5A/30VDC, 5A/250VAC
CAN COMMUNICATION INTERFACE		2CHANNELS; DUPLEX/ GROUP CONTROL, HOP/COP, REMOTE WIRELESS MONITORING
RS-232COMMUNICATION INTERFACE		1CHANNEL; DIGITAL OPERATOR/ PC MONITORING/ PROGRAMMABLE INTERFACE
DISPLAY	DIGITAL OPERATOR	LCD DISPLAY IN CHINESE/ENGLISH
	MONITORING SOFTWARE INTERFACE	DISPLAY PARAMETERS, ELEVATOR RUNNING STATUS, DIGITAL WAVE
MAIN PROTECTION FUNCTION	OVER CURRENT	STOP WHEN CURRENT EXCEED 200% RATED OUTPUT CURRENT
	FUSE	STOP AT FUSE BRAKE AT MAIN CIRCUIT
	OVERLOAD PROTECTION	STOP AT 150% RATED CURRENT 60s/200% RATED CURRENT 10s
	OVERVOLTAGE PROTECTION	STOPS AT DC BUS VOLTAGE OVER 720V (400V DRIVE) OR 410V (200V DRIVE)
	UNDERVOLTAGE PROTECTION	STOPS AT DC BUS VOLTAGE UNDER 380V (400V DRIVE) OR 190V (200V DRIVE)
	HEATSINK OVERHEAT PROTECTION	PROTECT BY THERMISTORS
	IGBT INTERNAL PROTECTION	IGBT OVER CURRENT/ OVERHEAT/ SHORT CIRCUIT/UNDER VOLTAGE PROTECTION
	MOTOR PROTECTION	OVERLOAD PROTECTION STOP
	IMPACT RESTRAINING CIRCUIT	PROTECT BY CONTACTOR FEEDBACK
	OVER SPEED PROTECTION	PROTECT AT SPEED EXCEED THE MAXIMUM ALLOWABLE SETTING
	SPEED DEVIATION PROTECTION	PROTECT AT SPEED DEVIATION EXCEEDS ALLOWABLE VALUE
	PG FAULT PROTECTION	PROTECT AT PG DISCONNECTION/ PHASE ERROR
	AUTO-TUNING PROTECTION	PROTECT AT AUTO-TUNING FAULT.
	OPEN-PHASE PROTECTION	PROTECT AT INPUT/OUTPUT PHASE LOST
	DOOR INTERLOCK FAULT	PROTECT AT DOOR INTERLOCK CIRCUIT OPEN WHEN RUNNING
	SAFETY CIRCUIT FAULT	PROTECT AT SAFETY CIRCUIT OPEN WHEN RUNNING
	BRAKE CIRCUIT FAULT	NO BRAKE OPEN FEEDBACK SIGNAL AFTER OUTPUT BRAKE OPEN COMMAND
	LEVELING ZONE FAULT	PROTECT AT LEVELING ZONE SIGNAL FAULT
	OUTPUT CONTACTOR FAULT	PROTECT AT OUTPUT CONTACTOR FAULT
	RUNNING TIME PROTECTION	PROTECT AT SIGNAL RUNNING TIME EXCEEDS LIMIT
	FLOOR COUNTING FAULT	PROTECT AT FLOOR COUNTER FAULT
	COMMUNICATION INTERFERENCE FAULT	PROTECT AT COMMUNICATION INTERFERENCE FAULT
HOISTWAY PARAMETER LEARNING FAULT	HOISTWAY PARAMETER LEARNING FAULT PROTECTION	

CHART2.1 SPECIFICATIONS (CONT'D)

STRUCTURE	PROTECTION DEGREE	C; CLOSED IP20; O; OPEN IP00
	COOLING	FORCED AIR COOLING
	INSTALLATION	FLOOR MOUNTED, RECESSED OR HANGING INSTALLATION
USING AMBIENCE	AMBIENT TEMPERATURE	-10C~+40C
	HUMIDITY	5~95%RH, NON-CONDENSING
	STORAGE TEMPERATURE	-20C ~+60C
	APPLICATION SITUATION	IN DOORS, WITHOUT DIRECT SUNLIGHT, DUST, CORROSIVE/EXPLOSIVE GASES, OIL FOG, VAPOR, WATER DRIPPING, OR SALTY SUBSTANCES
	ALTITUDE	<1000M
	VIBRATION	10~20Hz, <9.8m/s <sup>2</sup> ; 20~50HZ, <2m/s <sup>2</sup>

### 2.4. Appearance and External Dimension

The outside view and dimension of V9 series modular cabinet is shown in Figure 2.4 and 2.5.

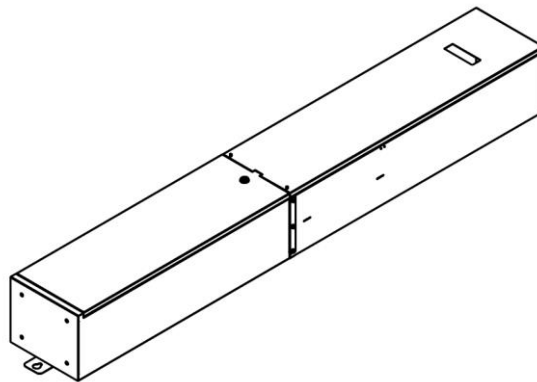

FIGURE 2.4 V9 CABINET OUTSIDE VIEW

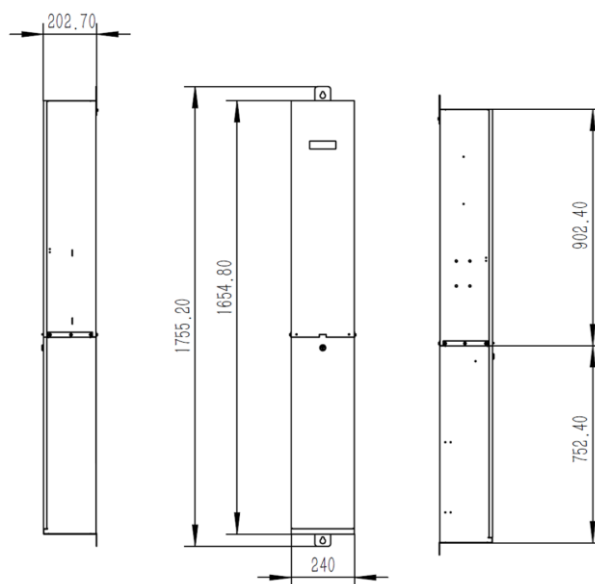

FIGURE 2.5 V9 CABINET DIMENSION (UNIT:mm)

## 2.5. Cabinet Installation Type

V9 series modular cabinet has MR and MRL two installation type. The outside view is shown in Figure 2.6 and 2.7.



FIGURE 2.6 MR CABINET



FIGURE 2.7 MRL CABINET

## 2.6. Confirmation upon Delivery

Check below items when receiving the products.

Chart 2.2 Things to check upon delivery

NOTES	METHOD
Check if product model is correct.	Check the model on the nameplate.
Check if product is broken.	Check exterior for any damage caused by shipment.
Check if mounting structure is loose.	Check mounting structure. Tighten the loose components with a screw driver, if required.
Check if main control board is loose.	Remove the front cover and check mounting structure. Tighten the loose component switch a screw driver, if required.

With any abnormalities above, please contact the company or regional office.

## 2.7. Installation

### 2.7.1 Installation Site

Install V9 series villa lift control cabinet in an area that meets the requirements listed in chart 2.3

Chart 2.3 Installation Environment Requirements

Type	Installation	Ambient Temperature	Ambient Humidity
MRL/MR	Wall-mounted	-10°C~+45°C	5~95%RH (No condensation)

Installation of controller should note the following;

1. Install the controller in a clean location which is free from oil mist and dust, or in a fully closed control cabinet which is completely shielded from floating dust.
2. Install the controller in a place which metal powder, oil, water, and other foreign bodies cannot enter.
3. Do not install the controller in or nearby wood and other combustibles.
4. Install the controller in a place without radioactive substances.
5. Install the controller in a place without harmful gas and liquid.
6. Install the controller in a place without vibration.
7. Install the controller in a place without chlorides.
8. Install the controller in a place without direct sunlight.

### 2.7.2 Temperature Requirement

To enhance the reliability, the controller should be installed in an environment temperature is not easy to rise. When installed in a cabinet, cooling fans or air conditioner are required to keep air temperature in the cabinet below 45°C.

### 2.7.3 Protect the controller from Foreign Object

Place a cover over the controller during installation to shield it from metal powder produced by drilling. Be sure to remove the cover from the controller after the completion of installation. Otherwise, ventilation will be reduced, causing the controller to overheat.

## 2.8. Braking Resistor Configuration

Elevator belongs to potential energy type load. When elevator is under braking status, the motor feedback power will make DC Bus voltage raise up. There must be suitable braking device to release the power. Otherwise it will cause Over-Voltage protection. V9 series modular cabinet has built-in braking unit and just need to adapt suitable braking resistor. According to various motor capacity, the resistance and capacity of resistor will be various

Please check detail in following chart 2.4.

Chart 2.4 Model List of braking resistor

Model	Motor Capacity (kW)	Braking resistance (Ω)			Suggested Capacity (W)	
		Min	Max	Type	Gearless	Geared
400V (Voltage range 85%≤3Φ380V≤120%)						
SJT-WVF5-J-B4002	2.2	90	200	100	600	500
SJT-WVF5-J-B4003	3.7	70	110	80	1100	800
SJT-WVF5-J-B4005	5.5	56	90	75	1600	1200
SJT-WVF5-J-B4007	7.5	46	70	65	2200	1600
SJT-WVF5-J-B4011	11	28	45	40	3500	2500
SJT-WVF5-J-B4015	15	28	35	30	4500	3500
SJT-WVF5-J-B4018	18.5	17	29	25	5500	4500
SJT-WVF5-J-B4022	22	17	24	20	6500	5000

## 2.9. Product Function

Functions list shown in chart 2.5-2.8

Chart 2.5 Basic Function List

No.	Name	Purpose	Description	Note
1	Automatic Run		1. Door auto open at stop; 2. Door auto close in delay time; 3. Door close at close button pushed; 4. Car call register, auto cancel wrong call; 5. Landing call stop car in same direction 6. Car service opposite direction landing call at top/bottom floor	1. Turn all inspection switch to normal state; 2. Turn Auto/Attendant switch to Auto state; 3. The other two Auto/Inspection switch at Auto state;
2	Attendant Run		1. Door auto open at stop; 2. Door close at close button pushed; 3. Car call auto register/ cancel wrong call; 4. Landing call stop car in same direction;	1. Turn all inspection switch to normal state; 2. Turn Auto/Attendant switch to Attendant state; 3. The other two Auto/Inspection switch at Auto state;
3	Inspection Run	Used at System Commissioning; Maintenance	When push up/down button in inspection mode, car runs up/down at inspection speed. Car stop once button released.	Auto/Inspection switch at car top, car and control cabinet, priority from high to low.
4	Auto door open at power on	Auto door open	If car at leveling zone at power on, door open automatically.	
5	Auto door close in delay time	Door keep opening	After door complete opened, it keeps open and will auto close after delay time.	1. Delay time is set through open door holding time parameter (T) 2. T-2s with only landing call 3. T+2s with both landing call and car call.
6	Door OP at current floor landing call	Door open for landing call	If landing call on the same floor at door closing or door closed but car not running, door will open automatically.	Delay time is set by open door holding time.
7	Safety Plate/light curtain	Close door safely	If safety plate touched/light curtain covered, door will open and close again.	Door safety plate/light curtain reset, door automatically close again.
8	Overload door keep open	Wait for load reduction	Door open at overload, with overload light on, buzzer sounds, CZ display on COP. Car not running.	Elevator back to normal state when overload is cleared.

Cart 2.5 Basic Function List (Cont'd)

No.	Name	Purpose	Description	Note
9	Full-load drive by pass	Run to nearest registered floor	At full load, car only respond to car call, not to landing call.	Elevator back to normal state when overload is cleared.
10	Attendant control by pass	VIP Run	At attendant run, press pass over button, elevator only responds to car call.	
11	Operation mode display	Adjust/Maintenance	Elevator Running mode, direction, floor, door mode, load and fault information display on integrated controller LCD.	
12	Auto control light	Energy Saving	Car box light turned off if elevator is not used for 15 minutes. Turned on after receiving any call.	
13	Fire-Service Mode		<p>System enters <b>fire-service mode</b> when fire switch is closed;</p> <ol style="list-style-type: none"> <li>1. Clear up all landing/car call;</li> <li>2. Auto return to fire floor</li> <li>3. Door keep opens</li> <li>4. Output fire linkage signal after return to fire floor.</li> <li>5. If elevator runs in opposite direction, stop at nearest floor, do not open door, run directly to fire floor, door keep opens.</li> </ol>	<p>Two fire-service modes for option;</p> <p><b>Fire mode 1;</b> Elevator stop running after returning to fire floor.</p> <p><b>Fire mode 0;</b></p> <ol style="list-style-type: none"> <li>a) Landing call disabled;</li> <li>b) Door keep opens at fire floor;</li> <li>c) To run elevator, fireman should first choose the target floor, press and hold the <b>close door</b> button till door close, elevator run; if <b>close door</b> button is released before door closed, door open again.</li> <li>d) Arriving target floor, press and hold <b>open door</b> button till door opens, otherwise door close again.</li> <li>e) Can only set one floor every running.</li> </ol>
14	Auto stop at elevator fault	Free passengers	When car stop outside landing zone at elevator fault, it will auto crawl to leveling zone in middle floor direction and open door.	Only if safety circuit and inverter are both working normal.

Cart 2.5 Basic Function List (Cont'd)

No.	Name	Purpose	Description	Note
15	Parking	Stop Running	<p>Elevator enters parking mode at electric lock closed.</p> <ol style="list-style-type: none"> <li>1. Elevator does not respond to landing call, service all car call and return to parking floor (adjustable);</li> <li>2. If no car call, elevator directly return to parking floor;</li> <li>3. After return to parking floor;               <ol style="list-style-type: none"> <li>a. HOP and COP display parking sign "ZT";</li> <li>b. Do not respond to car/landing call;</li> <li>c. After 10s, door close, car box light and HOP/COP display turn off.</li> <li>d. Press any COP/Open, close door button, car box light turns on;</li> <li>e. Press Open/Close door button, car door close again and cut car box light after 10s.</li> </ol> </li> </ol>	<ol style="list-style-type: none"> <li>1. If elevator at inspection mode when close electric lock, car cannot auto return to parking floor. Other functions remain.</li> <li>2. Integrated controller in working state when elevator at parking mode. Once open electric lock, elevator will run normally.</li> </ol>
16	Duplex Control	Two elevator optimized control	<ol style="list-style-type: none"> <li>1. At landing call, both elevator answers based on their running state and location, and only one elevator respond to increase the running frequency.</li> <li>2. When both elevators at waiting state, one return to waiting floor (normally G floor), the other one stays at current location.</li> </ol>	To achieve duplex, connect two integrated controllers with the cable provided and set duplex parameter accordingly.
17	Group Control	Multi-Elevator	Control up to 8 elevators together	

Chart 2.6 Special Function List

No.	Name	Purpose	Description	Note
1	Hoistway Learning	Measure, store hoistway data.	In inspection mode, from bottom terminal switch to top terminal switch, measure and store the landing zone and hoistway switch position.	<p>Hoistway learning may be terminated in unusual condition and system will give error code accordingly. Please follow <b>Chart 8.2</b> for detail error codes.</p> <p>▲ <b>Note:</b> When hoistway learning stops, only when "Success" is displayed on the operator means hoistway learning success.</p>

Chart 2.6 Special Function List (Cont'd)

No.	Name	Purpose	Description	Note
2	Double press Cancellation	Cancel car call	Press car call button again could cancel such call. (Button answer light off)	Such function is also achievable when elevator is not running.
3	Anti-mischief	Cancel car call at terminal	1. When elevator reaches terminal switch, clear all car call. 2. For elevator with weighing device, only last 3 car calls are registered at light load.	
4	Landing call button stuck diagnose	Repair indication	If one landing call button is pressed for more than 20s, it is considered stuck (cannot reset), such call is not registered, button answer light flashes.	Exit such state when button is reset.
5	Repeat close door		At close door command, if door interlock circuit not connected in set time, door open and close again.	If repeat 5 times and door interlock circuit still not close, elevator stops for service, display error code accordingly.
6	Machine room floor selection	Maintenance	Use hand operator to input car call	
7	Machine room floor open/close door	Maintenance	Use hand operator to input open/close door command	
8	Non-Stop Floor		User can set any floor not to stop	
9	Homing floor set	Wait at homing floor	In auto mode, with no landing/car call for certain time, car goes to homing floor.	Can only set one homing floor.
10	Display character set	Change display of certain floor	Display character on any floor can be set through hand operator. (Character or Figure)	
11	Attendant Direction Set	VIP Mode	Choose elevator direction through up/down button before running	Only available in Attendant mode.

Chart 2.6 Special Function List (Cont'd)

No.	Name	Purpose	Description	Note
12	Auto Start/Stop Elevator Service	Automatic start/stop elevator service	User may set elevator on/off time by practical requirement.	<ol style="list-style-type: none"> <li>1. Time is set by 24hrs</li> <li>2. Cancel this function by setting both on/off time to 00.</li> <li>3. This function is only available with electric lock open, otherwise elevator in parking mode.</li> <li>4. To enable elevator service in off time; <ol style="list-style-type: none"> <li>a. Close electric lock, wait for 1s, reopen electric lock to enter <b>force on</b> mode, elevator could use normally.</li> <li>b. Close electric lock after use, wait for 1s, reopen electric lock to exit <b>force on</b> mode, elevator in off time.</li> </ol> </li> </ol>
13	Special Running	Special Passenger Service	Landing call is invalid, elevator controlled by attendant. Door control mode is attendant mode.	Only available with special buttons.
14	Door open time delay set	Delay the door open time	Press this button before car door fully closed, door open time will be delayed to setting time.	<ol style="list-style-type: none"> <li>1. Must have door open delay button</li> <li>2. Only available in Auto Mode</li> <li>3. Normally used in bed elevator system</li> </ol>
15	Rear door control	Elevator with two doors	Control rear door operation on each floor	Follow section 6.8 for rear door mode setting.
16	Trouble Shooting	Automatic find and record fault data.	<ol style="list-style-type: none"> <li>1. When fault happens, system diagnoses fault condition and display error code on LCD.</li> <li>2. System record the last 30 fault data (fault time/class/floor) in error report menu for further reference.</li> </ol>	For trouble shooting error code please follow <b>Chart 8.1</b> Trouble shooting for Elevator
17	Interference evaluation	Inspect site interference condition	Evaluate the site shielding condition, including control cabinet/hoistway connection to ground, help to increase resistance to interference.	This function is only available after elevator commissioning and testing.
18	Encoder Evaluation	Inspect encoder output signal	Analyze the evaluate encoder output signal, help service team onsite maintenance to eliminate elevator shock and leveling issue.	Provide direct evidence on encoder quality and interference condition.
19	Input port evaluation	Inspect input signal interference	System evaluates and displays the input signal quality, help service team to increase the hoistway cable resistance to interference and eliminate elevator COP/HOP display fault information and leveling issue.	Provide direct evidence on input signal interference.

Chart 2.6 Special Function List (Cont'd)

No.	Name	Purpose	Description	Note
20	Emergency Auto Leveling (ARD mode)	After power cut, elevator powered by emergency leveling device, level to nearby landing zone.	<p>After power cut, elevator powered by emergency leveling device and level to nearby landing zone to free the passenger. Such function must meet certain requirements;</p> <ol style="list-style-type: none"> <li>1. After power cut, elevator powered by emergency leveling device. (integrated controller I/O board terminal X18 enable);</li> <li>2. Elevator NOT in inspection mode;</li> <li>3. Elevator NOT at landing zone;</li> <li>4. Elevator can run normally;</li> <li>5. Safety/Door inter-lock circuit close;</li> </ol> <p>Elevator emergency leveling procedures when not at landing zone;</p> <ol style="list-style-type: none"> <li>1. Determine run direction based on load condition (need weighing device);</li> <li>2. After leveling to nearby floor, door keep open, and emergency leveling device cuts off power.</li> <li>3. After power recovery, if system record a history of emergency leveling action, elevator return to bottom floor to re-calibrate hoistway data.</li> </ol> <p><b>When at landing zone</b>, emergency leveling device supply power, elevator door open (integrated controller I/O board terminal X18 must enable).</p>	Because the power of emergency automatic leveling running is supplied by elevator emergency automatic leveling controller device, drawings of controller system is different from standard drawing. When you need this function, please ask technique department for drawings accordingly.
21	Elevator for handicapped	Special COP/HOP for handicapped	<ol style="list-style-type: none"> <li>1.start elevator for handicapped function through parameter setting;</li> <li>2. COP; Car call function &amp; door open/close button.</li> <li>3. HOP; Recognize for handicapped calling through different floor;</li> <li>4. Principle; When leveling, opening time will keep longer if handicapped is on this floor (the opening time can be changed); When press cop opening button, opening time will keep longer.</li> </ol>	<ol style="list-style-type: none"> <li>1.Set HOP address; When use elevator for the handicapped (F4-06-14=ON) , HOP set as below; <b>1~32</b> for normal floor, <b>1</b> for bottom floor, <b>2</b> for second floor, with total 32 floors. <b>33~64</b>for handicapped floor. <b>33</b> for bottom floor, <b>34</b>for second floor, up to<b>64</b>, with total<b>32</b> floors. If building has only one HOP button, keep the other address empty.</li> <li>2.Link Car call button; <b>1~N</b> floor internal select button link to car box<b>1~N</b> floor internal select joint as normal internal select. <b>N+1~N+N</b>as handicapped cop <b>1~N</b> floor internal select. COP Door open 2, Door close 2 input as handicapped door control input (Caution; Elevator for the handicapped cannot use together with rear door function.)</li> </ol>

Chart 2.6 Special Function List (Cont'd)

No.	Name	Purpose	Description	Note
22	Door open in advance	When run at low speed, door open beforehand to improve running efficiency.	Elevator reduce speed when approaching target landing zone, if elevator meets the condition below, door open in advance; 1. Elevator run normally, reaching target landing zone; 2. Two leveling sensors enable; 3. Car speed lower than the set protection speed; 4. Controller low speed output enable; 5. Safety board output enable;	In special function select parameter F4-06-20=ON to enable opening in advance; For opening in advance/re-leveling function principle/wiring diagram please see <b>Appendix 2- opening in advance/re-leveling function description.</b>
23	Re-leveling Function	To achieve re-leveling	Elevator stops at one floor, when passengers move in/out, steel rope will have elastic deformation, and car may move out of landing zone. This function enables elevator to move in low speed back to leveling zone with door open. Condition of re-leveling; 1. Elevator stops and leave landing zone; 2. Two leveling sensors enable; 3. Elevator speed slower than set value; 4. Controller low speed output enable; 5. Safety electric board output enable;	In special function select parameter F4-06-19 to enable re-leveling function; For opening in advance/re-leveling function principle/wiring diagram please see <b>Appendix 2- opening in advance/re-leveling function description.</b>

Chart 2.7 Main safety protection Function

No.	Name	Elevator Description
1	Safety Circuit	Safety circuit open, entire system stops immediately.
2	Door interlock	Elevator can only run with all door interlock closed, otherwise entire system stops immediately.
3	Operation Contactor	System check operation contactor constantly, if found any abnormality, system stop immediately.
4	Brake checking protection	The detection switch of brake arm makes a real-time inspection of opening/closing of the brake. If the brake fails to open as per requirements, the system will prevent the elevator from start.
5	Terminal speed-change&correct floor display	If the elevator detects a terminal switch during running, it will be forced to decelerate and meanwhile automatically correct the floor display.
6	Position-limit protection	If the elevator detects a limit switch, the entire system stops immediately.
7	Limit protection	If the elevator runs to trigger a limit switch, the entire system stops immediately.
8	Instantaneous over-current protection	If detects over 200% rated output current system stops immediately.
9	Fuse blowing protection	When fuse blow, the entire system stops immediately.
10	Overload protection	If detects over 150%/180% rated current, system will stop after 60s/10s.
11	Safety Circuit	Safety circuit open, entire system stops immediately.
12	Door interlock	Elevator can only run with all door interlock closed, otherwise entire system stops immediately.
13	Operation Contactor	System check operation contactor constantly, if found any abnormality, system stop immediately.

Chart 2.7 Main safety protection Function(Cont'd)

No.	Name	Elevator Description
14	Brake checking protection	The detection switch of brake arm makes a real-time inspection of opening/closing of the brake. If the brake fails to open as per requirements, the system will prevent the elevator from start.
15	Terminal speed-change&correct floor display	If the elevator detects a terminal switch during running, it will be forced to decelerate and meanwhile automatically correct the floor display.
16	Position-limit protection	If the elevator detects a limit switch, the entire system stops immediately.
17	Limit protection	If the elevator runs to trigger a limit switch, the entire system stops immediately.
18	Instantaneous over-current protection	If detects over 200% rated output current system stops immediately.
19	Fuse blowing protection	When fuse blow, the entire system stops immediately.
20	Overload protection	If detects over 150%/180% rated current, system will stop after 60s/10s.
21	Over-voltage protection	Main DC bus voltage higher than 780V, system(400V) will stop or main DC bus voltage higher than 410V, system(200V) will stop
22	Under-voltage protection	Main DC bus voltage lower than 380V, system(400V) stop or main DC bus voltage lower than 190V, system(200V) will stop.
23	Radiator overheated protection	Thermal resistor protection.
24	IGBT interior protection	IGBT over current、overheated、short circuit、under-voltage protection.
25	Electric motor protection	Electric thermal protection.
26	Impact restrain loop failure protection	Through contactor joint to feedback protection.
27	Over speed protection	Protect when the speed is faster than allowed.
28	Over deviation protection	Protect when speed deviation is larger than allowed.
29	PG fault protection	Protect when PG braking or phase stagger.
30	Self-study protection	Protect when self-study of motor parameter unusual.
31	Phase lack protection	Protect when lack of in/output phase.
32	Door drive signal	Protect when door signal unusual.
33	Running time protection	Protect when once run time is longer than limited time.
34	Counter of floor protection	Protect when floor counter is wrong.
35	Trouble of communication immunity	Protect when communicate interrupt.
36	Hoistway learning error	Protect when have trouble in hoistway learning.

Chart 2.8 Optional Function List

No.	Name	Elevator Description
1	Remote Monitoring	Monitor elevator running status in monitor current through wire/wireless network.
2	Arrival Gong	Clock announce.
3	Voice Synthesizer	Voice announce.
4	Identity Control	ID/IC Car control.
5	Weighing device	Weighing device for elevator.

## Chapter 3 Wiring

This chapter describes the terminals and wiring specifications for main circuit, control circuit and PG card of the integrated controller.

### 3.1. Elevator Integrated Controller Terminal Wiring Diagram

The wiring of integrated controller in modular cabinet is shown in figure 3.1

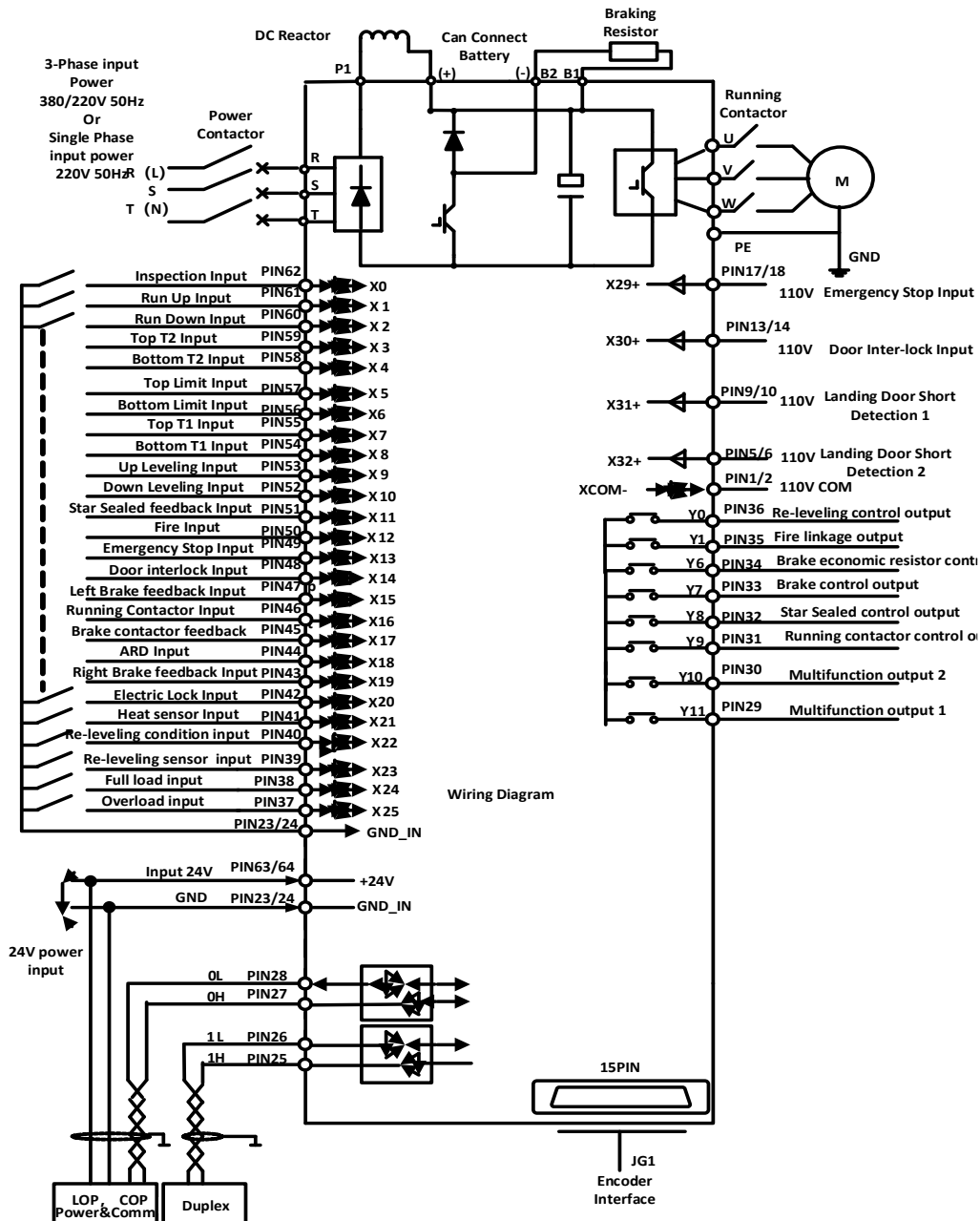

Figure 3.1 Terminal wiring Diagram for Elevator integrated controller

Note; 1. The only external plug is JTR1. The descriptions PINXX (means pin XX) all refer to JTR1 Plug.

2. The definition of X5/X6/X19/X21/X24/X25 are multiplex. The details are in chart 3.2.

### 3.2. Wiring Main circuit Terminals

#### 3.2.1 Main circuit structure

The main circuit wiring in shown in figure 3.2

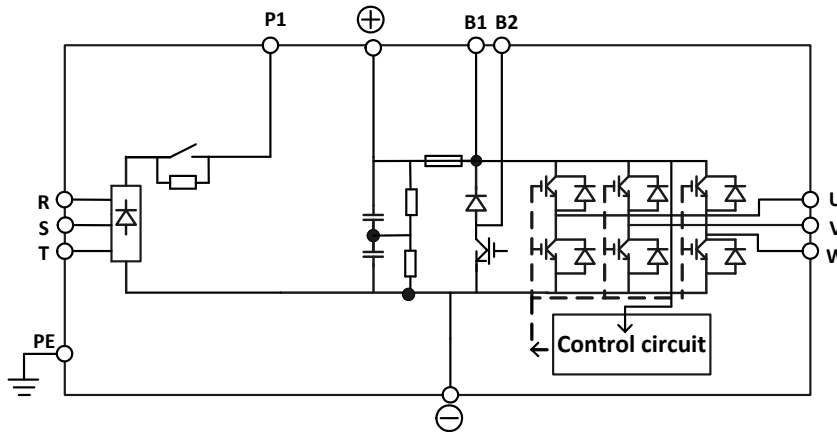

Figure 3.2 Main circuit Structure

#### 3.2.2 Terminal arrangements for Main circuit

The main circuit terminals are shown in figure 3.3.

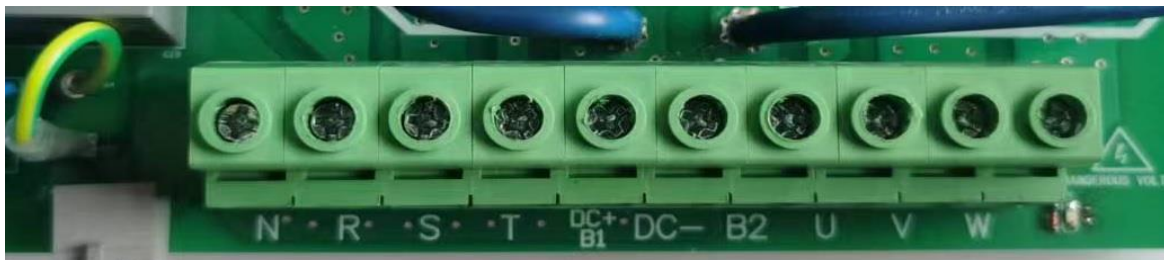

Figure 3.3 Terminal arrangements for main circuit

#### 3.2.3 Main circuit terminal summary and function instruction

The terminal definition and function description are shown in chart 3.1.

Chart 3.1 Main circuit terminal definition & function

Terminal Symbol	Function Instruction
R, S, T,N	Main circuit power 3 phase 4 lines input (380V/220V/50Hz, 3 $\phi$ )
DC+/B1	DC BUS output +/ External Braking resistor terminal connection 1
DC-	DC BUS output -
B2	External Braking resistor terminal connection 2
U, V, W	Controller output terminal, connect with motor

J4 definition and function description are shown in chart 3.2.

Chart 3.2 J4 terminal definition and function description

Terminal Symbol	Function Instruction
J4-1	AC power R after high-frequency capacitor filter.
J4-2	AC power N

Note: J4 terminal is main circuit input power output after high-frequency capacitor filter. This power is supplied to brake power board.

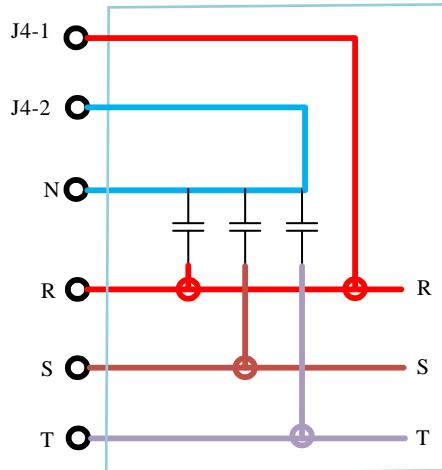

Figure 3.4 Main circuit terminal and J4 terminal.

### 3.2.4 Specifications for main circuit wiring

Chart 3.3 Main Circuit Wires Specification and fastening torque

Controller Model	Terminal Screw	Fastening torque N•m	Available wire mm <sup>2</sup>	Suggested mm <sup>2</sup>
SJT-WVF5-J-B4002	M4	1.2~1.5	4	4
SJT-WVF5-J-B4003	M4	1.2~1.5	4	4
SJT-WVF5-J-B4005	M6	4~5	6~10	6
SJT-WVF5-J-B4007	M6	4~5	6~10	6
SJT-WVF5-J-B4011	M6	4~5	6~10	6
SJT-WVF5-J-B4015	M6	4~5	6~10	6
SJT-WVF5-J-B4018	M6	4~5	8~10	10
SJT-WVF5-J-B4022	M6	4~5	10~16	10

### 3.2.5 Main circuit wiring

#### 3.2.5.1 Wiring main circuit input

When wiring the main circuit, please pay attention to the following matters.

##### 1. Main Circuit Breaker (MCCB) Installing

Connect the power input terminals (R, S, T) and power supply via a main circuit breaker (MCCB) suitable for the controller. The capacity of MCCB should be about 1.8 to 2 times of the controller's rated current. For MCCB's timing characteristics, be sure to consider the controller's overload protection (60s at 150% of the rated output current, 10s at 180% of the rated output current).

## 2. Residual Current Circuit-breaker Installing

As the Controller outputs switch frequently, high-frequency leakage current is generated. A residual current circuit breaker should be applied to the controller input side to eliminate high-frequency leakage current which is harmful to human body. Choosing a special-purpose residual current circuit breaker, its current sensitivity should be up to 30mA or more per controller. When using a general-purpose residual current circuit breaker, its current sensitivity should be upto 200mA or more per controller and with an operating time of 0.1s or more.

## 3. Magnetic Contactor Installing

Power input terminals (R, S, T) can be connected or disconnect to the power supply through a magnetic contactor (KMC). Magnetic contactor capacity depends on the rated current of the controller. Ensure that the capacity of magnetic contactor is greater than the rated current of the controller.

## 4. Terminals Wiring

If there are no phase sequence requirements, the input power supply can be connected with any one terminal (R, S, T) the phase sequence of input power supply does not necessary correspond to the terminal sequence.

## 5. Installing Surge Absorber

Ensure using a surge absorber for each inductive load (including magnetic contactor, electromagnetic relays and magnetic brakes, and so on) near the controller. Inductive loads.

### 3.2.5.2 Wiring the output side of main circuit

#### 1. Connect the controller to Motor

Please connect the motor(input) wires to the output terminals U, V, W. Check that the motor rotates anticlockwise with the forward run command while running, otherwise, exchange the output terminal V and W.

#### 2. Never connect a power supply to output terminals

Never connect a power supply to output terminals U, V, W. If voltage is applied to the output terminals, the controller internal circuit will be damaged.

#### 3. Never short or GND output terminals

Do not allow the output terminals ground or short; Do not allow the output line short circuit or contact controller shell; Do not touch the controller with bare hands. Otherwise, there will be a risk of electric shock or short circuit.

#### 4. Never use capacity, surge absorber, power factor regulator and noise filter.

Never connect capacity, surge absorber, power factor regulator and noise filter to output circuit. The high-frequency components of the controller output may result in overheating or damage to these parts or may result in damage to the controller

#### 5. Use of magnetic contactor

Don't connect a magnetic contactor between the controller and the motor and turn it ON or OFF during operation. Otherwise, a large inrush current will be created and the overcurrent protection in the controller will operate. Before shutting off the contactor, please stop the controller output first, after a while delay, then shut off.

### 3.2.5.3 WIRING EARTH TERMINALS

1. Ensure that earth protection terminal PE connects to ground (Grounding resistance less than 10Ω).
2. Do not share the GND with other devices such as welding machines or power tools.

3. GND wire should be as short as possible and should be as thick as possible.
4. Connect to earth at one point.

#### 3.2.5.4 CONNECT BRAKE RESISTOR

1. There is an internal brake unit in the controller but must equip an external resistor to absorb the feedback energy during brake. Refer to **chart 2.8** for the configurations of the brake resistance.
2. Connect brake resistor to terminal B1, B2.
3. It is recommended to apply heatproof wire with appropriate specification and minimum length to connect brake resistor.
4. The installation of the braking resistor should consider the need of cooling. If necessary, Fans and protection cover can be applied to ensure ventilation and away from burn, electric shock and fire.
5. Do not touch terminals B1 and B2 with bare hands.

### 3.3. Control Circuit Wiring

#### 3.3.1. Control Circuit Terminal location

The control circuit terminal locations are shown in figure 3.5.

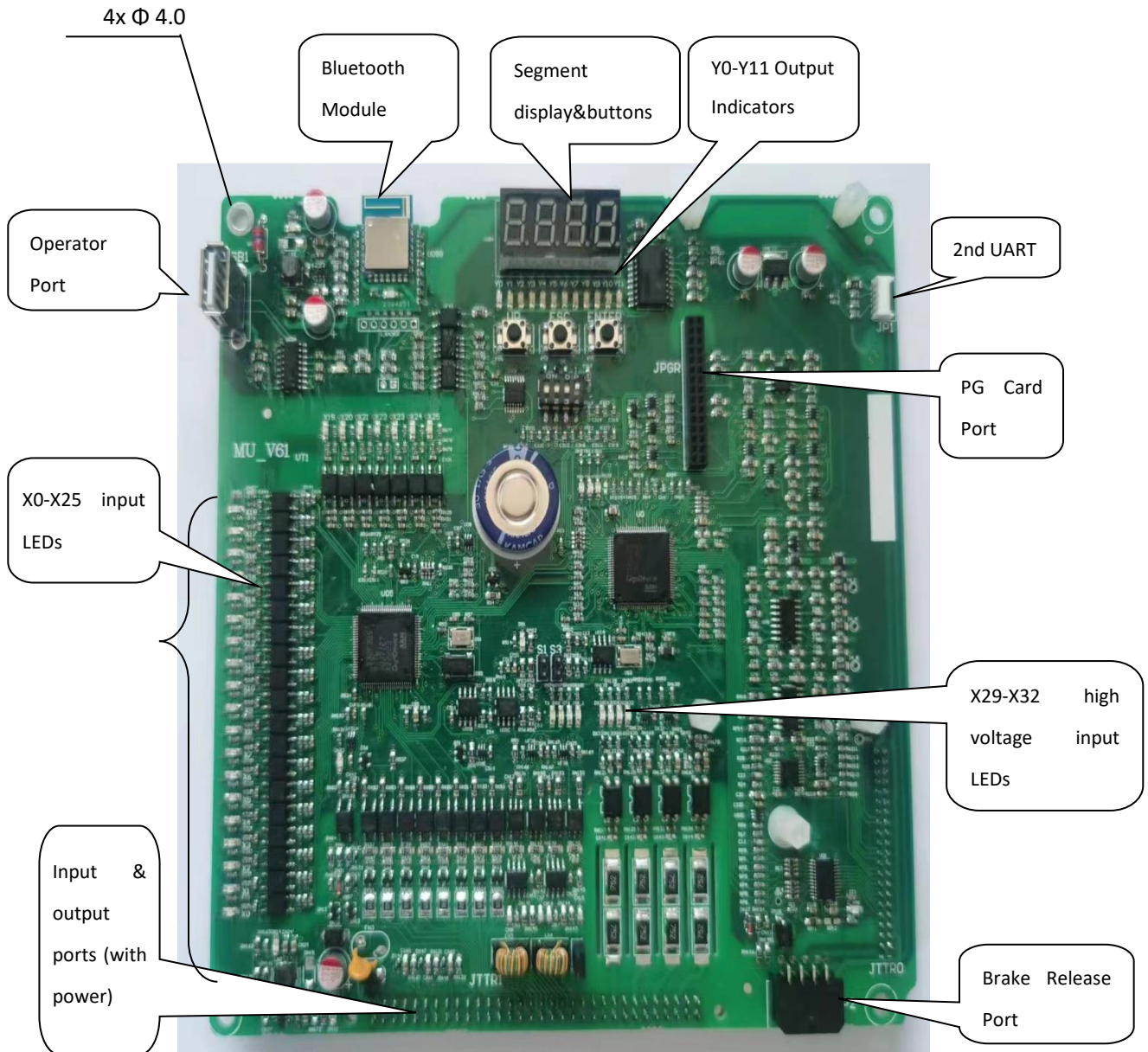

Figure 3.5 Control circuit terminal location

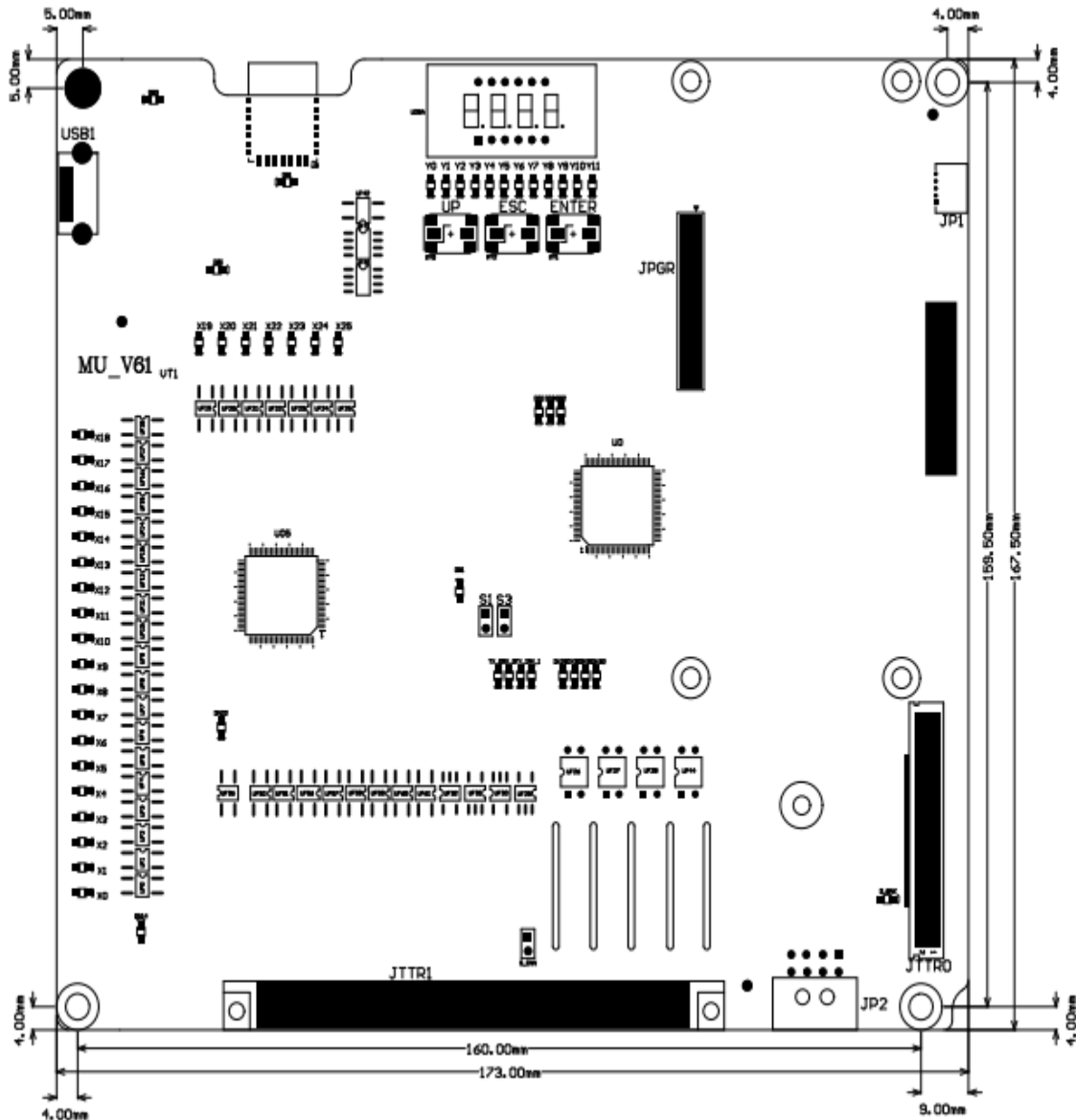

Figure 3.5 Mainboard Dimension

Control circuit includes modular mainboard, PG card and digital operator, and etc. PG card and digital operator will be introduced later.

Because the various range of elevator floor, controller input, output, CAN Bus should be isolated with controller inner part, I/O port need external 24V DC supply. Besides power supply to I/O port, this power will also be used for COP and LOP boards. So the capacity of this power should be chosen according floor conditions.

### 3.3.2. Control Circuit Terminal Connection

The control circuit terminal connection is shown in 3.1.

### 3.3.3. Control Circuit terminal definition and function description

The control circuit terminal definition and function description is shown in Chart 3.4

Chart 3.4 Control Circuit terminal definition and function description

Name	Label	Pin	Definition	Usage	Specification			
					Type	Capacity	OFF/ON Time	Frequency
JTTR1	XCOM-	PIN-1	X29\X30\X31\X32 high voltage input com	Safety Circuit	Opto-coupler	AC110V 20mA	10ms	100Hz
		PIN-2						
		PIN-3	Null					
		PIN-4	Null					
	X32+	PIN-5	Hall/Car door short detection input 2	Safety Circuit	Opto-coupler	AC110V 20mA	10ms	100Hz
		PIN-6						
		PIN-7	Null					
		PIN-8	Null					
	X31+	PIN-9	Hall/Car door short detection input 1	Safety Circuit	Opto-coupler	AC110V 20mA	10ms	100Hz
		PIN-10						
		PIN-11	Null					
		PIN-12	Null					
	X30+	PIN-13	Door interlock input	Safety Circuit	Opto-coupler	AC110V 20mA	10ms	100Hz
		PIN-14						
		PIN-15	Null					
		PIN-16	Null					
	X29+	PIN-17	Safety circuit input	Safety Circuit	Opto-coupler	AC110V 20mA	10ms	100Hz
		PIN-18						
		PIN-19	Null					
		PIN-20	Null					
		PIN-21	Null					
		PIN-22	Null					
	GND_M	PIN-23	0V	Power	Power GND	DC24V10A		
		PIN-24						
	CAN1_H	PIN-25	Duplex/Group communication +	Communication	CAN	80mA		25KH
	CAN1_L	PIN-26	Duplex/Group communication -					
	CAN0_H	PIN-27	LOP/COP communication+					
	CAN0_L	PIN-28	LOP/COP communication -					
	Y11	PIN-29	*Spared output 1		Relay	DC 10A30V AC 10A250V	5/10ms	20cpm
	Y10	PIN-30	* Spared output 2					
	Y9	PIN-31	Running contactor output					
	Y8	PIN-32	Star-sealed contactor output					
	Y7	PIN-33	Brake contactor output					
	Y6	PIN-34	Economic resistor contactor output					
	Y1	PIN-35	Fire linkage output					
	Y0	PIN-36	Re-leveling output					

Chart 3.4 Control Circuit terminal definition and function description (con't)

Name	Label	Pin	Definition	Usage	Specification			
					Type	Capacity	OFF/ON Time	Frequency
JTTR1	X25	PIN-37	Overload input/spared input	Low voltage input signals	Opto-coupler	DC24V 7mA	10ms	100Hz
	X24	PIN-38	Full load input/spared input/UCMP input for geared					
	X23	PIN-39	Re-leveling sensor input					
	X22	PIN-40	Re-leveling feedback input					
	X21	PIN-41	Overheat input/earthquake input					
	X20	PIN-42	Parking input					
	X19	PIN-43	Light load/spared/right brake feedback input					
	X18	PIN-44	ARD input					
	X17	PIN-45	Brake contactor feedback					
	X16	PIN-46	Running contactor feedback					
	X15	PIN-47	Left brake feedback					
	X14	PIN-48	Door contactor feedback					
	X13	PIN-49	Safety contactor feedback					
	X12	PIN-50	Fire input					
	X11	PIN-51	Star-sealed contactor feedback					
	X10	PIN-52	Down re-leveling input					
	X9	PIN-53	Up re-leveling input					
	X8	PIN-54	Bottom slowdown 1					
	X7	PIN-55	Top slowdown 1					
	X6	PIN-56	Bottom limit/Door Bypass input					
X5	PIN-57	Top limit/spared/maintenance mode input						
X4	PIN-58	Bottom slowdown 2						
119-X3	PIN-59	Top slowdown 2						
MX-X2	PIN-60	Inspection Down input						
MS-X1	PIN-61	Inspection Up input						
X0	PIN-62	Inspection input						
+24V	PIN-63 PIN-64	+24V input power	Power	Power	DC24V10A			

Note; 1. DIP Switch definition; Normally, all 4 DIP switches should be OFF, other status are all reserved for factory.

2. While hall door and car door need to be detected seperatedly, detail in Appendix 8.

3. Details of Multi-function output 1 (Y11) and multi-function output 2 (Y10) are in 5.4.5, the description for F3-09 and F3-08.

Besides above terminals, there're other debugging ports on mainboard:

Chart 3.5 Port definition and function description

No.	Port	Function	Type	Note
1	USB1	Digital Operator	RS232	Communication with OP_VX
2	JP1	Watch dog port	RS233	Communication with watch dog.
3	JP2	EPB port		Communication with EPB and get power
4	JPGR	PG card port		Connect with PG_V6, PG_V6X, SPG_V6
5	JTTR0	Bottom drive part port		Connect with bottom drive board
6	U08B	Bluetooth Module	Wireless	On board Bluetooth communication module

### 3.3.4. Control Circuit terminal wire specification

600V plastic insulated wire should be used. Choose appropriate wire model based on terminal function and Refer to Chart 3.4.

Chart 3.4 Wire size for Control circuit terminals

Terminal Function	Acceptable Wire size (mm <sup>2</sup> )	Recommended wire size (mm <sup>2</sup> )	Clamping Torque N.m	Special Requirement
Input/Output	0.5~1	0.75	0.5~0.6	
PG Car I/O	0.15~0.5	0.3	0.5~0.6	Twisted pair shield
CAN COMM	0.75~1.5	0.75 (≤10 floors) 1.5 (>10 floors)	0.5~0.6	Twisted pair shield

### 3.3.5. Control Circuit I/O interface and wiring

#### 3.3.5.1. Digital value Input Interface

The common terminal of board for digital value input interface is +24V, so it should be contactor input or common emitter input (0V common terminal) as shown in Figure 3.6 and Figure 3.7.

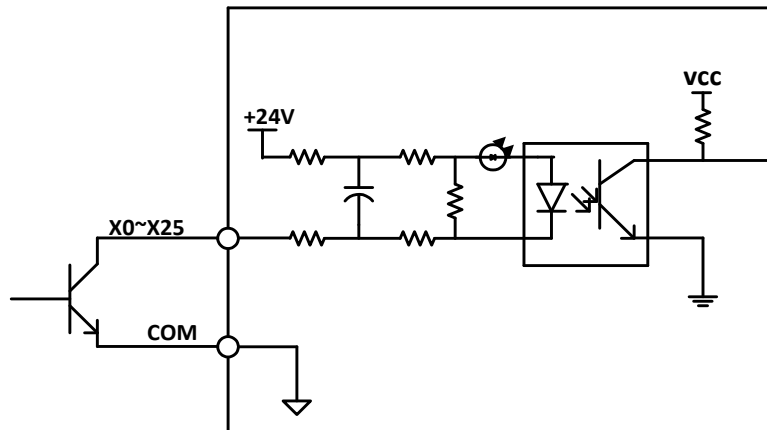

FIGURE 3.6 COMMON EMITTER INPUT

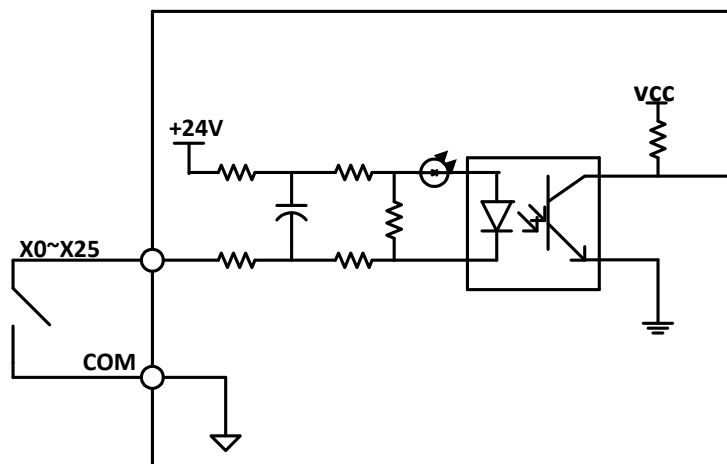

FIGURE 3.7 CONTACTOR SWITCH INPUT

### 3.3.5.2. CAN COMM INTERFACE

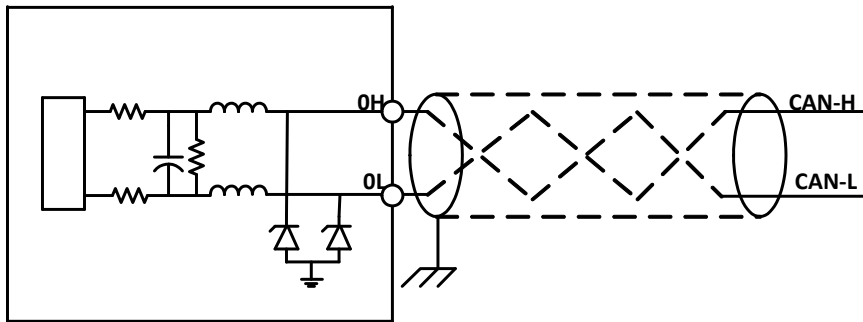

FIGURE 3.8 CAN COMM INTERFACE AND CONNECTION

The controller, COP and HOP are connected through CAN bus. The reliability of CAN BUS communication is directly related to cable wiring. It is specifically required that shaft cable and traveling cable should be **twisted-pair shield cable**.

The twisted-pair can stop the differential mode interference of the long wire while shield can isolate the electromagnetic interference caused during elevator running. The function and connection of the CAN communication interface is shown in the Figure 3.8.

### 3.3.5.3. AC 100V INPUT INTERFACE

AC 110V input interface is for testing of Emergency stop/Door Drive. Its interface/connection is shown in Figure 3.9.

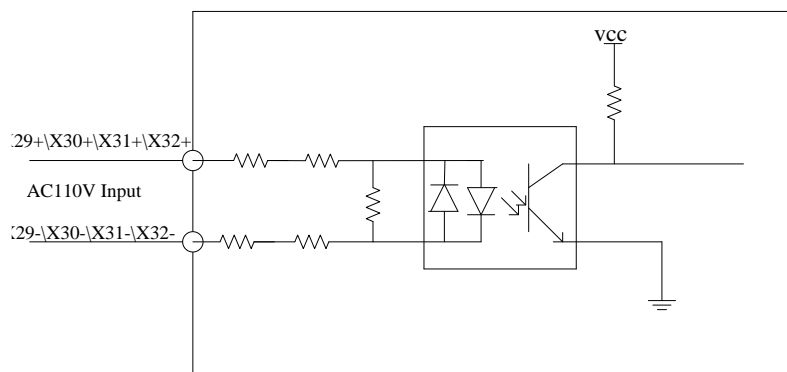

FIGURE 3.9 AC110V INPUT INTERFACE & CONNECTION

### 3.3.5.4. POWER SUPPLY INPUT INTERFACE

Power supply interface and connections are shown in Figure.3.10.

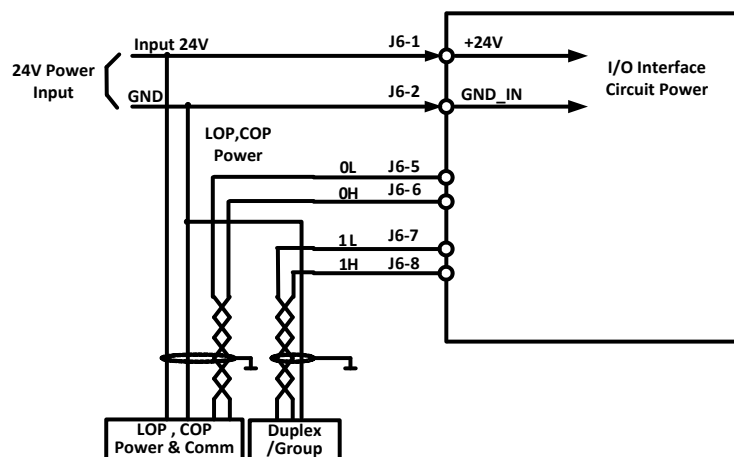

FIGURE 3.10 POWER SUPPLY INTERFACE & CONNECTIONS

### 3.4. PG Card Installation & Wiring (SPG\_V6H )

#### 3.4.1 SPG\_V6 Interface card diagram

SPG\_V6H interface card is sync machine universal sine cosine encoder speed feedback and frequency dividing output card.SPG\_V6 is in supporting use of 5V line driver output type sine cosine encoder. Encoder for sync machine; A/B/R/C/D. (Suitable for ERN1387 encoder and other compatible sin/cos encoder)

SPG\_V6H interface card is shown in figure 3.11. (unit;mm)

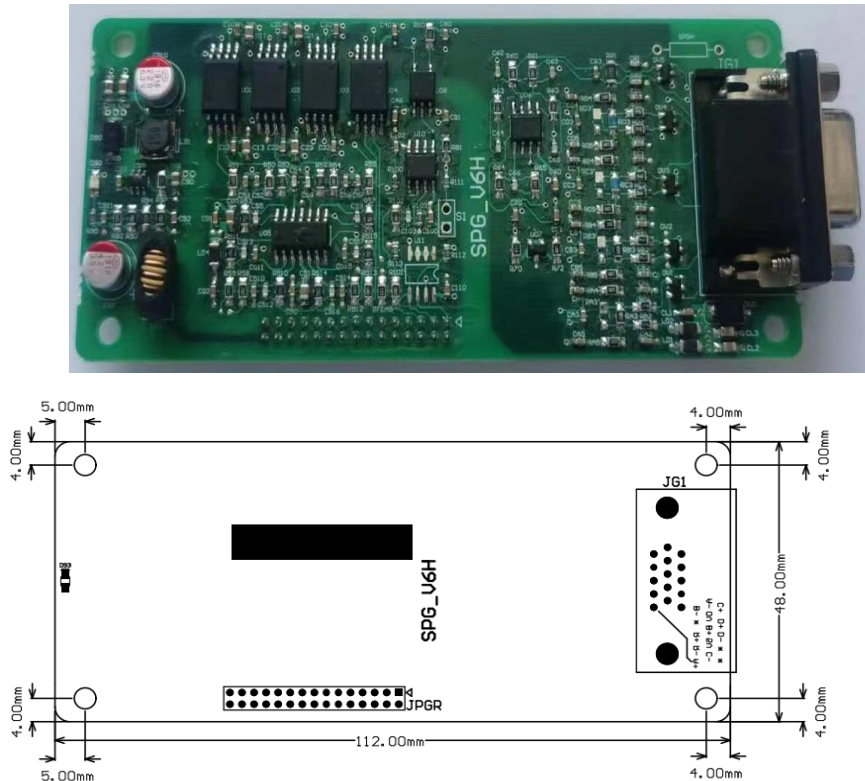

Figure 3.11 SPG\_V6H card appearance and dimension

#### 3.4.2 SPG\_V6H Interface Card Terminal Definition and Function List

SPG\_V6H interface card terminal definition and function are listed in chart 3.5.

Chart 3.5 SPG\_V6H interface card terminal definition and functions

Terminal Name	Terminal Mark	Location	Definition	Usage	Interface Technical Specification			
					Interface Type	Rated Capacity	On/Off Time	Max Speed
JG1	B-	JG1-1	B-	Differential signal B-	D-input	—	—	40KHz
	*	JG1-2	—	--	--	—	—	—
	R+	JG1-3	R+	Differential signal R+	D-input	—	—	40KHz
	R-	JG1-4	R-	Differential signal R-	D-input	—	—	40KHz
	A+	JG1-5	A+	Differential signal A+	D-input	—	—	40KHz
	A-	JG1-6	A-	Differential signal A-	D-input	—	—	40KHz
	0V	JG1-7	GND	5V Ground	PGND	—	—	—

Chart 3.5 SPG\_V6H interface card terminal definition and functions (cont')

Terminal Name	Terminal Mark	Location	Definition	Usage	Interface Technical Specification			
					Interface Type	Rated Capacity	On/Off Time	Max Speed
JG1	B+	JG1-8	B+	Differential signal B+	D-input	—	—	40KHz
	5V	JG1-9	+5V	5Vpower	Power output	+500mA/5V±2.5% Voltage ripple<50mV	—	—
	C-	JG1-10	C-	Differential signal C-	D-input	—	—	40KHz
	C+	JG1-11	C+	Differential signal C+	D-input	—	—	40KHz
	D+	JG1-12	D+	Differential signal D+	D-input	—	—	40KHz
	D-	JG1-13	D-	Differential signal D-	D-input	—	—	40KHz
	*	JG1-14	—	—	—	—	—	—
	*	JG1-15	—	—	—	—	—	—

### 3.4.3 Precautions for using SPG\_V6H

- 1) Sine/cosine PG card can provide power output of  $5V \pm 2.5\%$ /500mA for encoder. If the current required exceeds the PG card rated value, it may damage the PG card or encoder.
- 2) The cut-off frequency of the analog input signal is requested to be lower than 40KHz. This is decided by filter circuit. If the input signal bandwidth exceeds this range, PG card cannot guarantee to analyze the signal correctly and the driver may not work properly.

## 3.5. Precautions with Wiring

1. Before connection, please pay attention to the precautions mentioned in chapter 1.2, especially the “warning” and “caution” part.
2. Before connection, make sure that the power supply is off, and the charge indicator LED is out.
3. Please ask professional engineers with training and authorization for the wiring.
4. The wire size and clamping torque should follow the regulation of Chart 3.2 and chart 3.4
5. To increase wiring convenience and reliability, it is better to use round crimp type terminal (for main circuit) and club-shaped terminal (for control circuit).
6. Wire the control circuit/main circuit/power supply separately.
7. CAN communication cable、encoder cable、encoder frequency output cable and analog input cable should use TWISTED-PAIR SHIELD CABLE.
8. Please ground the cable shield wire correctly and maximize the contact area.
9. Make sure the signal cable for PG/encoder is less than 30m in length, and as short as possible.
10. Make sure the cable between controller and machine is less than 100m, and as short as possible.
11. Make sure the brake resistor is connected between B1 and B2.
12. Make sure the connection of ground terminal PE is secure, do not share the ground cable with other devices such as welding machines or power tools. Minimize length and dimension of ground cable and ground at one point.
13. After wiring, make sure check the following;
  - 1) Correctness and reliability of connection.
  - 2) Whether there is leftover, such as wire, screw and metal filing.
  - 3) Whether the connection of the screw, the terminals and the connection parts are loose.
  - 4) Whether the bare conductor of terminals is connected with other terminals.

## Chapter 4 Digital Operator

V9 series villa lift control cabinet is equipped with LCD digital operator OP-V6. It is a tool for commissioning and maintenance of control system. It provides a nice and easy human-machine interface with both Chinese and English on display.

### 4.1. Key, display and function of Digital Operator

The digital operator OP-V6 has the main LCD screen with resolution of 128×64 LCD, 5 LED and 11 function buttons. Refer to Figure 4.1 below for detail.



FIGURE 4.1 DIGITAL OPERATOR

#### 4.1.1 Operator LED Display











LEDs on the top of the operator display controller current state simply and directly. The definition and display function of each LED, as shown in chart 4.1.

Chart 4.1 LED definition & display function

Name	Function
DRV	When the controller is in operation, the led light.
FWD	When the controller is in forward running operation, the led light.
REV	When the controller is in reversal running operation, the led light.
COM	When the controller communication is normal, the led light.
ERR	When the controller is in fault, the led light.

## 4.1.2 Operator Keys

Chart 4.2 Operator Keys names and functions

Keys	Name	Function Description
	[RUN] Key	Run the controller in keypad control mode; button is disabled in program control mode. Enable/disable is set through parameters.
	[STOP] Key	Stop the controller in keypad control mode; button is disabled in program control mode. Enable/disable is set through parameters.
	[MENU] Key	Return to main menu on any screen.
	[SHIFT] key	Enable the 2 <sup>nd</sup> function of other keys.
	[RESET] Key	Enter the digit setting option for certain parameters.
	[UP] Key	Scroll up menu options or edit figures in certain setting page.
	[DOWN] Key	Scroll down menu options or edit figures in certain setting page.
	[LEFT] Key	For parameter setting, choose the left digit for editing.
	[RIGHT] Key	For parameter setting, choose the right digit for editing.
	[ENTER] Key	Enter the next level sub-menu on main screen; Input set value on parameter setting; Give command; Check fault/warning information.
	[ESC] Key	Return the previous level menu.

### 4.1.3 LCD Display

Controller enters the main interface after power on. The main interface is shown in Figure 4.2.

The main interface displays the main information of the elevator in present status, including floor number, elevator speed, running direction, door lock status, running model, fault code and else. On the main interface, the above information is live updated.

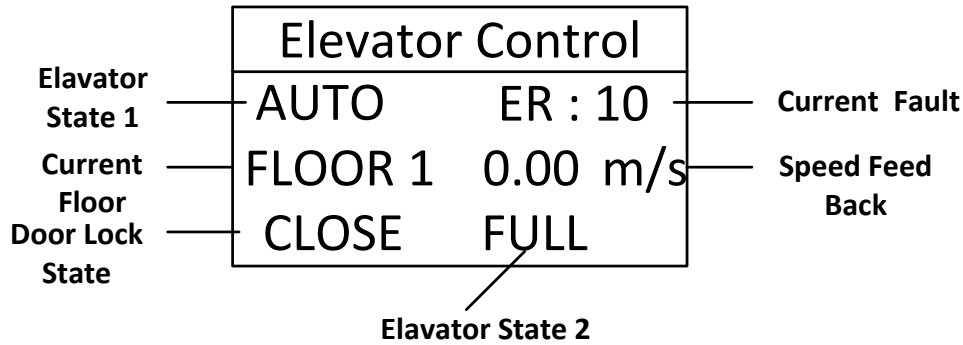

FIGURE 4.2 MAIN INTERFACE ON DIGITAL OPERATOR

The instructions for the information shown in the Digital operator LCD display interface are as following;

1. The status of the elevator display1:

INSP	ARD	MANU	AUTO
FIRE	STOP	USER	

2. Present floor display;

Display the floor number that the elevator is at.

3. Door lock status;

CLOSE/OPEN; Door inter-lock circuit closed/opened.

4. The status of the elevator displays 2;

FULL;	Full load
OVER;	Overload
GROUP;	Group control
TWINS;	Duplex control

5. Present error;

ERR:XX     Display the present Error code.

### 4.1.4 Function of Operator

The function of digital operator is as follows;

1. LCD display with English and Chinese

2. Setting log in level and corresponded password.
3. Adjusting the settings of quick menu
4. Monitor the status of the elevator and the controller.
5. Parameter check, setting and save.
6. Hoistway learning
7. Motor parameter learning
8. Weighing data learning
9. System clock setting
10. Error history log record and check.
11. Parameter copy, upload and download.
12. Restore to factory setting.

#### 4.1.5 Installation and Connection of Digital Operation

The connection for the digital operator of the opening controller is as follows; remove the front cover of the controller, connect one side of the special communication cable to digital operator, and connect the other side to the J232\_T connection on the main board. Make sure the connection is securely; install the front cover of the controller.



IMPORTANT

- 1. The installation, dismantle, insert and remove of the digital operator can be carried out when the controller is power-on. That is to say, hot plug is accepted by the digital controller.**
- 2. Please install, dismantle, insert and remove the digital operator carefully to avoid unwanted damage of the digital operator.**
- 3. Please save the removed digital operator and communication cable well, DO NOT press, damage the operator or put it in extreme environment.**
- 4. Please DO NOT use the self-made (> 3m) communication cable.**

## 4.2. Structure and Switch process of the Operator Interface

The structure and interface switch process of the digital operator, as shown in Figure 4.3.

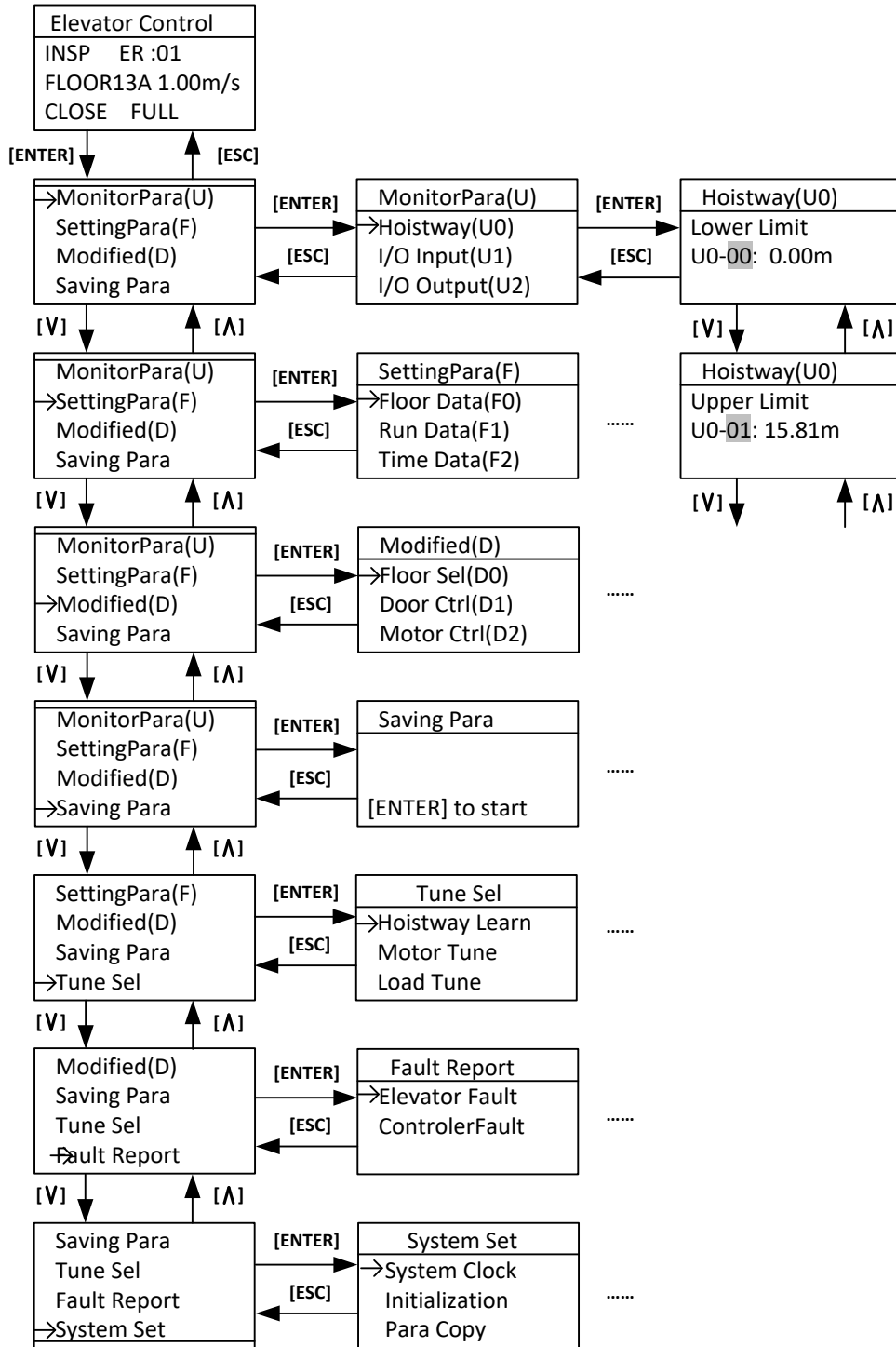

FIGURE 4.3 STRUCTURE FLOWCHART OF OPERATOR MENU

### 4.3. Parameter Setting

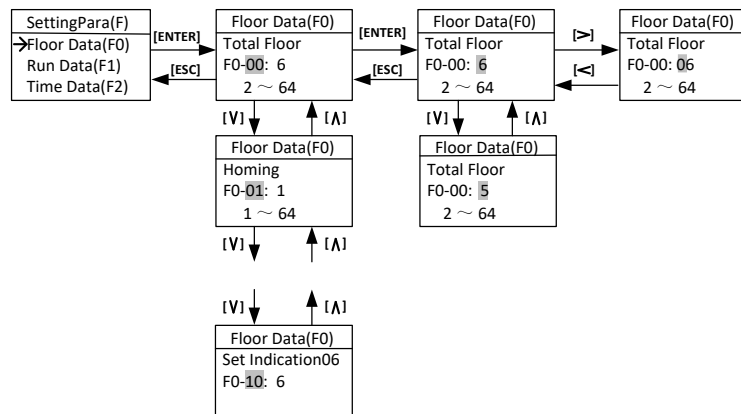

FIGURE 4.4 PARAMETER SETTING

In the interface of parameter menu; Press [ENTER] key to enter the interface. (First, it should input the correct user password in the environment setting menu, otherwise, pressing the [ENTER] key will enter the interface of user password setting. So please pay attention to distinguish the factory password and user password. If you want to input the factory password, please press the [ESC] key, returning to previous menu, then press the [DOWN] key to change the prompt to “input the factory password”, after that press the [ENTER] key, entering to the interface of the inputting factory password). Press the [UP] or [DOWN] key to check all the parameters. Please press the [ENTER] key to enter the interface of parameter menu. Please press [LEFT] or [RIGHT] key to move the arrow to left or right. Press the [UP] or [DOWN] to increase or decrease the value that the arrow point at. After setting the value, please press the [ENTER] key to save the parameter.

Some parameter values are combination values of the status. Their setting cannot follow the above flowchart directly and should follow the ToolTip in the parameter changing interface. Press [RES] key to enter the bit parameter setting interface to set the status value as per the bit. After entering the bit parameter setting interface, press [UP] or [DOWN] key to check the status of the present bit. When the status of the present bit needs to be changed, press [ENTER] key to enter the status change interface. In the status change interface, press [UP] or [DOWN] key to check the status of the present bit, press the [ENTER] key to save the status of the present bit, press [ESC] key to return the Previous Menu. The process of bit parameter setting is shown in Figure 4.5.

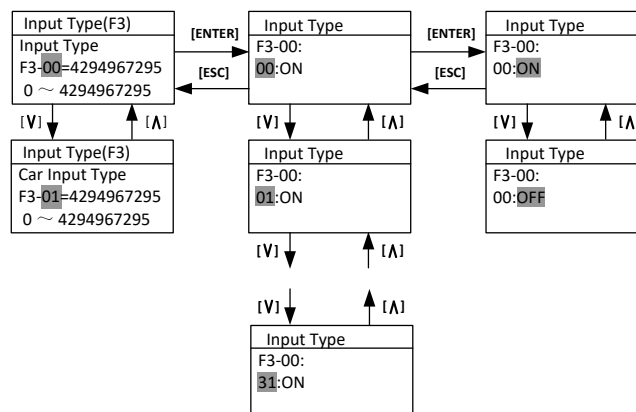

FIGURE 4.5 SETTING BIT PARAMETERS

### 4.4. Commissioning Parameters

In commissioning interface; Move the arrow by pressing [UP] key or [DOWN] key to carry out the operation, press [ENTER] to enter the selected interface.

In floor selection interface; Press [UP] key or [DOWN] key to check the car call status in present floor. If need to set car calls on current floor, press [ENTER] key in the interface to save the car call information. In the interface, the information follows “F;” is the present floor the elevator car at.

Floor selection flowchart is shown in Figure 4.6.

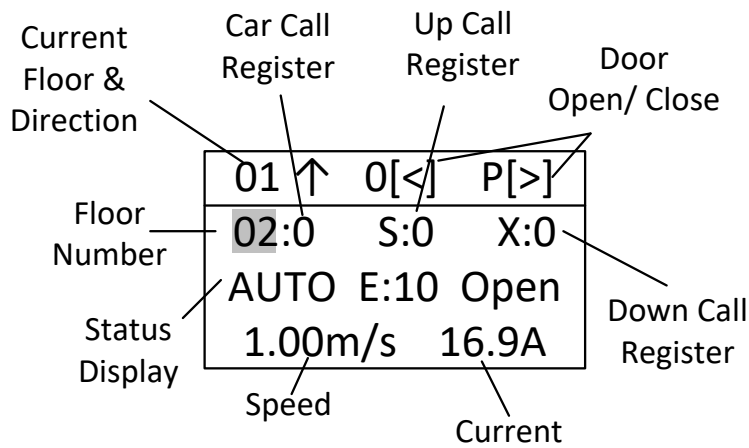

FIGURE 4.6 FLOOR SELECTION

In the interface of door control; Press [LEFT] key in the interface to carry out the command “opening front door”. Press [RIGHT] key to carry out the command “close front door”. Press [UP] key to carry out the command “open rear door”. Press [DOWN] key to carry out the command “close rear door”, Press [RES] key to cancel all the commands.

Door open and close flowchart is shown in Figure 4.7.

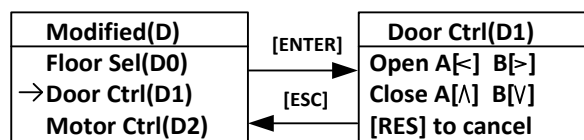

FIGURE 4.7 DOOR CONTROL INTERFACE

In Motor Control interface; Press [UP]/ [DOWN] key to select the running mode is continuous running or JOG. In continuous running mode, press [RUN] key to start motor first, press [UP]/ [DOWN] key to increase/decrease the motor given speed. The motor given speed can be negative (negative speed means motor reverse run), press [ENTER] key to save the given speed. Press [STOP] key to stop the motor. In the mode of JOG, press [UP]/ [DOWN] key to

increase/decrease the JOG operation frequency, after press the [ENTER] to save the setting, and then press the [RUN] key to start and press the [STOP] to stop the operation.

The process of operator to control the motor running is shown below in the Figure 4.8.

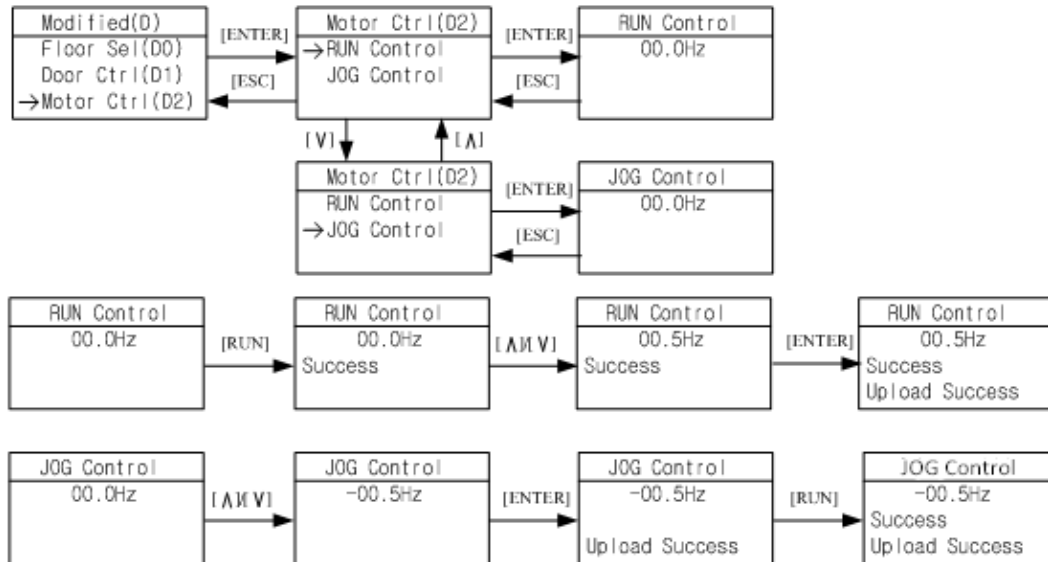

FIGURE 4.8 FLOWCHART FOR OPERATOR TO CONTROL MOTOR RUNNING

In interface of call testing; Press [UP]/ [DOWN] key to check the connections for all floors. Normally, it displays running success, otherwise it shows fails. Press [ESC] key to return to the Previous Menu.

The flowchart for call testing is shown in Figure 4.9.

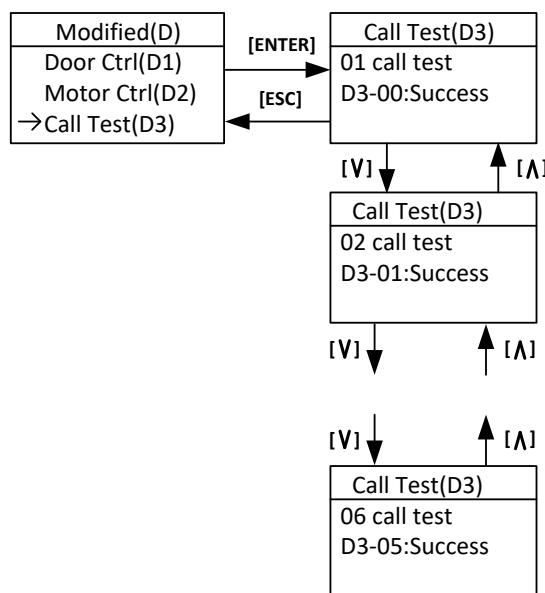

FIGURE 4.9 ELEVATOR CALL TESTING INTERFACE

The interface of communication testing is shown in the Figure 4.10.

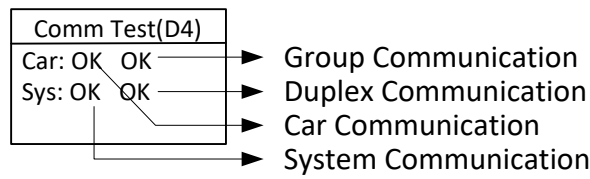

FIGURE 4.10 COMMUNICATION TESTING INTERFACE

The display of the Car Control Communication is as follows;

OK Communication normal

ER Controller receiving data error (please check communication connection & car control board), when there appears a numerical value, it refers to the times of error on car control board communication.

**System communication display**

OK communication good

ET the controller sending data error (please check landing call communication connection), when there appears a figure, it refers to the times of error on system communication.

**Group control communication**

OK Group control system communication normal

ER Group control system communication abnormal (When choose this option)

**Duplex control communication**

OK Duplex control system communication good

ET/ER Duplex control system communication abnormal (When choose this option)

**4.5. Save Parameter**

In the interface of saving parameter, press the [ENTER] to save all the parameters in the F menu. During saving process, LCD will display “Waiting”; after saving, it will display “Success” or “Failure”. The flowchart of saving parameter is shown in the Figure 4.11.

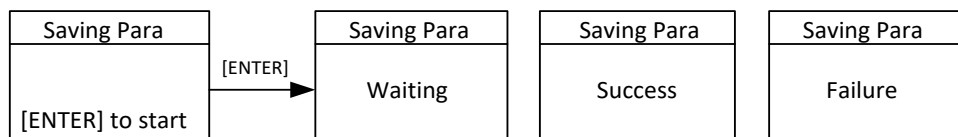

FIGURE 4.11 SAVING PARAMETER

## 4.6. Hoistway Learning

### 4.6.1 For controller program of early version

In hoistway learning interface; when status display “To Down limit”, the hoistway learning cannot start directly. The elevator should manual run to the down limit position first, and “To Down limit” status disappear, the screen will display “[ENTER] to start”, press the [ENTER] key to start hoistway learning. During the learning process, the interface will display the current learning floor and display the status of “Waiting”, when the hoistway learning is completed, the status will display “Success”, when there are errors during the hoistway learning, the status will display “ERR” and display error code. Press [ESC] key to return the Previous Menu.

The flowchart of the hoistway learning is shown in the Figure 4.12.

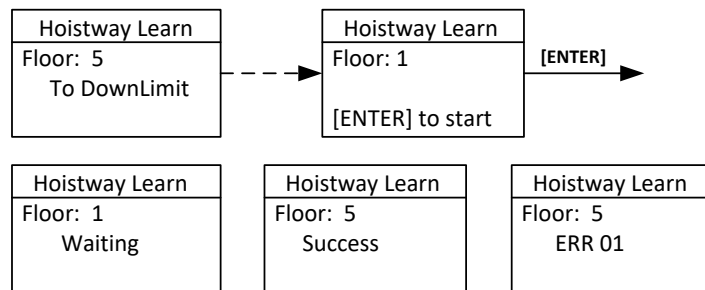

FIGURE 4.12 HOISTWAY LEARNING

### 4.6.1 For controller program of new version

In new version, hoistway learning can be started at any position. After hoistway learning start, elevator will return to bottom limit and stop for 10 seconds, then automatically run upward until top limit to complete hoistway learning.

## 4.7. Motor Auto-tuning

Motor Auto-tuning includes two parts; Motor angle tuning and motor parameter tuning. In the interface of Motor Tune; Press [UP] or [DOWN] key to move the arrow to select related tuning information; Press [ENTER] key to enter the pointed tuning interface.

In the interface of Motor Angle Tuning and Motor Parameter Tuning, press [ENTER] to start turning. During tuning, the operator displays “waiting”; after tuning, it will display “success”. During tuning, if there is error, the tuning process will be terminated, and LCD will display “Tune End”, and the status is “error”, with error code followed.



Before auto-tuning process, make sure to set the parameters in the F5 & F8 menu first.

#### IMPORTANT

Make sure motor has no load, first carry out motor parameter tuning, then carry out the motor angle tuning. Press [ESC] key to return to the previous menu. The flowchart of the motor learning is shown in Figure 4.13.

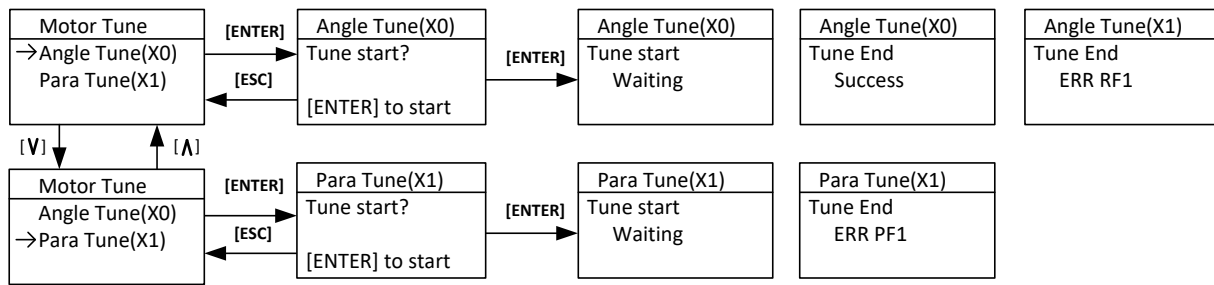

FIGURE 4.13 MOTOR AUTO-TUNING PROCESS

## 4.8. Motor Load Tuning

Motor Load Tuning also includes two parts; Light loaded tuning and Full-loaded tuning.

In the interface of load tuning; Press [UP] or [DOWN] move the arrow to select related tuning information; press [ENTER] key to enter the pointed tuning interface.

In light-loaded tuning or full-loaded tuning interface; Press [ENTER] to start tuning process, the operator displays the present status. Press [ESC] key to return to the Previous Menu.

The load tuning process is shown in Figure 4.14.

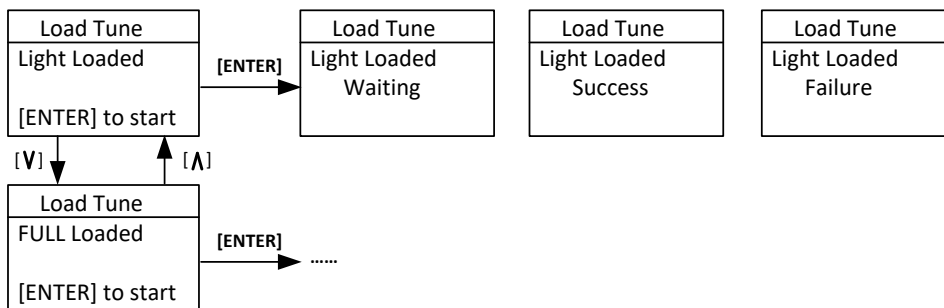

FIGURE 4.14 MOTOR LOAD TUNING PROCESS

## 4.9. Time Setting

In the interface of time setting, the last two digits of “Year”, “month”, “day”, “hour”, “Minute” and “second” are editable, press [LEFT] or [RIGHT] to move the arrow to the right place. Press [UP] or [DOWN] key to change the pointed value. After setting; Press the [ENTER] key to save. Press [ESC] key to return the Previous Menu.

The flowchart of time setting is shown in the Figure 4.15.

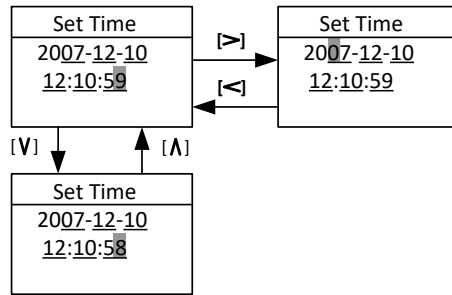

FIGURE 4.15 TIME SETTING

### 4.10. Fault Record Check

In the interface of Fault Record; Press [UP] or [DOWN] key to check the elevator and controller fault record. Press [ENTER] to enter the selected fault record, press [UP] or [DOWN] key to check the latest 30 fault history record.

Each elevator fault record includes error code, time, elevator status at fault (Floor number, running direction, running speed, I/O state), and related information. This helps to find the root cause of the elevator fault and guide the elevator maintenance.

Each controller fault record includes error code, time, elevator status at fault and other important data (Running speed, line/BUS voltage and current). This helps to find the root cause of the controller fault and guide the elevator maintenance.

The flowchart of the fault record check is shown in the Figure 4.16.

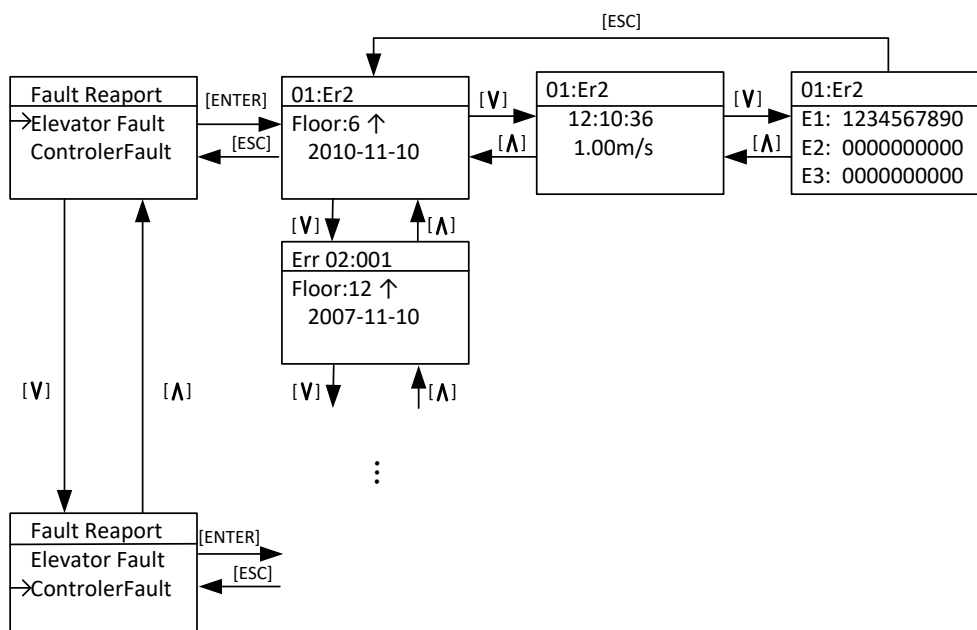

FIGURE 4.16 FAULT RECORD

Press [ESC] key to return to the Previous Menu.

## 4.11. Environment Initialization

In environment initialization interface, the display language, the parameter visit grade, input password and the shortcut menu of the operator can be set.

The flowchart for environment initialization is shown in the Figure 4.17.

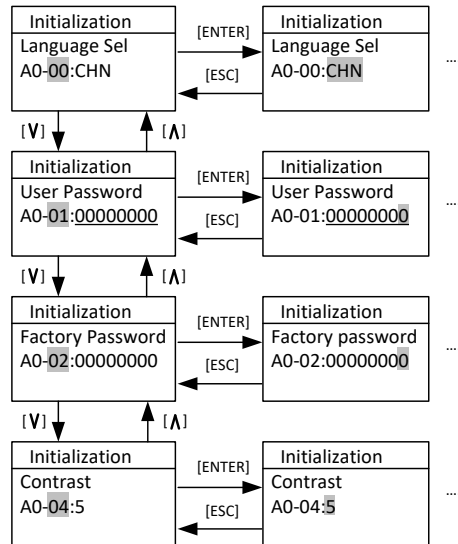

FIGURE 4.17 ENVIRONMENT INITIALIZATION

### 4.11.1 Language Selection

The flowchart for the language selection is shown in the Figure 4.18.

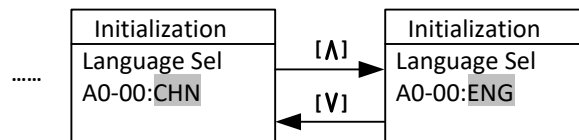

FIGURE 4.18 LANGUAGE SELECTION

Press [UP] or [DOWN] to select language, and press [ENTER] key to save the selection.

### 4.11.2 User password input and setting

In the interface of password, press the [LEFT] or [RIGHT] key to move the arrow to the pointed position, press [UP] or [DOWN] key to increase or decrease the pointed value, press the [ENTER] key to input the password. When password input is incorrect, "invalid password" will be displayed, and the password cannot be changed at this time. When the password input is correct, "Password OK" will be displayed, next press [ENTER] first then press [RES] key to enter the password setting interface and reset the password. Resetting password is similar to input password. Finally press the [ENTER] key to save the new password.

The flowchart of the password input and change is shown in the Figure 4.19.

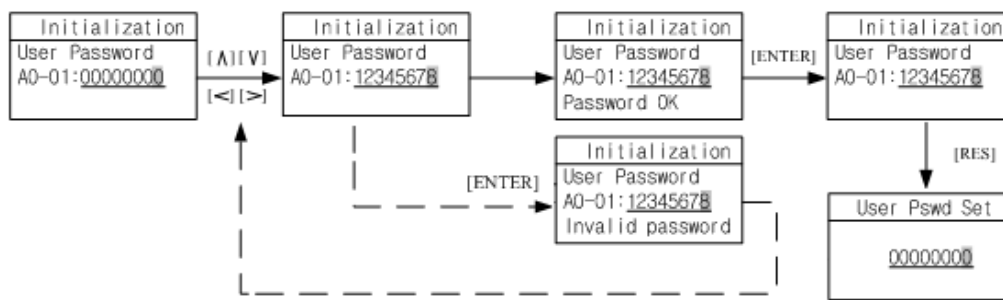

FIGURE 4.19 USER LEVEL PASSWORD INPUT/CHANGE

#### 4.11.3 Factory level password Input and Setting

The process of the factory level password input and setting refers to the user level password input and setting.

#### 4.11.4 Function shortcut keys

For the convenience of function switching, the following sets of function shortcut keys have been set;

1. Switching between Chinese and English modes; On the initial interface of the operator when powered on (i.e. the main interface), press the SHIFT button without releasing it, then press the MENU button without releasing it, wait for 1 second, and Chinese and English will switch;
2. LCD screen contrast adjustment; At the initial interface (i.e. main interface) when the operator is powered on, press and hold the RES button, wait for 1 second, and the brightness of the LCD screen will change;
3. Program version number and font version view; In the initial interface (i.e. the main interface) when the operator is powered on, press the SHIFT button without releasing it, then press the RES button without releasing it, wait for 2 seconds, and the program version number and font version will be displayed.

## 4.12. Parameter Copy

The function parameter copy is to simplify the parameter setting and commissioning process, especially for multiple elevators with same configurations. After finishing the parameter setting and commissioning of one elevator, this function can copy all the parameters (Saved in the digital operator memory), take the digital operator and connect to other elevators, copy all the parameters to the controller, check parameters, and the elevator can run normally.

In the interface of parameter copy; Press [UP] or [DOWN] key to move the arrow to carry on the necessary operation, press the [ENTER] key to start operation.

The flowchart of parameter copy is shown in Figure 4.20.

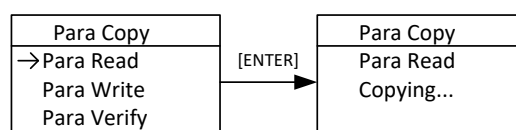

FIGURE 4.20 PARAMETER COPY

After copy operation, LCD display is shown below in Figure 4.21.

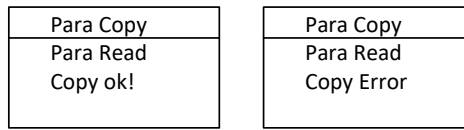

FIGURE 4.21 PARAMETER COPY FINISH

Press [ESC] key to return to the previous menu.

### 4.13. Restore to Factory Setting

If necessary, the controller can be restored to the factory (default) setting. Press the [ENTER] key to restore the factory setting, the interface will display the status and the result.

The flowchart of restore the factory setting is shown in the Figure 4.22.

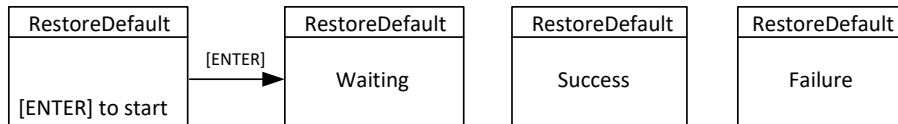

FIGURE 4.22 RESTORE TO FACTORY SETTING

Press [ESC] key to return the previous menu.

### 4.14. Blue-Light Traction machine Parameter Input

When using Blue-Light Integrated Controller, if the traction machine is also made by Blue-Light, you only need to input the machine model number and encoder information on the machine name plate to finish the parameter setting of the machine.

The interface of the Blue-Light machine input is showing in Figure 4.23(a). The input content has three parts, separated by “.”. The first part is the model number (separated in 4 digits), the middle part is encoder resolution information, the last part is the PG model. The detail information is showing in Figure 4.23(b).

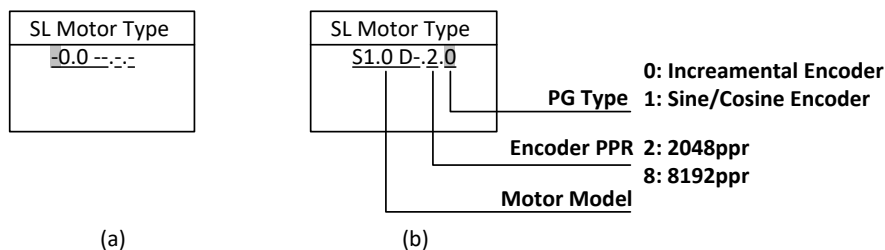

FIGURE 4.23 BLUE-LIGHT MACHINE INPUT

Use [UP] or [DOWN] key to set the content of the pointed area, then press the [ENTER] key to confirm. The cursor is then moved to next bit. If the pointed area is not set, the cursor will not move even you press the [ENTER] key (Except the 4<sup>th</sup> number of the machine model, e.g. S1.0D- as the last number is empty, you can press the [ENTER] key directly to set the next bit).

The flow chart of the Blue-Light machine input is shown below in Figure 4.24 (S0.75D as an example).

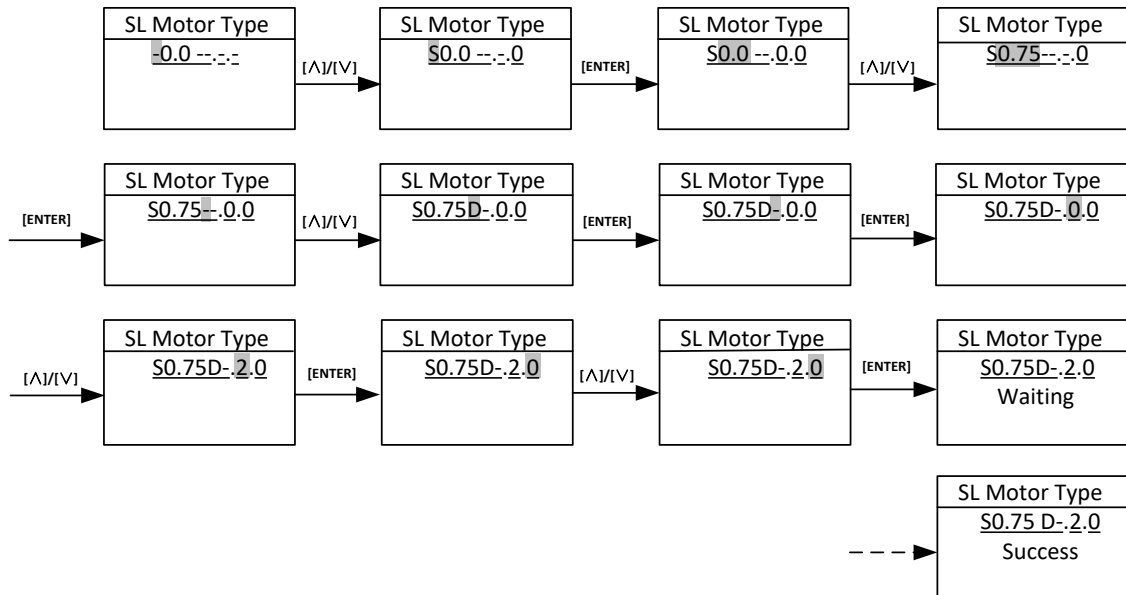

FIGURE 4.24 BLUE-LIGHT MACHINE INPUT FLOW CHART

## Chapter 5 Parameters

### 5.1. Parameters Function Classifications

According to different functions, parameters are divided into groups as shown in chart 5.1.

Chart 5.1 Parameter Functions List

Function Symbol	Function Name
U	Monitoring Parameters
F	Setup Parameters
A	Environment Initialization
D	Commissioning Parameters

### 5.2. Parameters Hierarchical Structure

The hierarchy structure of parameters as shown in Figure 5.1.

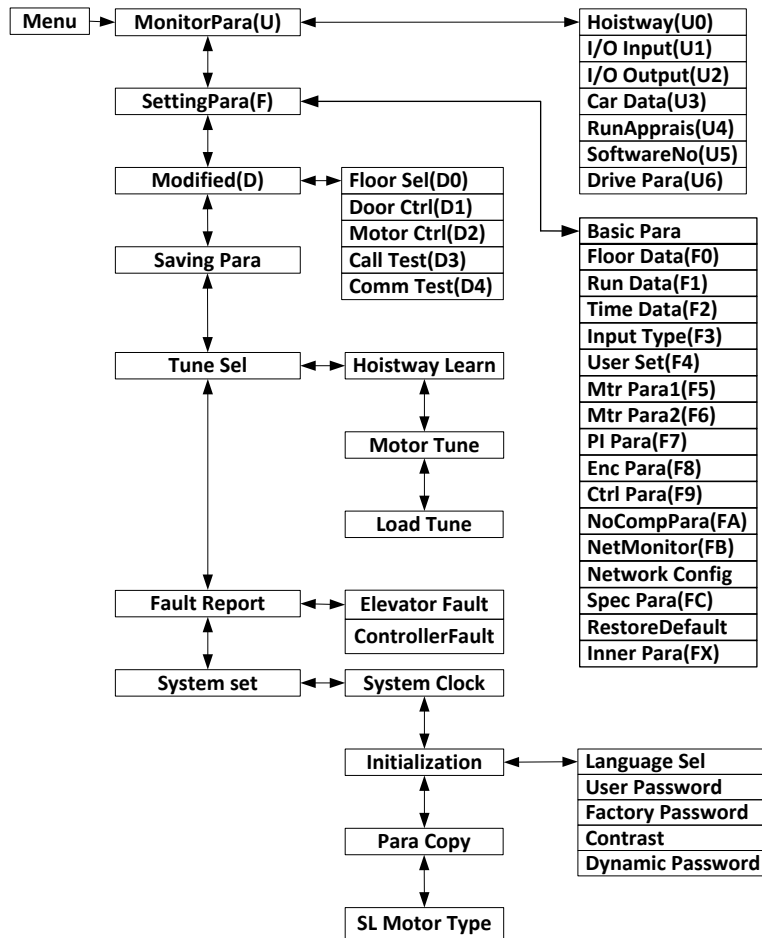

FIGURE 5.1 CONTROLLER PARAMETERS HIERARCHICAL STRUCTURE

## 5.3. Monitoring Parameters

### 5.3.1 Hoistway Location (U0)

Hoistway location parameters refer to the hoistway switches (top/bottom terminal/limit switches) position data on each floor recorded in the controller after hoistway learning process, and the unit is m (meter). If need to calculate the distance between two floors, simply minus the calibration data on these two floors.

After hoistway learning, please check the floor calibration, if the calibration value is higher than expected, it is possible that elevator's rated speed setup is higher than the actual value or elevator encoder pulse setup is smaller than the actual pulse. If the calibration value is too low, it is possible that elevator rated speed setup is lower than the actual value or its encoder pulse setup is larger than the actual pulse.

Hoistway location parameter's number, description and content are shown in chart 5.2

**Chart 5.2 U0 Monitoring Parameter List**

Para No.	Display	Content	Range	Unit	Ref Page
U0-00	Lower Limit	The location of bottom limit in hoistway. Data will be recorded after finishing hoistway learning	--	m	--
U0-01	Upper Limit	The location of top limit in hoistway. Data will be recorded after finishing hoistway learning.	--	m	--
U0-02	Lower Slowdown 1	Location of bottom terminal switch 1in hoistway. Data will be recorded after finishing hoistway learning	--	m	--
U0-03	Lower Slowdown 2	Location of bottom terminal switch 2in hoistway. Data will be recorded after finishing hoistway learning	--	m	--
U0-04	Upper Slowdown 1	Location of top terminal switch 1in hoistway. Data will be recorded after finishing hoistway learning	--	m	--
U0-05	Upper Slowdown 2	Location of top terminal switch 2in hoistway. Data will be recorded after finishing hoistway learning	--	m	--
U0-06 ... U0-69	Floor Data 1...64	The location of floor 1-64 switches in hoistway. Data will be recorded after finishing hoistway learning	--	m	--

## 5.3.2 Monitoring Parameter for I/O Status, Cabin Signal &amp; Interference Appraisal (U1-U5)

Chart 5.3 U1~U5 Monitoring Parameter List

Para No.	Display	Content	Range	Unit	Ref Page
U1-00	Input Data	Controller input data show in decimal type. It will be turned into binary type to show the logical status of the input port.	--	--	29
U1-01	Input Bin	Input port data show in binary type. Each data corresponds to logical status of one input port.	--	--	
U1-02	Input App	Each line corresponds to one input port," On/Off" states the current port status, the following "n" value states the signal appraisal to input level. Value from "10" to "0" refers to interference condition from good (less interference) to bad (large interference)	--	--	
U2-00	Output Data	Display the output port Y0-Y15 current status. The valid output port has the corresponded indication. Port without output (invalid) will be hidden.	--	--	30
U3-00	Car Input Data	Display car input signal status. The valid input port has the corresponded indication. Port without input (invalid) will be hidden.	--	--	63
U4-00	Run Times	Show the elevator accumulated running times. Adopts 10 digital decimal figures as indication	--	Times	--
U4-01	Run Hours	Show the elevator accumulated running hour. Adopts 10 digital decimal figures as indication.	--	Hour	--
U4-04	SendApp1	Signal send appraisal for Duplex and group control. Large number means communication send more mistakes.	--	--	--
U4-05	ReceiveApp2	Signal receive appraisal for Duplex and group control. Large number means communication receive more mistakes.	--	--	--
U4-06	Interfer Apprais	Appraise the value of interference strength at site. The big value refers to strong interference, "0" states no interference and good GND condition.	--	--	--
U4-07	Encoder Apprais	The interference degree of encoder signal. When elevator runs steady, large value states the encoder signal weak with heavy interference.	--	--	--
U4-09 ~ U4-19	Standby monitor	Standby monitor parameter	--	--	--

Chart 5.3 U1~U5 Monitoring Parameters List (Cont'd)

Para No.	Display	Content	Range	Unit	Ref Page
U5-00	CtrlSoftWare NO	Show the elevator control software information. Provide the current software version for factory maintenance and software upgrading.	--	--	--
U5-01	DriveCodeVer	Show the drive control software information. Provide the current software version for factory maintenance and software upgrading.	--	--	--
U5-02	CpldEdition	Show base drive control software information. Provide the current software version for factory maintenance and software upgrading.	--	--	--

For the meaning of input status U1-01 AND output status U2-00, please refer to the control terminal definition chart 3.3. (Page29)

Cabin signal symbol definition and content is shown in chart 5.4. (Page 63).



Chart 5.4 U3-00 Cabin Signal Content &amp; Definition

Cabin signal	Symbol signal	Cabin terminal No.	Content
C00	IGM1	PC1-4	door close 1 input
C01	IKM1	PC1-5	door open 1 input
C02	IGM2	PC2-4	door close 2 input
C03	IKM2	PC2-5	door open 2 input
C04	GMV2	PC2-7	door close limit 2 input
C05	KMV2	PC2-8	door open limit 2 input
C06	GMV1	PC1-7	door close limit 1 input
C07	KMV1	PC1-8	door open limit 1 input
C08	SZY	J5-4 (ZLB)	Special Use Input
C09	IGMYS	J3-4 (ZLB)	door open delay input
C10	SZH	J5-2 (ZLB)	Attendant input
C11	--	--	Empty (for Backup use)
C12	SZS	J6-2 (ZLB)	Bypass drive input
C13	MZ	LW1-4	Full-load input
C14	QZ	LW2-4	Light-load input
C15	CZ	LW1-3	Over-load input
C16	KZ (50%)	LW2-3	50% Full-load (No-load) input
C17	KAB2	KAB2-10	Door safety plate 2
C18	KAB1	KAB1-10	Door safety plate 1
C19	ZHS	J4-2 (ZLB)	Attendance direction up
C20	ZHX	J4-4 (ZLB)	Attendance direction down
C21	LSB1	KAB1-12	New light curtain 1 input
C22	LSB2	KAB2-12	New light curtain 2 input
C23	SMQ	MQ2-3	Modular car top board communication Up door zone
C24	XMQ	MQ2-4	Modular car top board communication Down door zone
C25	--	--	Car Top Inspection Up
C26	--	--	Car Top Inspection Down
C27	--	Internal signal	Lock the door

### 5.3.3 Drive Monitoring Parameters (U6)

Chart 5.5 U6 Drive Monitoring Parameters List

Para No.	Display	Content	Range	Unit	Ref Page
U6-00	Power	Rated power class	--	kW	--
U6-01	Ref Speed	Reference Speed	--	RPM	--
U6-02	Feedback Speed	Feedback Speed	--	RPM	--
U6-03	Load	The current load in % of full load	--	%	--
U6-04	DC Voltage	DC BUS voltage	--	V	--
U6-05	Output Current	Output Current	--	A	--
U6-06	Temperature	Drive internal temperature	--	°C	--
U6-07	Output Torque	Output Torque	--	N·M	--

## 5.4. Parameters setup Function Instruction

### 5.4.1 Building Setup Parameters (F0)

Chart 5.6 Building Setup Parameters List

Para No.	Display	Content	Range	Factory Setting	Unit	Live Change	Ref Page
F0-00	Total Floor	Total floor number (same as door zone plate number)	2~64	6	--	N	--
F0-01	Homing Floor	Without landing/car call elevator will return this floor.	1~Total floor	1	--	N	84
F0-02	Fire Floor	At fire-linkage circuit close, elevator enter fire mode and return to this floor automatically.	1~Total floor	1	--	N	85
F0-03	Parking Floor	When close electric lock in the process of running, elevator return to this floor and stop.	1~Total floor	1	--	N	84
F0-04	VIP Floor	VIP floor setup	1~Total floor	1	--	N	--
F0-05 ... F0-68	Set Indication 1~64	Set indication 1-64, customized character/figure display available	---	1 ... 64	--	N	91



“N” states the parameter cannot be changed in the process of running.” Y” states the parameter can be changed in the process of running. It has same meaning in the following Chart.

## 5.4.2 Parameters for Running Setup (F1)

Chart 5.7 Running Setup Parameters List

Para No.	Display	Content	Range	Factory Setting	Unit	Live Change	Ref Page
F1-00	Car Speed	Elevator speed at motor rated speed. Calculate through motor rated rev, traction ratio, deceleration ratio and traction sheave diameter.	0~4.0	1.6	m/s	N	76
F1-01	Motor Speed	Motor speed at elevator rated speed (Calculated)	1~9999	306	RPM	N	76
F1-03	Insp Speed	Car running speed at inspection cannot exceed 0.6m/s based on relevant standards and regulations	0~0.6	0.3	m/s	Y	76
F1-04	Start Speed	For large resistance at motor start, the starting speed can have smooth increase. The start smooth speed is invalid if set to "0".	0~0.2	0.01	m/s	Y	--
F1-05	Leveling Speed	When elevator park outside door zone due to fault, if satisfy running condition, the elevator can level to door zone with this speed.	0.01 ~ 0.3	0.3	m/s	Y	77
F1-06	Least Speed	Steady speed on the lowest speed curve.	0~1.0	0.5	m/s	N	77
F1-07	Open Door Speed	Car speed when elevator open door in advance is allowed.	0~0.3	0.15	m/s	N	Appendix 2
F1-08	Relevelst Speed	The speed limit for re-leveling. If speed exceeds such value in re-leveling process, the re-leveling will stop with #03 protections.	0~0.3	0.25	m/s	N	Appendix 2
F1-09	Relevelrun Speed	Elevator running speed at re-leveling.	0~0.10	0.05	m/s	N	Appendix 2



When elevator rated speed/Single floor running speed is lower than 0.5m/sec, please properly decrease the acceleration B1, deceleration B2; otherwise it will affect the system calculation of current speed.

IMPORTANT

When user modifies the two speed values out of limit, system will reset to the data before modification.

Chart 5.7 Running Setup Parameters List (Cont'd)

Para No.	Display	Content	Range	Factory Setting	Unit	Live Change	Ref Page
F1-10	Acceleration B1	B1 refers to the acceleration speed curve changing rate, smaller value means elevator start with smooth and gentle increase of speed.	0.1~1.0	0.4	m/s <sup>2</sup>	N	77
F1-11	Deceleration B2	B2 refers to the deceleration speed curve changing rate, smaller value means elevator brake with smooth and gentle decrease of speed.	0.1~1.0	0.4	m/s <sup>2</sup>	N	77
F1-12	S Curve P1	P1; Acceleration speed increase rate at beginning of elevator start; smaller value means beginning of elevator start with slow and steady movement.	0.1~1.0	0.4	m/s <sup>3</sup>	N	77
F1-13	S Curve P2	P2; Acceleration speed decrease rate at end of elevator start; smaller value means end of elevator start with slow and steady movement.	0.1~1.0	0.4	m/s <sup>3</sup>	N	77
F1-14	S Curve P3	P3; Deceleration speed increase rate at beginning of elevator brake; smaller value means beginning of elevator brake with slow and steady movement.	0.1~1.0	0.4	m/s <sup>3</sup>	N	77
F1-15	S Curve P4	P4; Deceleration speed decrease rate at end of elevator brake; smaller value means end of elevator brake with slow and steady movement.	0.1~1.0	0.4	m/s <sup>3</sup>	N	77
F1-16	Zero Speed	Motor speed less than set value, system considers elevator speed as zero and output brake signal.	0~10	1	RPM	Y	81
F1-17	Leveling Adj	Adjust differences of up/down leveling	0~100	50	mm	N	91
F1-18	Load Adj	Normally used in synchronous machine system, compensate elevator load based on steel rope weight difference on each floor.	0~20	0	--	Y	90



**Acceleration B1, deceleration B2, S curve P1, P2, P3, P4 work together to determine the final speed curve and its trend. These parameters have internal relation with each other and are not allowed to change at will. When the modified value is out of limit, the value will recover to the previous data.**

Chart 5.7 Running Setup Parameters List (Cont'd)

Para No.	Display	Content	Range	Factory Setting	Unit	Live Change	Ref Page
F1-21	Drive Mode	Selection of driving mode, when setting "1", attendant/VIP mode close door manually; when setting "3", elevator automatically do test run, other value is invalid. When setting "4", enter the UCMP test mode, see <b>Appendix 10</b> ; when setting "5" temporary shielding limit fault, run to up/bottom limit switch in inspection mode.	0~9	0	--	N	--
F1-22	Two Door Mode	Setup rear door mode, based on customer requirements, set from mode "0" to "5".	0~5	0	--	N	86/87
F1-23	Fire Mode	Three Fire modes; 1.Mode"0"; Elevator run fire-mode after returning to fire floor; 2.Mode "1"; Elevator stop running after returning to fire floor; 3. Mode "2"; After elevator return to fire floor, depend on fire switch to run/stop in fire mode.	0~2	1	--	N	85
F1-24	Parallel No.	Set "YES" in duplex enable. Set elevator number 0-1 in duplex; 0-7 in group control.	0~7	0	--	N	89
F1-25	Twins Control	Elevator duplex control; 1; On 0; OFF	0/1	0	--	Y	89
F1-26	Group Control	Elevator group control; 1; ON 0; OFF	0/1	0	--	Y	90
F1-27	Far Monitor	Remote Monitoring System; 1:On 0:Off	0/1	1	--	Y	--
F1-28	Auto Parking	Auto parking; 1; ON 0; OFF	0/1	0	--	Y	84
F1-29	Load Enable	Load Weighing; 1; ON 0; OFF	0/1	0	--	Y	89
F1-30	Open Delay Able	Door open/close delay; 1; ON 0; OFF	0/1	0	--	Y	83
F1-31	Brake Feedback	Test brake feedback signal; 1; open 0; close	0/1	1	--	Y	79
F1-32	Spare code	Spare code input	0~9999	0	--	N	--

## 5.4.3 Time Setup Parameters (F2)

Chart 5.8 Time Setup Parameters List

Para No.	Display	Content	Range	Factory Setting	Unit	Live Change	Ref Page
F2-00	Brake ON Time	Brake open first then run elevator speed curve. This is to improve the elevator start comfort and match control system with different machine brake on time.	0.00~9.99	1.00	s	Y	79
F2-01	Brake OFF Time	Brake close first then disable elevator run. This is to improve elevator stop comfort and avoid slip at elevator stop.	0.00~9.99	1.00	s	Y	79
F2-02	Insp Brake Time	The time delay in inspection mode before brake closes.	0.00~9.99	0.90	s	Y	79
F2-04	Zero Time	The time delay when system detects elevator stop. Adjust this parameter to close brake after elevator reach 0 speed completely, increase elevator stop comfort.	0~9.99	0.21	s	Y	80
F2-05	Open Door Time	In Auto mode, elevator automatically open door when stopping at one floor, door will automatically close after set time.	0~999	5	s	Y	82
F2-06	Open Delay Time	Enable door open delay function, press open delay button, door open time will be delayed.	0~999	60	s	Y	82
F2-07	Homing Time	The waiting time before elevator return to homing floor without landing/car call, set value to "0" to disable this function.	0~999	60	s	Y	84
F2-08	Door Run Time	1. Door open/close command run time; 2. Door open/close relay run time for door drive without open/close limit switch. 3. For door drive with open/close limit switch, this run time should be 1s longer than the door actual open/close time.	0~999	8	s	Y	83
F2-09	Beep Delay Time	After elevator change speed to target floor, landing signal is delayed by set time, arrival gong/voice synthesizers are also delayed by set time.	0.00~9.99	0.15	s	Y	--
F2-10	Enable Delay	Drive enable signal given/drop is delayed by set time after drive direction signal is given/drop. During this time, drive output current is decreased to reduce current noise.	0.00~9.99	0.40	s	Y	79

Chart 5.8 Time setup Parameters List (Cont'd)

Para No.	Display	Content	Range	Factory Setting	Unit	Live Change	Ref Page
F2-11	Lamp Off Time	In Auto mode, if have no car/landing call during set time, system will cut car light power from COP.	0~999	15	min	Y	--
F2-12	Over Time	To prevent wire rope slipping or elevator car stuck, time from elevator running to stop is limited to set value. If elevator is running longer than set value, system stops immediately and enter protection mode. Need to re-start the system in order to exit from such mode.	0~999	45	s	Y	--
F2-13	SmoothStart Time	The time to keep elevator start smooth.	0.00~9.99	1	s	Y	79
F2-14 F2-15	Start Time	System will automatically start the elevator (Electric lock; ON) at set time.	00;00 ... 23;59	00;00	Hour; minute	Y	84
F2-16 F2-17	Stop Time	System will automatically stop the elevator (Electric lock; OFF) at set time. This function is disabled if same start/stop time.	00;00 ... 23;59	00;00	Hour; minute	Y	84
F2-18 F2-19	Start Time1	System will run bypass the set floor starts from this time.	00;00 ... 23;59	00;00	Hour; minute	Y	
F2-20 F2-21	Stop Time1	System will run bypass the set floor starts until this time.	00;00 ... 23;59	00;00	Hour; minute	Y	



The elevator automatic switch; F2-14, F2-15 F2-16, F2-17 were set separately as per hours and minutes. Please follow the operator indication for this setting.

## 5.4.4 Input type setup Parameters (F3)

Chart 5.9 Input Type Setup Parameters List

Para No.	Display	Content	Range	Factory Setting	Live Set	Ref Page
F3-00	Input Type	Setting the input type on main control panel. Each bit corresponds to one terminal. Set default level of mainboard input port. <b>ON</b> ; Close enable, <b>OFF</b> ; Open enable.	0 ~ 4294967295	4024434 279	N	87/88
F3-01	Car Input Type	Setting the input type of cabin. Each bit corresponds to one terminal. <b>ON</b> ; Close enable, <b>OFF</b> ; Open enable.	0 ~ 4294967295	2147090 191	N	88
F3-02	Input select 1	X13 Input Function Selection	0~32	13	N	
F3-03	Input select 2	X14 Input Function Selection Default F3-03=33(X14 is taken as brake fault detection)	0~32	33	N	
F3-04	Input select 3	X23 Input Function Selection	0~32	23	N	
F3-05	Input select 4	X24 Input Function Selection	0~32	24	N	
F3-06	Input select 5	X25 Input Function Selection	0~32	25	N	
F3-07	output select 1	Y0 Output Function Selection	0~32	0	N	
F3-08	output select 2	Y11 Output Function Selection	0~32	11	N	
		F3-08 content				
		0-11 Instead of Y0-Y11 output.				
		12 Thermistor overheat protection output.				
		15 Alarm closure output (when elevator is running or in door zone with door open, disable the alarm).				
		16 Integrated controller fault indication output.				
		17 UPS shut down the emergency door and cut off the UPS power after 30 seconds.				
		18 Car accident mobile detection, Y11 output trigger rope clamp.				
		19 The output is not valid when it is in automatic, and the output will be prompted under the mode of inspection, firefighting, driver and special-use.				
		20 When the elevator goes up, the signal is output for foreground optoelectronic rope head weighing.				
		21 Emergency output, when X18 outage emergency is valid or peripheral +24V power is invalid.				
		22 Brake resistor fan control output, it outputs to cool down the resistor.				
		23 Retiring cam output for retiring cam with normal state of drawing back.				
		24 Safety relay board power control, only active at destination floor.				
25 Safety relay board power keeps output.						

Chart 5.9 Input Type Setup Parameters List(Cont'd)

Para No.	Display	Content	Range	Factory Setting	Live Set	Ref Page	
F3-09	output select 3	Y10 Output Function Selection	0~32	12	N		
		F3-09					content
		0-11					Instead of Y0-Y11 output.
		12					Thermistor overheat protection output.
		15					Alarm closure output (when elevator is running or in door zone with door open, disable the alarm).
		16					Integrated controller fault indication output.
		17					UPS shut down the emergency door and cut off the UPS power after 30 seconds.
		18					Car accident mobile detection, Y11 output trigger rope clamp.
		19					The output is not valid when it is in automatic, and the output will be prompted under the mode of inspection, firefighting, driver and special-use.
		20					When the elevator goes up, the signal is output for foreground optoelectronic rope head weighing.
		21					Emergency output, when X18 outage emergency is valid or peripheral +24V power is invalid.
		22					Brake resistor fan control output, it outputs to cool down the resistor.
		23					Retiring cam output for retiring cam with normal state of drawing back.
		24					Safety relay board power control, only active at destination floor.
25	Safety relay board power keeps output.						

Note; When using X22 and X23 as multifunctional input port, please make sure the re-leveling device is NOT used.

Note; When using X22 and X23 as multifunctional input port, please make sure the re-leveling device is NOT used.

#### 5.4.5 Service Setup Parameters (F4)

Chart 5.10 Service Setup Parameters List

Para No.	Display	Content	Range	Factory Setting	Live Change	Ref Page
F4-00	Set Stop Floor1	Set elevator stop/bypass at floor corresponds to each bit. (1-32 floors)	0 ~ 4294967295	4294967295	Y	89
F4-01	Set Stop Floor2	Set elevator stop/bypass at floor corresponds to each bit. (33-64floors)	0 ~ 4294967295	4294967295	Y	89
F4-02	TIM Stop Floor1	Set elevator stop/bypass at floor corresponds to each bit at the set time. (1-32floors)	0 ~ 4294967295	0	Y	89
F4-03	TIM Stop Floor2	Set elevator stop/bypass at floor corresponds to each bit at the set time. (33-64 floor)	0~ 4294967295	0	Y	89
F4-04	Door Select A1	Set elevator front door enable /disable at floor corresponds to each bit (ON/OFF; Front door enable /disable at this floor)	0~ 4294967295	4294967295(1~32)	Y	87

Chart 5.10 Service Setup Parameters List (Con'd)

Para No.	Display	Content	Range	Factory Setting	Live Change	Ref Page
F4-05	Door Select B1	Set elevator rear door enable /disable at floor corresponds to each bit (ON/OFF; Rear door enable /disable at this floor)	0~ 4294967295	0	Y	87
F4-06	Function Select	Set elevator functions enable /disable at floor corresponds to each bit. (ON; Enable, OFF; Disable)	0~ 4294967295	538458116	Y	91/ 92
F4-07	Function Select 2	Set elevator functions enable /disable at floor corresponds to each bit. (ON; Enable, OFF; Disable)	0 ~ 4294967295	570425388	Y	92/ 94

Note; See more detail of F4-06 and F4-07, please refer to Chart 6.4.

#### 5.4.6 Motor Setup Parameters (F5-F6)

Chart5.11 Motor Setup Parameters List

Para No.	Display	Content	Range	Factory Setting	Unit	Live Change	Ref Page
F5-00	Motor Type	Set motor type (0; sync- outer rotor, 1; async machine, 2; sync-inner rotor)	0~2	0	--	N	94
F5-01	Poles	Motor poles (Nameplate)	1~99	20	--	N	94
F5-02	Sync Freq	Motor synchronous frequency (Nameplate)	0.001~ 200.000	16	Hz	N	94
F5-03	Rated Power	Motor rated power (Nameplate)	1~999.999	5.1	kW	N	94
F5-04	Rated Speed	Motor rated speed (Nameplate)	1~5000	96	RPM	N	94
F5-05	V IN	Motor counter-EMF (Nameplate)	1~380	280	V	N	94
F5-06	L_phase	Motor phase inductance set. (Auto-tuning/ manual input)	Auto-tuning /Nameplate	16.1	mH	N	95
F5-07	R_phase	Motor phase resistance set. (Auto-tuning/ manual input)	Auto-tuning /Nameplate	2.4	Ω	N	95
F5-08	Rated FLA	Motor rated current. (Nameplate)	0~999.999	12	A	N	95
F5-09	NO-Load Current	For asynchronous machine, no-load excitation current.	0.1~50	0	A	N	95
F5-10	Rated Slip	For asynchronous machine rated slip. (Nameplate)	0.1~10	1.5	HZ	N	95

Chart5.11 Motor Setup Parameters List (Con'd)

Para No.	Display	Content	Range	Factory Setting	Unit	Live Change	Ref Page
F6-00	Carrier Freq	Set controller carrier frequency.	2~12	8	kHz	N	--
F6-02	SpeedZoom	Speed Zoom (Reduce elevator actual running speed)	0~100	100	%	Y	95
F6-03	DirSel	Select motor running direction (0/1; Motor rotates anti-clockwise, car move down/up).	0/1	0	--	--	95
F6-04	Kp	Speed loop proportional gain. (Valid for complete curve if not used in multiple PI.)	0~65535	1000	--	--	96
F6-05	KI	Speed loop integral gain. (Valid for the complete curve if not used in multiple PI.)	0~65535	600	--	--	96

### 5.4.7 Multiple PI Setup Parameters (F7)

Chart 5.12 Multiple PI Setup Parameters List

Para No.	Display	Content	Range	Factory Setting	Unit	Live Change	Ref Page
F7-00	PIMulEnable	Multiple PI parameters 1; Enable; 0; Disable	0/1	0	--	N	96 97
F7-01	PI1 Range	PI available range 1 (Start-middle speed running PI switch frequency)	0~ Rated freq	5	Hz	Y	96 97
F7-02	PI2 Range	PI available range 2 (middle -high speed running PI switch frequency)	0~ Rated freq	0	Hz	Y	96 97
F7-04	PI3 Range	PI available range 4	0~ Rated freq	0.5	Hz	Y	96 97
F7-05	Kp1	PI available range 1 proportional gain	0~2000	1200	--	Y	96 97
F7-06	Kx1	PI available range 1 integral gain	0~2000	900	--	Y	96 97
F7-07	Kp2	PI available range 2 proportional gain	0~2000	1000	--	Y	96 97
F7-08	Kx2	PI available range 2 integral gain	0~2000	600	--	Y	96 97
F7-11	Kp3	PI available range 4 proportional gain	0~2000	600	--	Y	96 97
F7-12	Kx3	PI available range 4 integral gain	0~2000	500	--	Y	96 97

## 5.4.8 Encoder Setup Parameters (F8)

Chart 5.13 Encoder Setup Parameters List

Para No.	Display	Content	Range	Factory Setting	Unit	Live Change	Ref Page
F8-00	Encoder PPR	The encoder pulse count per-revolution.	100~8192	2048	--	N	98/99
F8-02	PG Type	PG card type (0; Incremental encoder, 1; Sine/Cosine encoder)	0/1	1	--	N	98/99

## 5.4.9 Control Setup Parameters (F9)

Chart 5.14 Control Setup Parameters List

Para No.	Display	Content	Range	Factory Setting	Unit	Live Change	Ref Page
F9-00	Max Torq Comp	Maximum torque compensation (torque required to compensate at no load, 100% correspond to machine rated torque.)	0 ~ 100%	0	%	N	89
F9-01	SPDSOURCESEL	Speed given source selection; 0; Simulation; 1; Multi-segment 2; Internal; 3; Operator	0~3	2		N	--
F9-03	Spderr Set	Speed Deviation Set (100% correspond to machine rated speed.)	0~100	5	%	Y	--
F9-11	Load Comp Enable	Load Compensation; 1 enable; 0 Unable	0/1	0	--	N	97/98
F9-13	Load Source Sel	Weighing source (0; SJT weighing, 1; -10-10V weighing, 2; 0-10V weighing)	0/1/2	0	--	N	97/98
F9-19	UP Comp Bias	Up direction (clockwise) Compensation Bias	-100~100	0	--	Y	--
F9-20	DOWN Comp Bias	Down direction (anti-clockwise) Compensation Bias	-100~100	0	--	Y	--
F9-21	FULL Comp Pro	Full load compensation proportion	0~200	100	--	Y	--

## 5.4.10 No-load Compensation Setup Parameters (FA)

Chart 5.15 No-load Compensation Setup Parameters List

Para No.	Display	Content	Range	Factory Setting	Unit	Live Change	Ref Page
FA-00	StratKP	Start-up proportional gain with no compensation.	0~50000	30	--	N	99
FA-01	StratKI	Start-up integral gain with no compensation	0~50000	750	--	N	99
FA-02	ZeroKP	Zero speed proportional gain	0~65535	10000		N	99
FA-03	ZeroKI	Zero speed integral gain	0~65535	5000		N	99
FA-04	ZeroKeepKP	Keep Zero speed proportional gain	0~2000	180	--	N	98
FA-05	ZeroKeepKI	Keep Zero speed integral gain	0~10000	550	--	N	98
FA-08	PLKP1	No compensation effect proportional gain 1	1~6500	2500	--	N	99

Chart 5.15 No-load Compensation Setup Parameters List (Con'd)

Para No.	Display	Content	Range	Factory Setting	Unit	Live Change	Ref Page
FA-09	PLTime	No compensation effect time	1~1000	900	ms	N	99
FA-11	PLKP2	No compensation effect proportional gain 2	0~50000	800	--	N	99
FA-12	PLKPMOD	No compensation effect proportional factor	0~50000	125	--	N	99

#### 5.4.11 Special Parameters (FC)

Special parameters (FC) are mapping a part of factory parameters (FX) in customer level; users can access this part information by user level password. In these parameters, FC-00~FC-06 can only be viewed but not editable, while other parameters can be changed. Special parameters (FC) number, description and content are shown below in Chart 5.16.

Chart 5.16 Special Parameters List

Para No.	Display	Content	Range	Factory Setting	Unit	Live Change	Ref Page
FC-00	Zpulse_Init	Result of motor angle tuning, same as FX-00.	0~3277	0	--	N	--
FC-07	Kplreg	Current ring proportional (FX-07), <b>MODIFY WITH CAUTION!</b>	0~65535	10000	--	N	--
FC-08	Kxlreg	Current ring integral (FX-08), <b>MODIFY WITH CAUTION!</b>	0~65535	5000	--	N	--
FC-13	AutoTuneModeSel	Sine/Cosine PG card auto-tuning selection (FX-20); 0; Rotation; 1; Stationary;	0/1	1	--	N	--
FC-14	N Temp Alarm Ena	Negative temperature alarm (FX-21) 1; Alarm enable at -15C; 0; Alarm disable at -15C.	0/1	1	--	N	--
FC-15	InitTuneEnable	When using Sine/Cosine PG card, whether need CD signal for position at power up 0; Yes.1; No (Can only set to 0 for SPG-V33 and above) Set to 0 can avoid electric noise at first power up.	0/1	0		N	FX-24
FC-16	CD DirSel	FC 15 is available if set to 1. Set to 0 if AB & CD signal in same phase, otherwise set to 1. (Auto selected at motor angle tuning.)	0~3	0		N	FX-25
FC-17	Encode Level	Monitor limitation of sin/cos PG card signal disconnection. (Setting it too small may cause fail to monitor encoder disconnection, please be cautious for changing) (same as FX-26)	0~100	60		N	
FC-18	Torque Limit	Permissible output relative to rated percentage torque limit amplitude.	0~200	185		N	

### 5.4.12 Spare parameters (FD)

Spare parameter (FD) is reserve parameter group, FD-00 to FD-39, totally 40 spare parameters.

#### Bit setting group (FD-05、FD-21、FD-22、FD-23、FD-39);

Each parameter can be set in a numerical range of 0~65535, which is split into 16 special functions of the ON/OFF set in binary way, which opens (ON) for the binary value of 1, and the 0 is closed (OFF).

**Please select the function that you need to open according to the chart 5.17, then set the value of the corresponding position to 1, and then convert the binary value of the whole table to the decimal value to set the FD-XX parameter.**

The formula is as follows;

$$FD-XX = BIT0*2^0+BIT1*2^1+BIT2*2^2+...+BIT15*2^{15}$$

Chart 5.17 Spare parameter table (FD group)

<b>Bit-setting</b>	Bit15	Bit14	Bit13	Bit12	Bit11	Bit10	Bit9	Bit8
<b>Definition</b>	Function 16	Function 15	Function 14	Function 13	Function 12	Function 11	Function 10	Function 9
<b>Bit-setting</b>	Bit7	Bit6	Bit5	Bit4	Bit3	Bit2	Bit1	Bit0
<b>Definition</b>	Function 8	Function 7	Function 6	Function 5	Function 4	Function 3	Function 2	Function 1

#### Setting example 1;

When function 12 is enabled, the binary value is 0000 1000 0000 0000 (Bit15~Bit0, Bit11 is 1, the rest is 0).

Converted to a decimal value of 2048 (2 to the power of 11 =2048).

#### Setting example 2;

Enable function 1, function 2 and function 10 at the same time, the binary value is 0000 0010 0000 0011. (Bit15~Bit0, Bit9, Bit1 and Bit0 are 1, the rest is 0)

Converted to decimal numeric value of 515. (9 square of 2 + 1 square of 2 + 0 square of 2 =512+2+1=515)

Chart 5.18 Special Function Selection 3 (FD-05)

Num.	Function definition	Meaning
FD-05-00	Maintenance operation mode	ON; Open the maintenance operation mode. The main board X5 is the maintenance input signal. It is necessary to reopen this function under the provincial limit mode (F4-07-02=ON), not respond to the call request in the process of maintenance, and the operator is displayed as a special purpose. It only serves the selected instructions in the car and the selected instructions with operating device, which is used for elevator normal running. OFF; Close the maintenance operation mode.
FD-05-01	Earthquake evasion function	ON; Opens the earthquake evasion function. When the main board X21 earthquake input signal is valid, the elevator clears all the registered external call signals, and then open the door to evacuate the passengers at the nearby floor. If the special function parameter F4-07-15 is set to ON, after opening the door, a buzzer sounds every second. When the door is evacuating, the elevator control system determines the current position of the car. If the balance position interval between the weight and the car in the hoistway is found (within the range of positive and negative 2 meters), the elevator enters the circumvention balance position mode, the car tries to close the door, and after the door is closed, the elevator automatically registers an internal selection instruction of the parked floor above the balance position (which can automatically avoid the non-stop floor). Then run upwards to the parked floor to open the door. Then it reports ER25 fault and waiting for the manual reset earthquake monitoring switch to resume the ER25 fault. OFF; Close the earthquake evasion function.

Chart 5.18 Special Function Selection 3 (FD-05) (Con'd)

Num.	Function definition	Meaning
FD-05-02	Inspection run in power off emergency operation	ON; Inspection can run in power off emergency operation; OFF; Inspection cannot run in power off emergency operation.
FD-05-03	ER39 reset method	ON; ER39 error can only be reset once the system successful complete braking force self-test; OFF; In inspection mode, pressing both slow up and slow down buttons for 5 seconds can reset this error.
FD-05-04	Car call cancellation function	ON; Disable car call cancellation function; OFF; Enable car call cancellation function. Click the car call button again can cancel this car call, according to F4-06-09.
FD-05-05	Light curtain abnormal alarm	ON; If light curtain is adhering for more than 2 minutes or it lose effectiveness (no action for 8 continuous car call running), car buzzer will alarm; OFF; Turn off this function.
FD-05-06	Hall door and car door bypass detection method selection	ON; Using SJT-BDD-Vn board to detect hall door and car door bypass, instead of using SJT-ZPC-V2A safety circuit board. When activate this function, car releveing, advance door opening and synchronous machine UCMP testing functions will be disabled. OFF; Using SJT-ZPC-V2A safety circuit board instead of SJT-BDD-Vn circuit board.
FD-05-07	Recover torque of door motor when power on	ON; If power on at leveling position, at first time of closing, it will close both front and rear door. If power on at non-leveling position, it will output both front and rear door close for 5 sec. OFF; Turn off this function. When power on, if door close limit is valid, it will not output close door.
FD-05-08	Door Bypass testing retry	ON:Enable this function. While door bypass testing, if it detects Er92, it will start fault protection. Then if light curtain and open door button are not active, it will automatically close and open door for 2 times then test again. If the test pass, the fault will be automatically reset. If the test fail for 3 times continuously, the fault will be locked and won't retry. OFF:Disable door bypass testing retry.
FD-05-09	Inspection operation in car	ON:Enable inspection operation in car. Original non-stop signal (C12) will become car inspection input, original attendant up (C19) will become inspection up, original attendant down (C20) will become inspection down. OFF:Disable inspection operation in car.
FD-05-10	Car call cancel	ON:Double click to cancel car call.
FD-05-11	Keeper's floor function	ON: Enable keeper's floor function. Duriing 10 PM to 6 AM, each time elevator pass by F0-04 floor (VIP floor), it will stop and open door, then run to destination floor.
FD-05-12	Spared	Reversed parameter, don't set to ON.
FD-05-13	Single brake force testing	ON:While using two brake contactors, test single set of brake force; OFF:While using single brake contactor, test two sets of brake together and use communication type brake power board. This parameter don't need to set.
FD-05-14	Star-sealed self-test	ON:Enable star-sealed self-test function; OFF:Disable star-sealed self-test function.
FD-05-15	Electric star-sealed	ON:Enable electric star-sealed, this function need to work with relative drive module. OFF:Disable electric star-sealed.

Chart 5.19 Spared parameter 7 (FD-06)

Num.	Function definition	Meaning
FD-06-00	7588-2020 enable	ON:Enable new standard functions;OFF:Disable new standard functions.

Chart 5.19 Spared parameter 7 (FD-06) (Con'd)

Num.	Function definition	Meaning
FD-06-01 ~ FD-06-15	Spared	Spared parameter, don't set to ON

Chart 5.19 Drive Special Function 1 (FD-21)

Num.	Function definition	Meaning	default
FD-21-00	Shielded input phase deficiency protection	Set to 1, will shield the input phase deficiency protection function	0
FD-21-01	Spare	Factory spare, do not set it	0
FD-21-02	Shielded output phase deficiency protection	Set to 1, will shield the output phase deficiency protection function	0
FD-21-03	Shielding open/shorted circuit inference protection	Set to 1, shield the first power on short circuit to inference protection function. If the external fault condition is not relieved and shield it directly, the power module will be damaged.	0
FD-21-04	Shielding temperature adaptive protection	Set to 1, shielded temperature adaptive protection function	0
FD-21-05	Shielding voltage drop adaptive protection	Set to 1, shielded voltage drop adaptive protection function.	0
FD-21-06	Spare	Factory spare, do not set it	0
FD-21-07	Shielding automatic calculation of motor pole logarithm	Set to 1, shielded automatic calculation of motor pole logarithm function.	0
FD-21-08 ~ FD-21-14	Spare	Factory spare, do not set it	0
FD-21-15	Increase deceleration rate of torque cancellation when stop	Set to 1, increase deceleration rate of torque cancellation when stop. Sometimes need to increase F2-10 to ensure the integrity of torque cancellation process.	0

Chart 5.20 Drive Special Function 2 (FD-22)

Num.	Function definition	Meaning	default
FD-22-00 ~ FD-22-02	Spare	Factory spare, do not set it	0
FD-22-03	Shielding No.159 drive fault	Set to 1, shielding No. 159 drive fault. Please use this function cautiously. If external disturbance is not released, it will cause motor stall and safety risk.	0
FD-22-04	PWM Fan Enable	Set to 1, the system starts or stops the fan according to the real-time temperature in the driver board, if the temperature is higher than 45 degrees, the fan starts, when below 40 degrees, and the fan automatically stop.	0
FD-22-05	The first power on automatically enters the motor static tuning	Set to 1, every time the system is powered up, the motor static tuning will be started for the first running, and the original value of FC-00 will be recalibrated.	0
FD-22-06	Forced drive mode enabled	Set to 1, the control system will realize advance torque compensation according to the forced drive mode. This function is restricted to the elevator system with forced drive mode and cannot be used for traction mode. Refer to <b>Appendix 20 Forced Drive Mode Instruction</b> for details.	0

Chart 5.20 Drive Special Function 2 (FD-22) (Con'd)

Num.	Function definition	Meaning	default
FD-22-07 ~ FD-22-15	Spare	Factory spare, do not set it.	0

Chart 5.21 Drive Special Function 3 (FD-23)

Num.	Function definition	Meaning	default
FD-23-00	Perform high voltage range when braking and over-voltage on DC Bus	Set to 1, high voltage mode. If input voltage limit is higher than 480VAC, it need to be set, otherwise it will damage power module and braking resistor.	0
FD-23-01 ~ FD-23-15	Spare	Factory spare, do not set it.	0

Byte setting group (FD-04, FD-07, FD-25, FD-26, FD-27);

Chart 5.23 Spare parameter (Byte setting group)

Num.	Function definition	Meaning	Range
FD-00	Duplex support time	If one elevator in duplex is busy, the other elevator will support it after support time.	1~30s
FD-01	Single leveling sensor	When set to 1, it permits single leveling sensor.	0~1
FD-02	UPS open delay	In ARD mode, the time for door keep opening.	10~30
FD-03	IC card address	Inner parameter, do not set it.	0~65535
FD-04	Maintenance reminder function	Set FD-04 to non-zero number to activate maintenance reminder function, this number means the maintenance period in days. For example, set FD-04=100, which means the maintenance period is 100 days. Thus, this elevator needs to have maintenance at least once in 100 days, otherwise, it cannot operate. Car display and hall display will indicate 'MO'.	0~1000 day
FD-07	Weighting offset coefficient	Used to set weighting offset coefficient, set to 0 or turn off the load weighting enable function (F1-29=0) will disable this function. When it sets to a non-zero value, the weighting value will have this amount compensation in its positive direction.	0~100%
FD-08	ARD running speed	Elevator running speed in ARD mode	0.05~0.3m/s
FD-09	Auto running test	If FD-09 is set to a non-zero value, in AUTO mode (not attendant or VIP or fire mode), elevator will automatically perform continuous running test without door automatic open. Each time elevator arrive, FD-09 value will minus 1. While no service, there will be a random car call or hall call until FD-09 becomes 0, then exit. Parameter will be automatically saved if test complete or power off. <b>Note; System default setting is continuous running without door automatic open. If customer need door automatic open, turn to inspection mode and set F4-07-31=OFF after entering testing mode, then turn to auto mode. It will perform continuous testing with door automatic open.</b>	0~65535

Chart 5.23 Spare parameter (Byte setting group) (Con'd)

Num.	Function definition	Meaning	Range
FD-10	Running speed set	If FD-10 is not 0, the value will be taken as maximum running speed of elevator (unit; cm/s). If it is set to 0, disable this function. For example, elevator rated speed is 2m/s. Set FD-10=150, elevator rated speed will be changed to 1.5m/s. If set FD-10=0, elevator rated speed will be 2m/s.	0~rated speed cm/s
FD-17	Password protection function	When set FD-17=1, it will enable password protection function for factory password and customer password. This function must be used with new operator, otherwise it can only read parameter but cannot set parameters.	0~65535
FD-18	Leveling Plate Length	While FD-01=1 (single leveling sensor mode), set FD-18 for the length of leveling plate (unit;mm). If total floor is more than 2 floors, FD-18 can be set no more than leveling plate length. For elevator with only two floors, FD-18 need to set as precise value. In this mode, 2cm out of top and bottom leveling position is inspection limitation. 8cm out of leveling position is limitation of auto mode.	5~500mm
FD-24	Destination value of braking force testing	The destination value setting for braking force testing	125~150%
FD-25	Rope slipping mode	After setting FD-25 to 1, the system enters the slipping mode. At this time, pressing slow up / slow down button, the system will output the limiting current, so that the limit slip state of the rope can be observed. After setting FD-25 to 1, set the non 1 value again, that will be automatically cancel the slipping mode.	0~5
FD-26	Balance coefficient of elevator	Balance coefficient of elevator. (Unit, %)	40~50
FD-27	The ratio of the output current when elevator is empty loaded and travelling downward, to the rated current of motor	The ratio of the output current when elevator is empty loaded and travelling downward, to the rated current of motor. (Unit, %)	30~130%

Note; For 26, 27, please see Appendix 10. V Series Elevator Integrated Controller UCMP (Unintended Car Movement Protection) Function Testing Procedure for details; For FD-25, please see Appendix 11. V9 Series Elevator Integrated Controller Rope Slipping Mode Testing for details.

### 5.4.13 Environment Setup Parameters (A)

Chart 5.24 Environment Setup Parameters List

Para No.	Display	Content	Range	Factory Setting	Unit	Live Change	Ref Page
A0-00	Language Sel	Language selection	--	ENGLISH	--	Y	--
A0-01	User Password	Input/Setting user level password	000000~999999	000000	--	Y	--
A0-02	Factory Password	Input/setting factory level password	000000~999999	000000	--	Y	--
A0-04	Contrast	Setting the LCD contrast level	0~10	5	--	N	--

## Chapter 6 Parameters Setup

### 6.1. Elevator Running Speed Setup

#### 6.1.1 Elevator Rated Speed, Motor Rated Speed, Encoder pulses Setup

1. Elevator rated speed (F1-00) can be calculated through motor RPM, traction ratio, reduction ratio and traction sheave diameter.



Elevator rated speed is used for calculating the ratio between motor rated speed and elevator speed, modifying this parameter cannot change the actual running speed of elevator; if need to change elevator running speed, please modify parameter F6-02 (Speed Zoom)

2. Motor rated speed (F1-01) is the speed of traction machine (RPM) under elevator rated speed.
3. Encoder Pulse (F1-02) is the pulse number of the encoder for hoistway counting at elevator running.
4. Motor rated speed and elevator rated speed much follow the condition below;

$$\text{Elevator rated speed} = \frac{\text{Motor RPM} \times \text{traction sheave diameter} \times 3.14 \times \text{speed reduction ratio}}{60 \times 1000 \times \text{traction ratio}}$$

**For example;** Motor rated speed is 1370 rev/min., traction sheave diameter 590mm, speed reduction ratio; 2/53, traction ratio 1/1, then;

$$\text{Elevator rated speed} = \frac{1370 \times 590 \times 3.14 \times 2}{60 \times 1000 \times 1 \times 53} = 1. \frac{6m}{s}$$

After setting elevator rated speed, motor rated speed, encoder pulse number, system record the relationships between traction ratio, speed reduction ratio, traction sheave diameter and relationships between shaft counting pulse and running distance. If the setting is incorrect, the following problems may happen;

- 1) The elevator running speed on digital operator or software is different with the elevator actual running speed.

For example, if encoder pulse or motor rated speed is set to a smaller value, speed indicated on the display will be higher than actual speed, after hoistway learning, floor height learned by the system will be larger than actual height.

- 2) As the floor height learned by the system is higher, the elevator deceleration curve will be steeper than the setting. This could result elevator cannot get leveling sometimes (running out of leveling zone with sudden brake).

#### 6.1.2 Inspection Run Speed

In inspection mode, elevator runs in slow inspection speed (F1-03), based on international standard, such speed should be no more than 0.6m/s. After elevator reaches top or bottom terminal, the running speed will be reduced to half of the inspection speed.

If bottom/top terminal (X8/X7) is valid, elevator slow down to 1/2 inspection speed to prevent exceeding the limit.

When up/down jogging is cancelled, speed given will be instantly 0 without deceleration curves.

### 6.1.3 Rescue Speed

In both case the elevator will run in rescue speed (F1-05);

1. Due to fault or other reasons, elevator stops outside leveling zone, after elevator restores, it runs in rescue speed to the nearest floor and open door to release passengers;
2. When there is a hoistway counting error (ER14, Er18), elevator will run at rescue speed to the bottom floor for recalibration; After elevator reaches the bottom terminal, elevator will run at 1/2 of rescue speed to the bottom leveling position.

### 6.1.4 Least Speed

Least speed curve (F1-06) limits the lowest speed generated in the system. System will choose the elevator speed based on running distance, but the lowest speed is limited here. For certain site with very small floor distance, reduce this value could achieve normal running on this floor. Otherwise elevator cannot park at small distance floor, it will stop at the next floor.

## 6.2. Normal Running Speed Curve

Elevator can generate several optimal running curves based on rated speed setting to suit for different speed/distance running. But note lowest running speed curve is limited by F1-06.

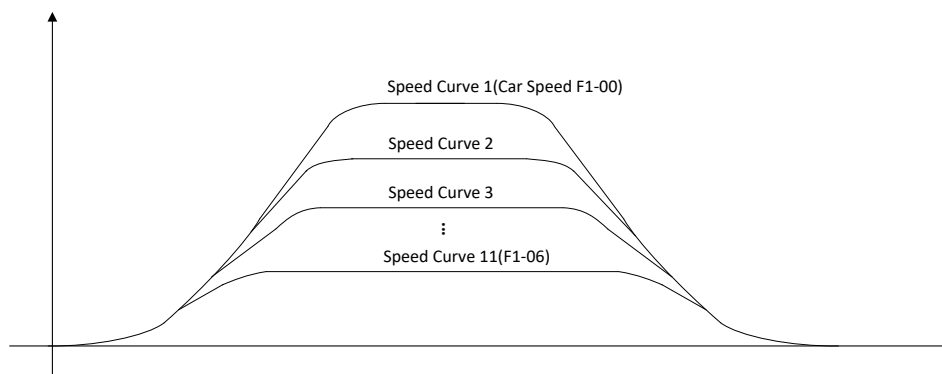

FIGURE 6.1 ELEVATOR RUNNING SPEED CURVE

Acceleration, deceleration for normal running curve and Acce/Dece for S curve are set by the following parameters;

1. F1-10 (Acceleration B1)
2. F1-11 (Deceleration B2)
3. F1-12 (S curve P1)
4. F1-13 (S curve P2)
5. F1-14 (S curve P3)
6. F1-15 (S curve P4)

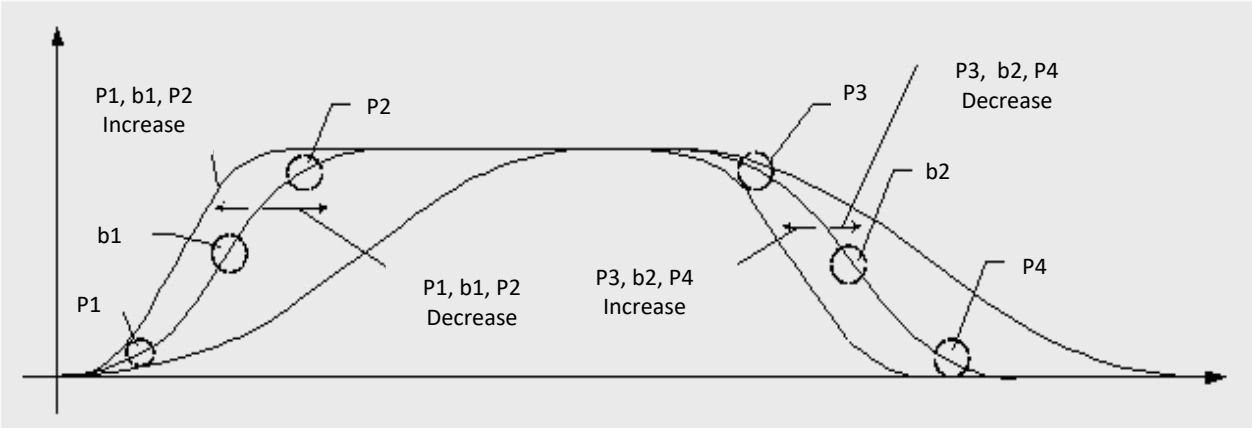

FIGURE 6.2 PARAMETERS ADJUSTMENTS FOR SPEED CURVE

- ✧ Elevator running comfort level can be set through the above 6 parameters. (Comfort level is also related to the drive control parameters.) The relationship between **b1, b2, P1, P2, P3, P4** and running curve are shown in Figure 6.2.
- ✧ Increase parameters value, the corresponded curve will be steeper. While decreasing value will smooth the corresponded curve. Adjusting the above six parameters properly can reach good comfort level at elevator running and meet the related standard.

### 6.3. Elevator Running Timing Diagram

#### 6.3.1 Timing Diagram for Normal Running

The timing diagram for normal running is shown below in Figure 6.3.  
 If smooth start running speed (F1-04) is set to "0", smooth start running function will be disabled; smooth start time (F2-13) will be disabled too.

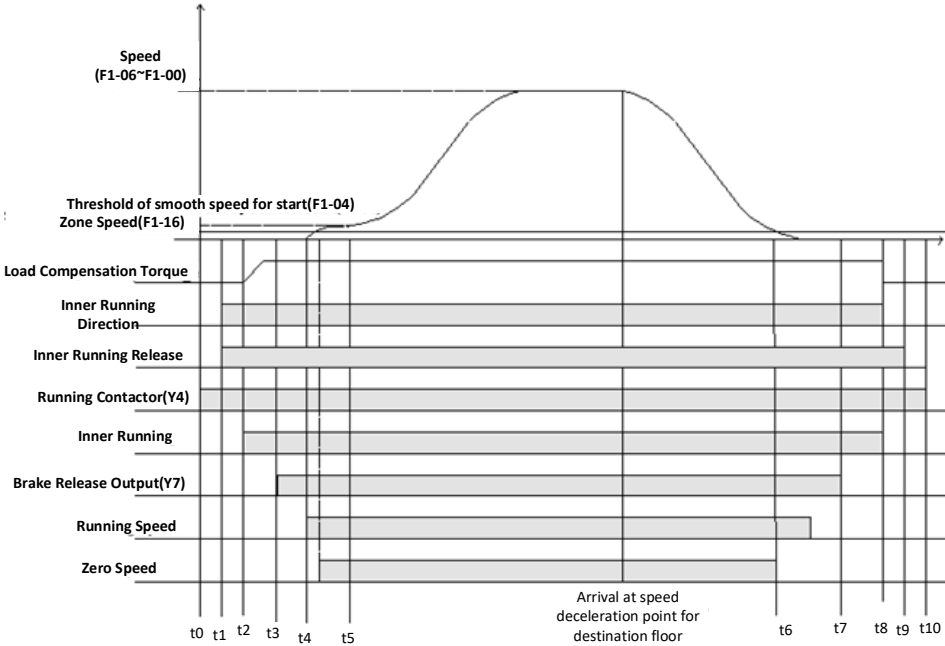

FIGURE 6.3 ELEVATOR TIMING DIAGRAM FOR NORMAL RUNNING

Detail explanation of timing diagram for elevator normal running is explained below in Chart 6.1

**CHART 6.1 TIMING DEFINITION FOR ELEVATOR NORMAL RUNNING**

Time	Definition and Setup Instruction
t0~t1	Control system will first output running contactor (Y4) command; check for feedback time, if valid then system will give running direction and enable driving control based on the given direction.
t1~t2	Driving module output torque.
t2~t3	Waiting time for internal running signal (F2-03); In this period, driving module complete motor excitation or finish load compensation torque output.
t3~t4	Brake advance release time (F2-00); System output brake release command (Y7), brake release and brake arm feedback valid (e.g.F1-31=1), waiting for brake advance release time (F2-00), and then running speed is given. Two functions for brake advance release time (F2-00); 1. Brake has enough time to release completely; this can avoid elevator startup with brake. 2. After brake release, traction sheave may rotate due to the load, with enough time traction sheave can be steady at zero speed then start in order to achieve comfort feeling at start. Based on the brake condition, set 0.8-1.5s for synchronous machine, and 0.3-0.5s for asynchronous machine.
t4~t5	Smooth start time (F2-13); Elevator runs in start smooth speed (F1-04) for a period at start up, this is to overcome part of the elevator static friction. This is normally set as 0.2s-0.4s, setting it too long may reduce the elevator start efficiency.
t6~t7	Zero speed time (F2-04); When elevator runs to the destination floor and speed is lower than the zero-speed limit (F1-16), after zero speed time (F2-04), brake release output is disabled. If zero speed time is set too short, brake may close before elevator completely stop. Normally this value is set to 0.2s-0.4s.
t7~t8	Braking time (F2-01); After brake close, due to the subsequent flow and demagnetization, brake cannot lock on the traction sheave immediately and torque output is kept in the meantime. After braking time, system drop internal direction command and torque output. This time can prevent the elevator slip due to braking lag. Based on the brake condition, set 0.8-1.5s for synchronous machine, and 0.3-0.5s for asynchronous machine.
t8~t9	After system drop internal direction command, stop output current immediately may generate large current noise. Time delay (F2-10) can be set to decrease output current gradually, finally stop the elevator after dropping the internal direction command.
t9~t10	Time delay for running contactor open is 0.4s to prevent electric arc when contactor opens with current. But braking, emergency stop, door lock protection does not have time delay, they act immediately.

### 6.3.2 Timing Diagram for Inspection Running

Timing diagram for elevator inspection running can be seen below in Figure 6.4.

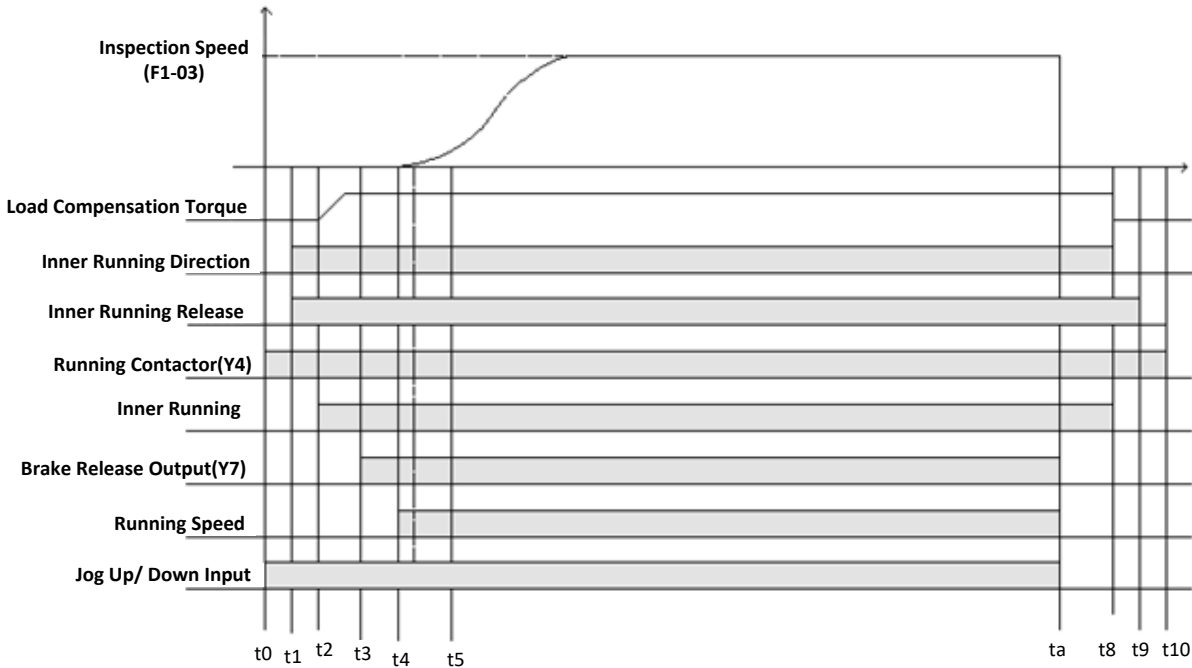

FIGURE 6.4 TIMING DIAGRAM FOR ELEVATOR INSPECTION RUNNING

Definitions and instructions for timing diagram above are shown below in Chart 6.2.

Chart 6.2 Timing Definition for Elevator Inspection Running

Time	Definition and Setup Instruction
t0~t9	Definition for t0~t9 are the same with elevator normal running
ta~t8	Inspection braking time (F2-02); At inspection running stop, system will not wait for elevator zero speed to close brake. When jogging up/down instruction is dropped, brake will close at once (with speed). For some asynchronous traction machines, holding time for torque output too long will result system trigger over-current protection. In this case decreasing the braking time can eliminate such protection. For synchronous machine control, this value should be same under normal running and set as 0.8s-1.5s, for asynchronous machine control, this value should be set as 0.1s-0.3s.

### 6.3.3 Timing Diagrams for Rescue Running

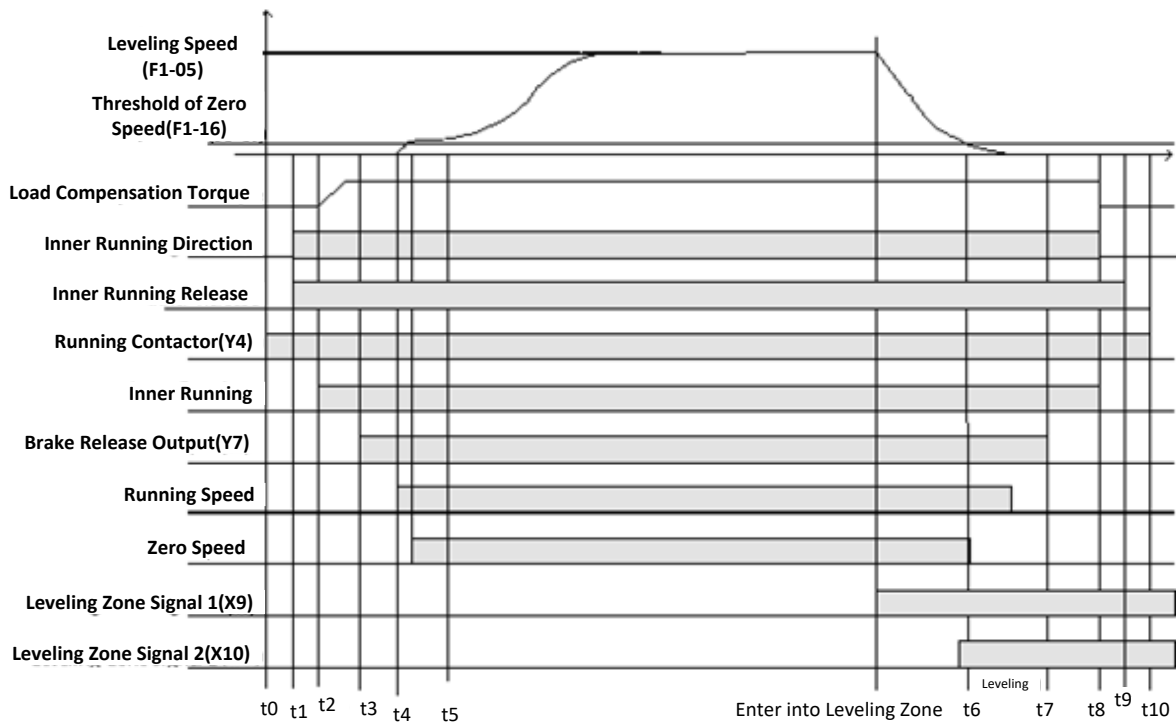

FIGURE 6.5 TIMING DIAGRAMS FOR RESCUE RUNNING (SAME DEFINITION & SETTING WITH NORMAL RUNNING)

### 6.3.4 Timing Diagram for Recalibration Running

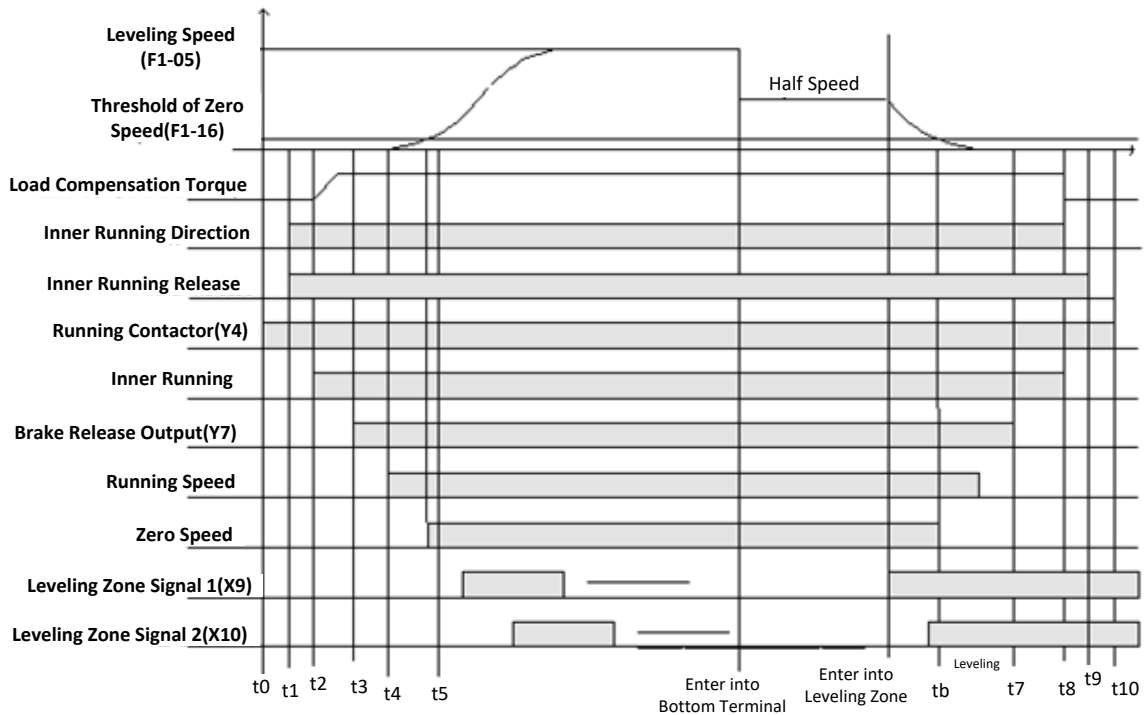

FIGURE 6.6 TIMING DIAGRAMS FOR RECALIBRATION RUNNING (SAME DEFINITION & SETTING WITH NORMAL RUNNING)

## 6.4. Door Control

### 6.4.1 Door Open/Close Control

For door control, door open and close time is the related parameter; door limit is the related signal. Timing diagram for door open and close can be seen below in Figure 6.7 and Figure 6.8.

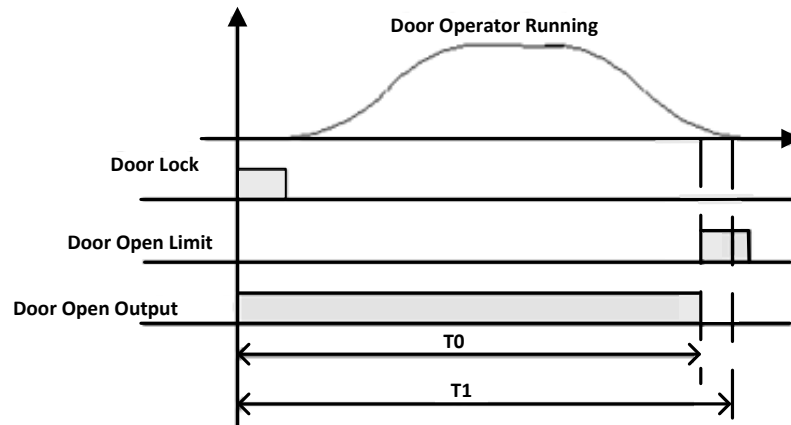

FIGURE 6.7 TIMING DIAGRAM FOR DOOR OPEN

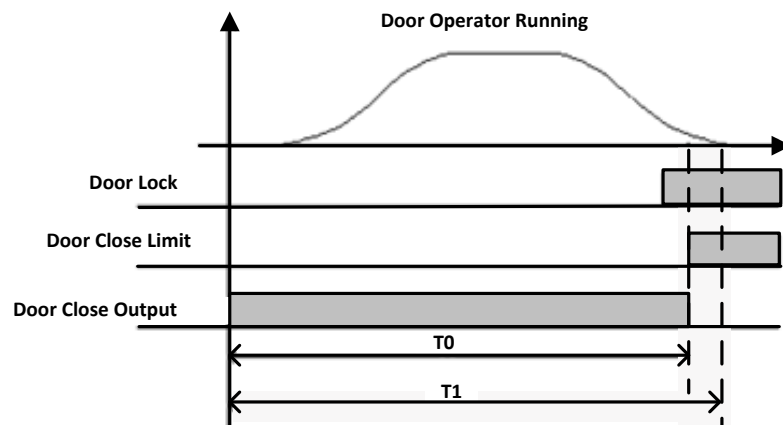

FIGURE 6.8 TIMING DIAGRAM FOR DOOR CLOSE

T0; The actual door-drive running time for door to open or close completely;

T1; Door open or close time (F2-08).

T1 should be 1s more than T0 to ensure the door normal open/close action, otherwise;

1. After system output door close signal, but door does not close completely after T1 door close time (F2-08), elevator will open the door again, and door cannot be closed.
2. After system output door open signal, but door does not open completely after T1 door open time (F2-08), elevator stops the door open action, and door cannot reach the self-lock position.

Door close limit should be fixed in the position where it is only valid after door is completely closed, otherwise;

1. Door cannot close in inspection mode.
2. Door close limit valid, system stops output door close signal, door cannot close, system open the door again.
3. Door close limit is valid, system will open door after set time in F2-08. Door can still be closed under the holding force of door drive, but system will show a door close error, and elevator can run normally.

If the door open/close limit switches cannot be valid after installation, elevator will control door open/close based on time set in F2-08. If door open/close limit signals are normal; the control of door open and close will be based on door open/close limit signals.

### **6.4.2 Door Open Holding Time**

Elevator run in auto mode, after landing, door open, and door will hold for following time;

1. After landing, door open, if elevator has no landing/car call, waiting time is door open holding time (F2-05).
2. After landing, door open, if elevator has only landing call, waiting time is door open holding time (F2-05) minus 2s.
3. After landing, door open, if elevator has both landing/car calls, waiting time is twice of door open holding time (F2-05) minus 2s.
4. If door open delay time (F1-30) is valid (Set as 1), and after door open, door open delay button is pushed, waiting time will be door open delay time (F2-06). After the delay time or press door close button to close door in advance and then reopen door again, door open delay function will be cancelled, unless push door open delay button again after door is open.
5. When elevator enables disabled function, if there are disabled landing/car calls on current floor, waiting time will be door open delay time (F2-06).

### **6.4.3 Door Control in Attendant and Special use mode**

In attendant/special use mode, door must be closed manually. If door driving mode (F1-21) is set to 1, door close will be jog mode, if set to 0, door will close completely after pushing door close button, no need to push the button continuously.

### **6.4.4 Door Control in Inspection, Fire mode**

In inspection mode, door open and close are both jog mode based on international standard.

Door control in fire-mode;

1. In fire mode, if elevator is running, elevator will land to the nearest floor but does not open door, then elevator return to fireman floor.
2. In fire mode, if elevator stops at another floor, door will not open after fully closed, then elevator return to the fireman floor. If door is open, door will close at once, but before the door is completely closed, the door can be opened again by pushing the door open button.
3. If elevator is at the fireman floor, it will open door and hold.
4. In fire mode, except on fireman floor, on all other floors, door can only be controlled in jog mode.

## 6.5. Homing Function Setup

Elevator in auto mode (no duplex/group control), if there are no landing/car calls in set time, elevator will return to homing floor.

1. Set homing floor (F0-01)
2. Set homing time (F2-07), this function is disabled if set homing time to 0.

## 6.6. Parking Function Setup

Normal elevator lock input;

1. Electric lock input (X20) invalid, elevator in auto mode, it will return to parking floor (F0-03) after finishing all car calls.
2. Electric lock input (X20) invalid, elevator in attendant/special use mode, as door cannot close automatically, after finishing all car calls, door must be closed manually, elevator will then return to parking floor.
3. Electric lock input (X20) invalid, elevator in inspection mode, it will be locked at once.

Automatic Start/Stop;

1. Electric lock input (X20) valid, set auto parking (F1-28) as 1, automatic start time (F2-14), automatic stop time (F2-15) to correspond value to enable this function.
2. Electric lock input (X20) invalid, elevator will enter parking state; cannot set auto start/stop function.
3. In elevator auto stop time and elevator need to run temporarily, turn the electric lock to invalid and restore to valid, elevator will run. After the running, operate the electric lock in same procedures, elevator will re-enter lock mode, until reach auto-start time, then it starts running again.

## 6.7. Fireman Operation Function Setup

Controller has three kinds of fireman operation mode; fireman mode (F1-23) can be set as “0, 1, and 2”;

**0; Normal fireman mode;** When fireman input is valid, elevator lands to the nearest floor but doesn't open door, then it returns to the fireman floor(F0-02), it opens door and stops, meanwhile it enters into the fireman mode, elevator can run in fireman standard.

**1; Fire emergency stop mode;** When fireman input is valid, elevator lands to the nearest floor but doesn't open door, then it returns to the fireman floor (F0-02), it opens door and stops. Meanwhile elevator stops running, until fireman input is eliminated.

**2; Fireman control mode;** It includes two steps, step 1 is fire emergency return, and step 2 is fireman operation. Only after elevator returns to the fireman floor could step 2 be operated.

1) Fireman input switch has two states (ON/OFF); it is connected to BY1-4 of hall call board. Fireman operation switch has three states (ON/START/OFF), ON is connected to fireman input (by-pass input) on COP, START is connected to the door close input in parallel (For fireman to close door, when fireman turns the key to the START position, point ON is still valid, after releasing switch will automatically return to ON.)

Step 1; Fireman input X12 is valid, if elevator is running, it will cancel all car call and landing call and stop at the nearest floor but doesn't open door and then return to the fireman floor; if elevator is under stop and door open state, elevator will close door at once and return to the fireman floor. After elevator returns to the fireman floor, it opens door and stop running.

Step 2; Elevator in fire mode, return to fireman floor then stop running; At this time fireman operation running can be activated by fireman operator switch, switch to ON/STAR, elevator will run under fireman operation (Only serve one car call, door open and close follow fireman operation function). After switch to ON/STAR and elevator finished serving fireman operation, if elevator already leave the fireman floor, and switch is turned to OFF, at this time elevator will keep running. Only when elevator returns to the fireman floor again then it will stop running.

2) After elevator enters fire mode, light curtain input will be invalid. Elevator will exit from fire mode only when fireman input switch, fireman operation switch is both in OFF state.

**Note;**

- 1. Fire switch is ON/OFF status switch, connected to X12 of mainboard. Firefight switch has ON/START/OFF 3-status. ON is connected firefight input (non-stop input) of car operation board and START is connected to close door input (for firefighter to close door. If manually turn the key to START position, ON contact will be still valid. After release, firefighter switch will automatically turn back to ON position.)**
- 2. After entering fire mode, light curtain will be invalid.**
- 3. After fire input switch and firefight switch are turned off, elevator can exit fire mode.**

## **6.8. Rear Door Control Setup**

### **6.8.1 Different Mode Selection**

On the same floor, both front/rear doors can be opened; there are different modes (0-n) available based on customer requirements.

Parameters setup for rear door mode is F1-22.

**n=0;** single door mode.

**n=1;** Rear door mode 1, only one door acts at every floor.

**n=2;** Rear door mode 2, two doors can open on some floors, but they cannot open at the same time, if one door needs to be opened, the other door must be closed first. (Two sets of COPs are needed for both front and rear door.)

**n=3;** Rear door mode 3, two doors can open at some floors, after landing on these floors, two doors open at the same time. (Only one set of COP is needed, HOP calling address is same for both doors.)

**n=4;** Rear door mode 4, two doors can open at some floors, after landing on these floors, two doors open at the same time. (Two sets of COPs are needed for both front and rear door.)

**n=5;** Rear door mode 5, two doors can act at some floors, when elevator runs to such floors, door will open as per requirement, for example; front/rear door will open on front/back car call and landing call. Both doors will open on both sides car/landing call. (Two sets of COPs are needed for both front and rear door.)

According to the rear door mode, HOP address setting and COP wiring are different too;

### 1. HOP address setting

- 1) When rear door mode on controller is set as **0, 1, 3**, HOP address is same as usual;
- 2) When rear door mode on controller is set as **2,4,5**, HOP address is set as below;
  - a) **1~32** is the absolute floor number at front door side;
 

**1** is the bottom floor, **2** is second to bottom floor, maximum number is **32**, total **32** floors.
  - b) **33~64** is absolute floor number at rear door side;
 

**33** is the bottom floor, **34** is second to bottom floor, maximum number is **64**, total **32** floors.
  - c) If there is only one door on some floors, then the HOP address for the other door is empty.

**Example 1;** Elevator has one basement floor with both front and rear doors, on this floor HOP address is 1 for front door and 33 for rear door.

**Example 2;** Elevator has one basement floor with only front door, and one ground floor with both front and rear doors, on the basement floor HOP address is 1 for front door and empty for rear door. On the ground floor HOP address is 2 for front door and 34 for rear door.

### 2. C.O.P button wiring;

- 1) When rear door mode on controller is set as **0, 1, 3**; **1~N** floor buttons are connected to the COP terminal as usual.
- 2) When rear door mode on controller is set as **2, 4, 5**; set total floor no. **N**, then the **1~N** car call ports correspond to **1~N** floor car call buttons at front door, **1** is the bottom floor, **N** is the top floor. **N+1~2N** floor car call ports correspond to the **1~N** floor car call buttons at rear door, **N+1** is the bottom floor, **2N** is the top floor.

**For example;** Elevator has 6 floors (1~6), no basement, 3<sup>rd</sup> floor has double entrance; other floors have only front entrance. Then car call buttons **1~6** at front door should be connected to **1~6** car call ports, car call button **3** at rear door should be connected to **N+3=6+3=9** car call port.



When rear door mode is **1, 2, 3, 4, 5**, need to install two sets of door open/close buttons, this is to open front and rear door separately in inspection running.



If rear door mode is **1**, and there is one set of door open/close buttons, please set parameter **FU18** to "ON". In other mode, if there is only one set of door open and close buttons, in inspection running, only front door can be opened by door open button, rear door cannot be opened by the button.

### 6.8.2 Rear Door Condition Setup

Front door setting parameter (F4-04) and rear door setting parameter (F4-05) are required to set front or rear door open on certain floors. In single door mode, these two parameters are invalid. In rear door mode, if set F4-04 to "ON"

for some floors, front door can open on these floors, if set F4-04 to “OFF”, front door cannot open on these floors. This is same for rear door setup. Please set both doors condition based on actual situation to avoid door open mistake.

### 6.9. Input Type Setup

Input type on main control board (F3-00) and COP board (F3-01) can be changed based on actual ON/OFF state. When switch is at valid position/state and switch is closed, then its input type is ON. When switch is at valid position/state and switch is open, then its input type is OFF. Input type setup on main control board and COP board can be seen below in Chart 6.3

Chart 6.3 Input Type Setup

Name	Port	Position	Definition	Parameters	Default Input Level	Output Switch Default State	Indicator Default State
Main Control Board F3-00	X0	J3-8	Inspection Input	F3-00-00	ON	OPEN	OFF
	X1	J3-7	Run up Input	F3-00-01	ON	OPEN	OFF
	X2	J3-6	Run Down Input	F3-00-02	ON	OPEN	OFF
	X3	J3-5	Top Terminal 2 Input	F3-00-03	OFF	CLOSE	ON
	X4	J3-4	Bottom Terminal 2 Input	F3-00-04	OFF	CLOSE	ON
	X5	J3-3	▲ Top limit/Spared/Maintenace mode input	F3-00-05	ON	CLOSE	ON
	X6	J3-2	▲ Bottom limit/Door bypass input	F3-00-06	ON	CLOSE	ON
Main Control Board F3-00	X7	J3-1	Top Terminal 1 Input	F3-00-07	OFF	CLOSE	ON
	X8	J2-8	Bottom Terminal 1 Input	F3-00-08	OFF	CLOSE	ON
	X9	J2-7	Up Leveling Input	F3-00-09	ON	OPEN	OFF
	X10	J2-6	Down Leveling Input	F3-00-10	ON	OPEN	OFF
	X11	J2-5	star-sealed contactor feedback/brake contactor feedback 2(for electric star-sealed)	F3-00-11	OFF	CLOSE	OFF
	X12	J2-4	Fire input	F3-00-12	ON	OPEN	OFF
	X13	J2-3	Brake contactor 1 feedback (communication type brake power board)	F3-00-13	ON	OPEN	OFF
	X14	J2-2	Door Interlock Input	F3-00-14	ON	OPEN	OFF
	X15	J2-1	Left Brake Feedback	F3-00-15	OFF	CLOSE	OFF
	X16	J1-10	Running contactor feedback Input/STO feedback	F3-00-16	OFF	CLOSE	OFF
	X17	J1-9	Brake Contactor Feedback Input	F3-00-17	ON	OPEN	OFF
	X18	J1-8	ARD function Input	F3-00-18	ON	OPEN	OFF
	X19	J1-7	Light load input/Spared/Right brake feedback	F3-00-19	OFF	CLOSE	OFF
	X20	J1-6	Electric Lock Input	F3-00-20	ON	OPEN	OFF
	X21	J1-5	Heat Sensor Input/Earthquake input	F3-00-21	OFF	OPEN	OFF
	X22	J1-4	Re-leveling condition Input	F3-00-22	ON	OPEN	OFF
	X23	J1-3	Re-leveling sensor Input	F3-00-23	ON	OPEN	OFF
	X24	J1-2	Full load input/Multi-function input/UCMP fault input for geared motor	F3-00-24	ON	OPEN	OFF
	X25	J1-1	Overload input/multi-function input	F3-00-25	ON	OPEN	OFF
	X29+	J7-5	Emergency Stop Input +	F3-00-29	ON	OPEN	OFF
	X29-	J7-4	Emergency Stop Input -				
	X30+	J7-3	Door Interlock Input +	F3-00-30	ON	OPEN	OFF
	X30-	J7-1	Door Interlock Input -				
	X31+	J7-2	Landing Door short detection 1+	F3-00-31	ON	OPEN	OFF
X31-	J7-1	Landing Door short detection 1-					
X32+	J5-4	Landing Door short detection 2+	F4-06-04	ON	OPEN	OFF	
X32-	J7-1	Landing Door short detection 2-					

Chart 6.3 Input Type Setup (Cont'd)

Name	Port	Position	Definition	Parameters	Default Input Level	Output Switch Default State	Indicator Default State
Car Control Board F3-01	KMV1	J9-2	Door open limit 1 Input	F3-01-07	OFF	CLOSE	
	GMV1	J9-3	Door close limit 1 Input	F3-01-06	OFF	CLOSE	
	KMV2	J10-5	Door open limit 2 Input	F3-01-05	OFF	CLOSE	
	GMV2	J10-6	Door close limit 2 Input	F3-01-04	OFF	CLOSE	
	KAB1	J9-4	Safety Plate 1 Input	F3-01-18	OFF	CLOSE	
	KAB2	J9-7	Safety Plate 2 Input	F3-01-17	OFF	CLOSE	
	CZ	J9-5	Over load Input	F3-01-15	ON	OPEN	
	MZ	J9-6	Full load Input	F3-01-13	ON	OPEN	
	QZ	J9-8	Light load Input	F3-01-14	ON	OPEN	
	KZ (50%)	J9-9	50% Load Input	N/A	ON	OPEN	
	SZH	J9-10	Attendant Input	F3-01-10	ON	OPEN	
	SZY	J10-1	Special Use Input	N/A	ON	OPEN	
	SZS	J10-2	Drive by-pass Input	N/A	ON	OPEN	
	ZHS	J10-3	Attendant Up	F3-01-19	ON	OPEN	
ZHX	J10-4	Attendant Down	F3-01-20	ON	OPEN		
Car Top board	LSB1	J2-5	Light curtain 1 input	F3-01-21	ON	OPEN	
	LSB2	J2-9	Light curtain 2 input	F3-01-22	ON	OPEN	

▲ Note ; If the top/bottom limit circuit is closed in normal state, default input level shows "ON".  
If the top/bottom limit circuit is open in normal state, default input level shows "OFF".

## 6.10. Service Floor Setup

Non-stop floors in the system can be set through F4-00 and F4-01. For the floors that elevator can land, set "ON", for the floors that elevator cannot land, set "OFF". After setting F4-00, F4-01, elevator cannot land to the set floors in any case. Based on this function (refer to the function selection Chart), non-stop on certain floor in set time function is available too. Between the non-stop beginning time (F2-14/15) and ending time (F2-16/17), if elevator cannot land on some floors, please set the non-stop floors by setting F4-02 and F4-03 "OFF".

## 6.11. Weighing Device Setup

When using SJT-151 or SJT-201 weighing device, load detection is available through communication with main control board on CAN BUS. See below for setup procedures;

1. Enable weighing device F1-29=1, F9-11=1;
2. Perform light load and full load self-learning procedures;
3. According to the compensation condition, adjust the compensation coefficient F9-00.
4. For elevator with no compensation chain, adjust F1-18 based on actual condition on top and bottom floor;
  - a) Adjust the simulated load compensation gain in inverter until elevator runs down from top floor with no sliding;
  - b) Move the empty elevator to bottom floor, increase load compensation adjustment parameter until elevator runs up from bottom floor with no sliding;
  - c) The adjustment range for this parameter should be 0-12.

## 6.12. Duplex Control

Controller has internal integrated duplex module, two elevators are connected through CAN1 in parallel, corresponded parameters need to be set to achieve duplex control.

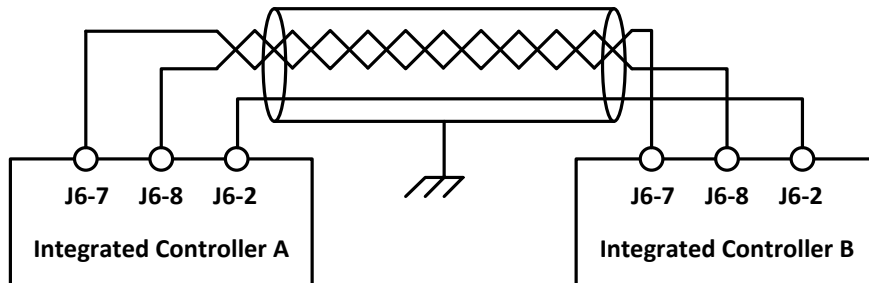

FIGURE 6.9 CONNECTION FOR DUPLEX CONTROL

Setup procedures;

1. Enable duplex control, F1-25=1
2. Set duplex elevator number F1-24, elevator A is set to 0, elevator B is set to 1.
3. Both elevators must have same fireman floor. (Otherwise call registers will be mixed up)
4. Call address should be set the same with single elevator.

After setup please save the parameters, reset the power and updating the communication address.

## 6.13. Group Control

Main control board and group control board are connected through CAN1 port. (See group control board manual), corresponded parameters need to be set to achieve group control.

Setup procedures;

1. Enable group control, F1-26=1;
2. Set elevator number in F1-24, the number should be 0-7 for elevator A-H.
3. All elevators must have same fireman floor. (Otherwise call registers will be mixed up)
4. Call address should be set the same as single elevator.

After setup please save the parameters, reset the power and updating the communication address.

## 6.14. Leveling Adjustment Setup

After elevator landing, if elevator speed curve has no problem (i.e. there is no sudden stop and overrun leveling zone at elevator landing) and elevator runs outside leveling zone (it stops higher than leveling zone in up-running, lower than leveling zone in down-running), need to decrease leveling adjustment parameter F1-17 (default 50); if elevator cannot reach leveling position(it stops lower in up running, higher in down running), increase leveling adjustment parameter F1-17, general range for adjustment is 40-60, if the adjustment is big, please adjust driving parameter PI, or speed curve shape (F1-10~F1-15).

## 6.15. Floor Indication Setup

In parameter F0-05~F0-69, we can set third bit display, first two bits can be figure, characters or “- “, third bit can only be the following capital characters; ABCDEFGHIJKLMNO. If only need two bits, set the first two bits only and third bit is empty. (Third bit indication should be supported by the HOP board, otherwise it cannot display normally.)

## 6.16. Special Function Selection

To meet certain special requirements from customers, this control system has included some customized functions (F4-06 & F4-07).

Chart 6.4 Special Function List

Number	Instruction
F4-06-00	After elevator stops, based on current floor, if there is no landing/car call ahead of the current floor in previous running direction, system will cancel all the car calls.
F4-06-01	ON; the monitor input menu of the main board indicates that the signal is valid or invalid, which is the signal state processed through the input type. The default value is OFF.
F4-06-02	ON; Levels the car first to evacuate passengers on the nearest floor in the first place then return to base floor; OFF; Elevator won't level the car, but directly return to base floor and then open door and evacuate passengers.
F4-06-03	ON; Shielded communication interference ER29 fault.
F4-06-04	ON; The main board adds new high voltage input signal X32, which is used for short connection detection of rear hall-door and car-door. It is suitable for the main board of MU-V61 VM2. The default value is OFF. SJT-ZPC-V2A (VM1) type safety circuit boards must be used.
F4-06-05	ON; Elevator disable cabin overload signal, this is used in elevator 125% load test (This parameter cannot be saved. After power failure, it will resume OFF.); OFF; Overload signal enable.
F4-06-06	ON; When the elevator cannot open door in current floor (Open Door fault in controller), it will automatically go to the next floor and open door.
F4-06-07	ON; Floor number display change after elevator enter landing zone; OFF; Floor number display change after elevator change speed.
F4-06-08	ON; When elevator stops in inspection mode, brake will close after receiving zero speed signals to reduce impact.
F4-06-09	ON; Elevator can cancel registered car call while running (If all registered call canceled, elevator stop in nearby floor)
F4-06-10	Inner test. ON; Force to use the curves without line segments.
F4-06-11	ON; Cancel emergency stop contactor in the Control cabinet.
F4-06-12	The high voltage entrance of the hall door and the car door are separately detected, x30 is the hall door, and the X31 is the car door.
F4-06-13	ON; In the control cabinet, the door interlock contactor is cancelled, the high voltage detection is used as the state detection of the door lock loop, and the detection and fault of the feedback of the door interlock contactor are cancelled.
F4-06-14	ON; Enable elevator function for disabled people. OFF; Disable elevator function for disabled people.
F4-06-15	ON; In Fire mode when elevator leaves fire floor then disables fire linkage output.
F4-06-16	ON; When door lock is closed, door close limit must be valid too, except inspection mode. OFF; Door lock state is not related to door close limit. Forced detection of bypass operation cannot be cancelled even if it is set to OFF.
F4-06-17	Only for internal test. Remain the default OFF state.
F4-06-18	ON; In two-door mode, elevator only installs one set of door open& close buttons. OFF; In two-door mode, elevator installs two sets of door open & close buttons.
F4-06-19	ON; Enable re-levelling with door open function. (Need to use SJT-ZPC-V2A re-levelling control board) OFF; Disable re-levelling with door open function.
F4-06-20	ON; Enable door open in advance function. (Need to use SJT-ZPC-V2A re-levelling control board) OFF; Disable door open in advance function.
F4-06-21	ON; In inspection mode, door cannot open outside levelling zone. OFF; In inspection mode, door can open at any position.
F4-06-22	<b>Previous versions of IECS_7122:</b> ON; 3-phase 380V 50Hz power supply (with back-up generator) OFF; Battery power supply (disable DC-BUS under voltage fault) <b>IECS_7122 and later versions:</b> ON; increase the communication of bottom pit inspection board, slow down and up down in the bottom pit in inspection mode, so that If it does not connect with the bottom pit, it will be forced to inspection state, and cannot resume the normal operation.
F4-06-23	ON; Use SJT-300/201 weighing device through CAN BUS; OFF; Use SJT-151 weighing device through RS485.

Chart 6.4 Special Function List (Cont'd)

Number	Instruction
F4-06-24	ON; secondary-terminal switch is adopted for elevator speed <2m/s (it is generally used in 1.75m/s elevator for two steps forced deceleration.) OFF; Secondary-terminal switch is not adopted for elevator speed below 2m/s.
F4-06-25	ON; In inspection mode door open/close switch in car is <b>invalid</b> ; OFF; In inspection mode door open/close switch in car is <b>valid</b> ;
F4-06-26	ON; Close light-load anti-nuisance function, passengers can input more than three car calls in light-load mode.
F4-06-27	ON; Change direction after zero speed. OFF; Change direction after brake is off.
F4-06-28	ON; Use light curtains/safety plates separately, the light curtain signals can be shield when the light curtains adhesion or in fire mode for more than 2 minutes. When this function is enabled, the light curtain and the touch plate signal of the original car are transformed into a pure light curtain signal. The driver mode up and down direction of the original car are transformed into a safe touch plate signal of the front and rear door. After shielding the light curtain, it will only detect the touch plate signal after the light curtain adhesion.
F4-06-29	ON; Motor operation & internal star-sealed contactor are used separately, Y5 as Internal star-sealed contactor output control; OFF; Operation contactor has internal short-circuit function.
F4-06-30	ON; Integrated controller LED has reverse display. This is used for G-series cabinet in roomless elevator (where control board is placed reversely) OFF; Integrated controller LED has normal display. (Default Settings)
F4-06-31	ON; Manual door function, opening and closing operation is controlled by the passengers manually, and the system no longer outputs the opening and closing signal. (Please refers to detail in Appendix 21 Manual door solution)
F4-07-00	ON; When ARD function is active, system will open brake for 1s (when sliding speed >0.1m/s, brake will close again), it will then find the heavy load direction based on the sliding direction, use battery to land the cabin on heavy load direction and reduce leveling energy cost.
F4-07-01	ON; Enable elevator data recorder. Together with PC debugging software, after-sales/service team can provide fault diagnosis.
F4-07-02	ON; Disable top/bottom limit signal, use another mechanism to detect limit signal; a. Top terminal/down door zone valid + up door zone invalid = Top limit; b. Bottom terminal/up door zone valid + down door zone invalid = bottom limit.
F4-07-03	ON; Enable serial connected electric lock.
*F4-07-04	ON; elevator door-open and hold function. (including base station floor, internal selection and external call, then automatically close the door.)
F4-07-05	ON; Enable serial connected fire-linkage signal.
F4-07-06	ON; the input type of serial fire-linkage signal is reversed.
F4-07-07	ON; Enforce the hitting ceiling and touching ground protection. If car speed inside leveling zone is still faster than rescue speed, then the car will be forced to stop in leveling zone by leveling zone correction.
F4-07-08	ON; Main board X14 input is used as over load signal input.
F4-07-09	ON; Main board X13 input is used as full load signal input.
F4-07-10	Previous versions of IECS_7122: Main board X19 input is used as light load signal input. Note; The brake feedback function must be disabled. (When brake feedback is forced to be enabled, above function is invalid) IECS_7122 and later versions: ON; When the elevator is running in parallel mode and ARD is enable, the elevator will return to the base station in turn. The A ladder will return first and then the B ladder will return.

Chart 6.4 Special Function List (Cont'd)

Number	Instruction
F4-07-11	<p>Previous versions of IECS_7122: Use for selecting if there is unintended car movement protection device or not. On; Yes, Y11 will output signal to act safety brake.</p> <p>IECS_7122 and later versions: ON; When the elevator is running in parallel mode and ARD is enable, after the elevators have returned to the base station in turn, the elevators set to ON will restore normal service. (If the safety brake trigger signal output of the original Y11 relay is required, please set the F3-08 Y11 output function to 18.)</p> <p><b>Note; If the safety brake of the Y11 relay triggers the signal output correctly in the event of accidental movement protection in the car, and the special function of the F4-07-26 roller protection function should be opened in advance.</b></p>
F4-07-12	ON; In Auto(normal) mode, car stops three times answering car call without light-curtain action, the car call registration will be cleared.
F4-07-13	ON; Enable door-squeezing function to avoid door lock circuits open frequently in auto running mode which is caused by door operator lacking self-locking force.
F4-07-14	ON; Modular integrated controller, increasing modular roof communication.
F4-07-15	On; During self-rescue leveling in emergency and self-save leveling outside door zone, the beeper on the COP keep alarming (the interval is 1 second) while the car is moving.
F4-07-16	On; The elevator can run between an ultra-short floor spacing (less than 80cm& more than 30cm) .
*F4-07-17	<p>Previous versions of IECS_7122: ON; In UPS running mode, elevator will arrive into leveling zone, open the door, close the Y11 relay in 30 seconds, and cut off the UPS circuit to avoid a deep discharge of the UPS battery pack. (This function cannot be used simultaneously with F4-07-06 or F4-07-11.)</p> <p>IECS_7122 and later versions: ON; Enable the VIP mode, receive the 63 floor up call or down call of the calling board to enter the VIP recall mode. (If the UPS outage signal output of the original Y11 relay is required, please set the F3-08 Y11 output function to 17.)</p>
F4-07-18	ON; The car waits at homing floor with door open.
F4-07-19	ON; In UPS running mode, the elevator will return to homing floor directly. While ON, F4-07-00 and F4-07-25 will be ineffective.
F4-07-20	<p>ON:Enable TIM Stop Floor function. Stop floor time set1 Start time; F2-18 &amp; 19; End time; F2-20 &amp; 21 TIM stop floor time set1 corresponds Set Stop Floor parameter is; F4-00 Set Stop Floor1, F4-01 Set Stop Floor2. Stop floor time set2 Start time; F2-14&amp;15; End time; F2-16 &amp; 17(multiplexing start time/stop time setting). TIM stop floor time set2 corresponds Set Stop Floor parameter is:F4-02 Set Stop Floor1, F4-03 Set Stop Floor2.</p>
F4-07-21	ON; With one and only one door zone signal, the elevator will still level while it turns from inspection to auto or from error to normal or runs in ARD mode. It will avoid that the car door vane cannot drive the hall door when it is too short.
F4-07-22	On; disable the car arrival-bell to avoid disturbing during 22:00~7:00am.
*F4-07-23	ON; When error occurs in up running except top floor or down running except bottom floor, elevator slow down and stop, but not suddenly stop.
F4-07-24	ON; Elevator return to homing floor to proofreading level number when power on for the first time.
*F4-07-25	ON; Before self-rescue, open brake and keep the elevator at zero speed and lock the direction of torque, then self-rescue to opposite direction of the torque. While ON, F4-07-00 is ineffective.
F4-07-26	ON; Enable slide protection function; OFF; Disable slide protection function.
F4-07-27	ON; Enable brake force self-test function. Automatically start at 2:00AM or manually start by modify F4-07-30.

Chart 6.4 Special Function List (Cont'd)

Number	Instruction
*F4-07-28	ON; Add a new running mode. If X24 is effective in inspection mode, the car will automatically stop at 2 meters under door zone of top floor.
F4-07-29	ON; Levelling adjustment can be adjusted in layers, add adjustment value of 1~64 layer in parameters, all the Default values are 50mm. (The new adjustment method can be adjusted through the combination buttons in the car.
*F4-07-30	Each time turn to ON from OFF, act brake force self-test once. Keep ON will be ineffective.
F4-07-31	ON; Enter a test mode, that elevator will continuous run without door open.

**Note; Please notice the function number with "\*" and distinguish software version. (U5-00)**

**Note; Please notice the function number with "\*" and distinguish software version. (U5-00)**

## 6.17. Motor Parameters Speed Setup

First, please set the motor parameters based on actual machine.

F5-00; motor type. 0; synchronous outer rotor machine; 1; asynchronous machine, 2; synchronous inner rotor machine.

Please make sure the machine type is set correctly, as system will perform motor auto-tuning and vector control based on motor type.

Also, please input following motor parameters based on the machine nameplate or user manual to ensure the accuracy of system generated motor digital model and vector control coupling.

1. F5-01; Motor poles
2. F5-02; Motor rated frequency
3. F5-03; Motor rated power
4. F5-04; Motor rated speed (RPM)
5. F5-05; Motor back-EMF (this parameter is only valid for asynchronous machine)
6. F5-06; Motor phase inductance (this parameter can be acquired from motor auto-tuning)
7. F5-07; Motor phase resistance (this parameter can be acquired from motor auto-tuning)
8. F5-08; Motor rated current
9. F5-09; No-load current (this parameter is only valid for asynchronous machine, it can be acquired from motor self-learning)
10. F5-10; Motor rated Slip (this parameter is only valid for asynchronous machine)

**Note; 1. Besides above, when some parameters are not accurate, please perform motor parameter auto-tuning.**

**2. For the drive versions above 7107, parameter auto-tuning is not necessary.**

## 6.18. Elevator Running Speed Setup

Elevator rated speed (F1-00) and motor rated speed (RPM) (F1-01) are used to calculate the ratio between elevator rated running speed and motor RPM. Also, with encoder pulse number per cycle (F1-03), we can get the relationship between each pulse and traveling distance in hoistway, and this achieves the distance detection of elevator running. Therefore, changing F1-00, F1-01 will only change their ratio, but not elevator actual running speed.

When F1-03 for hoistway counting is from inner pulse source, pulse number in one cycle (F1-03) = pulse number of motor encoder (F8-00) / PG frequency division ratio (F8-01). Rated speed of traction machine (F1-01) = Motor rated speed (F5-04).

If F1-03 for hoistway counting is from outer pulse source (i.e. speed limiter encoder, must adopt special PG card), F1-03 should be set as pulse number in one cycle from outer pulse source, rated speed of traction machine (F1-01) = Outer pulse source speed (i.e. speed limiter speed).

Speed given instruction can be seen below in Figure 6.10.

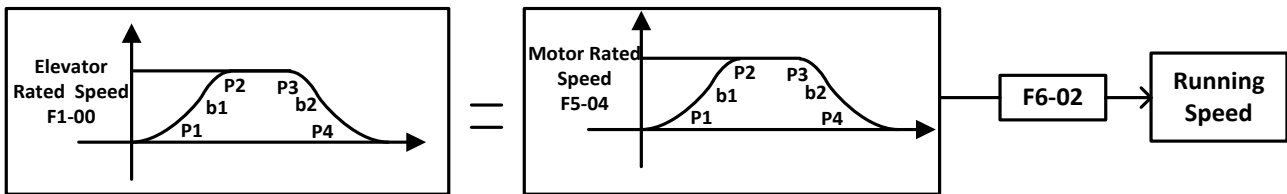

FIGURE 6.10 SPEED GIVEN INSTRUCTION

If need to reduce the elevator actual speed, please change the value of speed ratio (F6-02), when F6-02=100%, elevator runs in rated speed; reduce F6-02 elevator actual speed will decrease in corresponded ratio.

## 6.19. Speed Control Setup (PI Adjustment)

### 6.19.1 Speed Control Setup with Single PI Adjustment

For speed control under vector control, there are two ways, F7-00; when multi-section PI enable is set 0, PI does not change with speed given change. Instead, it is a fixed value for the whole elevator speed range, which simplifies setup procedures.

This is the most used method; the flow diagram can be seen below in Figure 6.11.

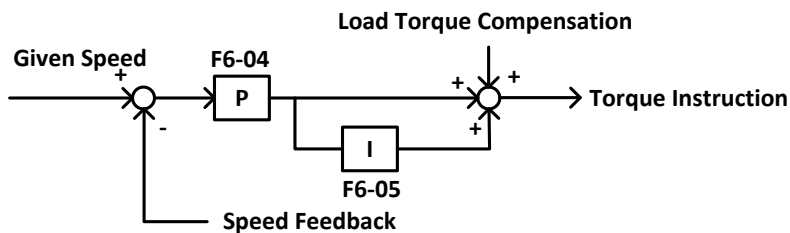

FIGURE 6.11 SPEED ADJUSTMENTS 1

### 6.19.2 Speed control Setup with Multi-Section PI Adjustment

For speed control under vector control, F7-00; multi-section PI enable is set 1, speed control function can be performed by PI changed in multi-section. In this control mechanism, parameters in F6-04 and F6-05 will not take effect all the time, instead, 4 groups of PI value F7-05~F7-12 are used to perform speed control.

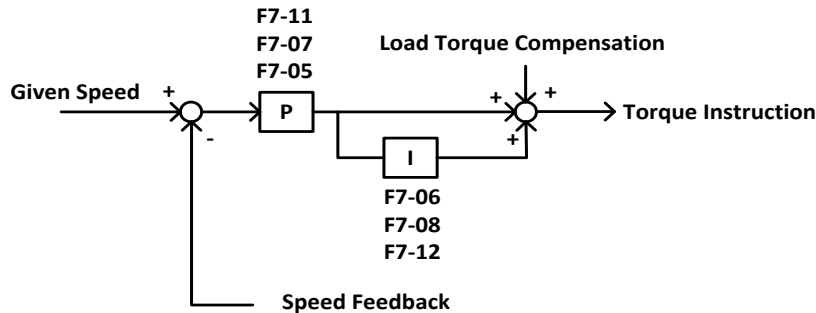

FIGURE 6.12 SPEED ADJUSTMENTS 2

F7-05, F7-06; Group 1 PI; it is generally adopted in low speed period at motor start.

F7-07, F7-08; Group 2 PI; it is generally adopted in middle speed section at acceleration period or steady-speed section at low speed period.

F7-11, F7-12; Group 3 PI; it is generally adopted in deceleration period.

Switching frequency for the above groups of PI parameter are set in F7-01~F7-04; frequency setting of PI effective range.

Group 1 PI effective range;

When motor starts from zero speed or in acceleration period, if the current frequency given is smaller than F7-01, system will adopt F7-05, F7-06 of group 1 PI to adjust the speed. To enable elevator quick stable at zero speed when brake release and follow the speed curve quickly in initial acceleration, F7-05 and F7-06 can be set slight bigger.

Group 2 PI effective range;

After motor starts, when speed (acceleration) is larger than the set frequency in F7-01 and smaller than F7-02, system will adopt F7-07, F7-08 of group 2 PI to adjust the speed. When motor running speed is larger than the set frequency in F7-02, system will adopt F6-04 and F6-05.

Group 3 PI effective range;

When motor speed is smaller than the set frequency in F7-03 (deceleration), system will adopt F7-11, F7-12 of group 3 PI to adjust the speed. This group of PI parameters is used for adjustment in deceleration to stop period. If F7-03 is 0, system will adopt the last group of PI parameters before deceleration.

For different groups of PI effective range please see Figure 6.13 below.

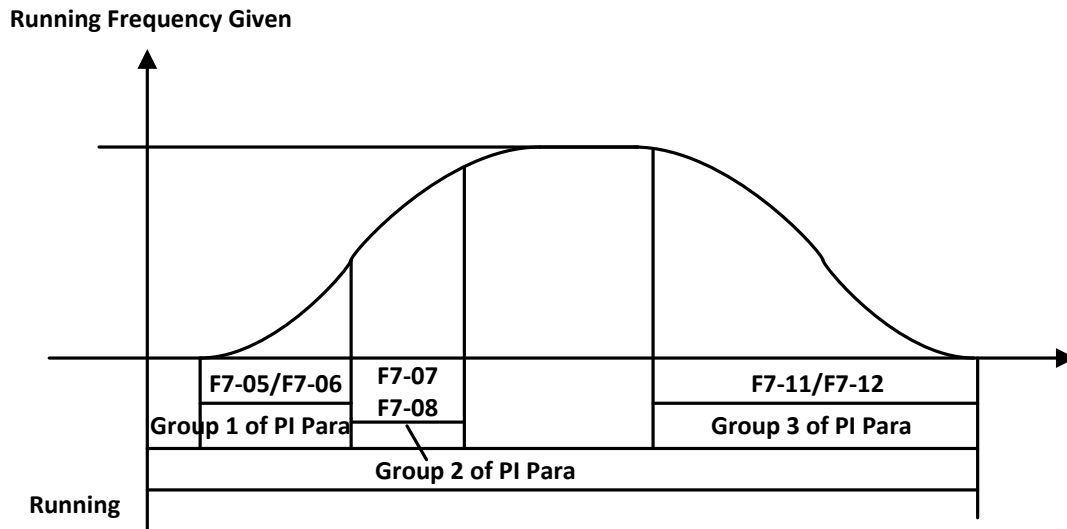

FIGURE 6.13 EFFECTIVE RANGES FOR DIFFERENT GROUPS OF PI

## 6.20. Load-Compensation Torque Output Setup

Parameters related to load compensation torque output control;

1. The parameters related when using of weighing device;
  - 1) F1-29; Weighing device enable (1; enable, 0; disable)
  - 2) U6-03; weighing value, the current load situation
  - 3) F1-18; weighing adjustment, adjust the compensation according to floor number, it is suitable for elevator without compensation chain.
2. Load simulative input, input range+10V~-10V or 0V~+10V, this input cannot be changed.
3. Load compensation source selection F9-13,
  - 0; Internal serial signal, it can only be used with the weighing device;
  - 1; External simulative input +10V~-10V;
  - 2; External simulative input 0V~+10V.
4. Maximum torque compensation F9-00; if set to 60%, the maximum output torque compensation at full load will be 60% of the rated torque.
5. Torque control output enable F9-11; if set to "1", system will output torque based on the source of F9-13 and multiply by F9-00; if set to "0", load compensation is disabled.

Output control diagram of load compensation torque can be seen below in Figure 6.14.

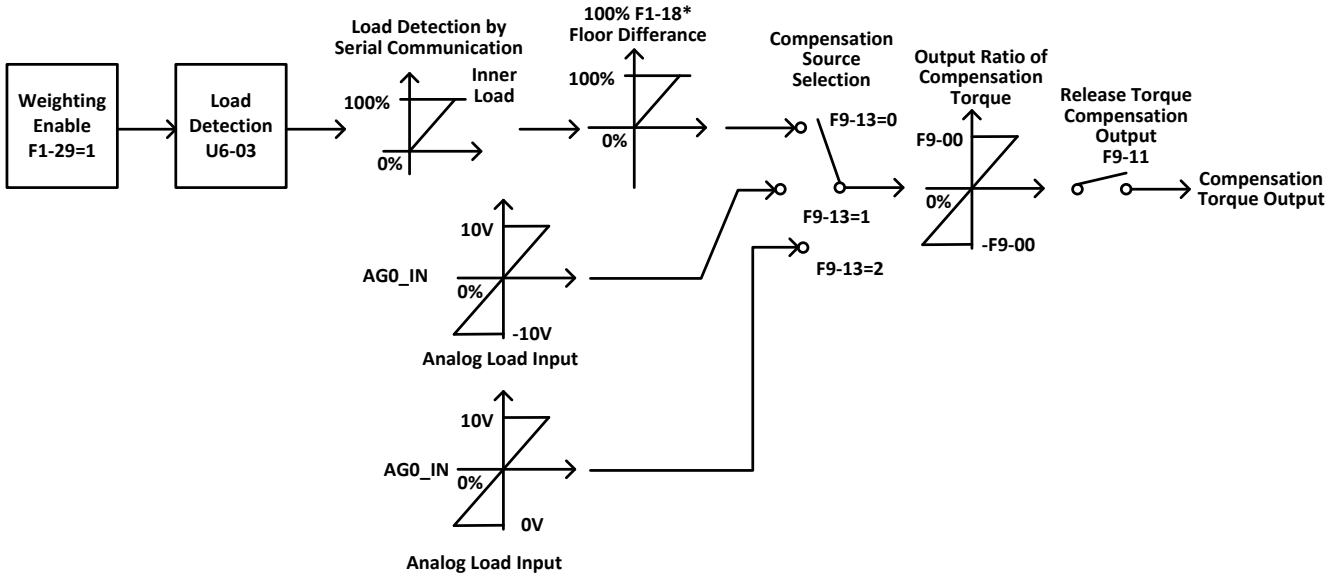

FIGURE 6.14 LOAD COMPENSATION TORQUE OUTPUT CONTROL

6. In synchronous machine control, as there is no compensation chain for low building, weighing device can only measure the load in cabin and cannot detect the rope weight variation on different floor. In this case load compensation adjustment (F1-18) need to be used.

Adjustment Procedures;

- 1) Perform no-load, full-load learning;
- 2) Run the no-load elevator to top floor;
- 3) Adjust simulative load compensation gain in inverter until elevator does not slide when runs down from top floor.
- 4) Run the no-load elevator to bottom floor, increase the load compensation adjustment parameter (F1-18) until elevator does not slide when runs up from bottom floor.

6.21. Encoder Parameters Setup

Set F8-00 based on encoder pulse number. Encoder pulse usages can be seen below in Figure 6.15.

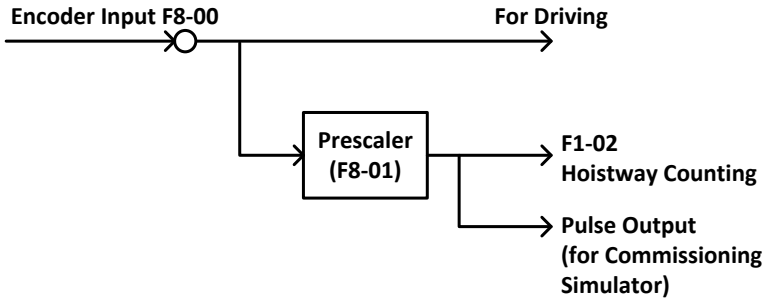

FIGURE 6.15 ENCODER PULSE USAGES

## 6.22. Start without Load Compensation Setup

When using V9 series integrated controller with Sine/Cosine PG card, it is possible to achieve comfort start without load compensation by proper setup in FA group parameters. (It means elevator can reach the same effect of load compensation even without weighing device.)

1. Note for starting without load compensation;
  - 1) PG card type, F8-02 is set to "1" (Sine/Cosine PG card)
  - 2) Weighing compensation invalid, confirms F9-11 is set to "0" to disable weighing compensation and enable FA group parameters.
  - 3) Drive software version confirm version is 0005 or above.
2. Adjustment method for elevator starting without load compensation;
  - 1) Principles; As can be seen in Figure 6.16 below, when brake open, based on the position feedback from Sine/Cosine PG card, system can calculate the necessary torque required for motor to remain the steady position under current load, and it gives corresponded torque at once to minimize the traction sheave movement and to achieve comfortable start.

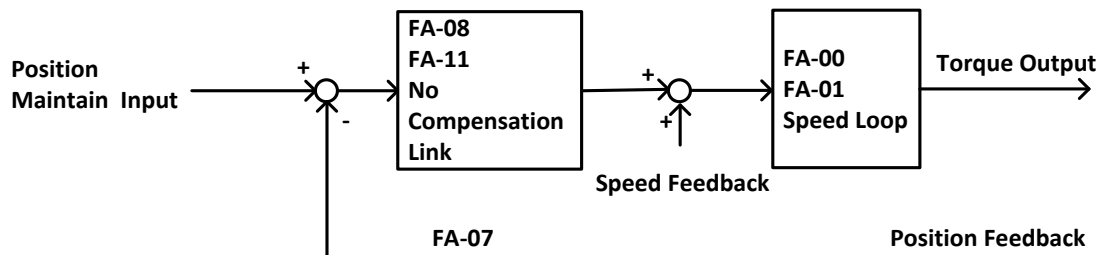

FIGURE 6.16 FLOWCHART FOR ELEVATOR STARTING WITHOUT LOAD COMPENSATION

- 2) Parameters; Parameters related to function can be seen below in chart 6.5.

Chart 6.5 Elevator start without load compensation parameters list

Para No.	Display	Factory Setting	Fast Brake Recommendation	Slow Brake Recommendation
FA-00	StratKP	30	KEEP	KEEP
FA -01	StratKI	750	KEEP	KEEP
FA-04	ZeroKeepKP	180	KEEP	KEEP
FA-05	ZeroKeepKI	550	KEEP	KEEP
FA -08	PLKP1	2500	3300	2500
FA -09	PLTime	900	700	KEEP
FA -11	PLKP2	800	KEEP	KEEP
FA -12	PLKPMOD	125	KEEP	KEEP
F2-00	Brake ON Time	0.5	0.9	1
F9-00	Max Torq Comp	0	KEEP	KEEP
F9-11	Load Comp Enable	0	0	0

- 3) Adjustment method; Main parameters used are FA-08, FA-09 and FA-11.

FA-09

This parameter is the working time for starting without load compensation after brake opens, it must be set according to the actual brake opening time, if the time is too short, elevator will slip as this action will be over before brake fully opened; Also the value of F2-00 (brake opening time before running) must be 100ms longer than the value of FA-09, so that this action can finish before speed curve start.

### FA-08 and FA-11

Two gain parameters for the starting without load compensation action, these two parameters can be adjusted according to the elevator slipping condition and comfort level, if the slipping is too much please increase the value of FA-08; if the traction machine gets vibration, please reduce this value; during the period of torque keeping, if there is slight slipping or small back-and-forth movement on traction sheave, please increase the value of FA-11, if there is vibration, please reduce this value.



1. **During commissioning, besides the mentioned 3 parameters, other FA group parameters can be kept with factory setting.**



2. **For different versions of program, the name of FA group parameters might be different, but their positions remain the same. As a result, only adjust FA-08, FA-09, FA-11 despite the operator version.**



3. **The setting value of above parameters is just for reference, as the PG card is not same in different job side; please adjust above parameters based on site condition.**



4. **F9-00 is the pre-set torque when the starting without load compensation function is enabled. Generally, there is no need to change its value, please keep it with factory setting (0)**

## 6.23. Remote monitor

Controller supports remote monitor function. Connect controller with assorted WCR remote monitor module, it will use same CAN Bus with COP/HOP communication. Set relative parameters, then remote monitor can be achieved. Parameter setting is as follow,

1. Set Remote monitor enable, F1-27=1;
2. Save parameter.

## 6.24. Elevator maintenance

### 1. Activate Maintenance Reminder Function

- 1) Set FD-04 to non-zero number to activate maintenance reminder function, this number means the maintenance period in days, range from 0~1000. For example, set FD-04=100, which means the maintenance period is 100 days. Thus, this elevator needs to have maintenance at least once in 100 days, otherwise, it cannot operate.
- 2) After set successfully, the time left for maintenance can be checked via monitoring parameter U4-10. For example, U4-10=100 means there are 100 days left for next maintenance, the elevator needs to have maintenance at least once in 100 days, otherwise, it cannot operate.

- 3) When elevator maintenance is overdue, it will run for currently registered floors then stop after leveling and will not run automatically. Hall call and car call can still register, but the elevator does not run.
- 4) When elevator maintenance is overdue, car display and hall display will indicate 'MO'.

### 2. Maintenance Confirmation Operation

- 1) If the maintenance reminder function is on, staffs need to provide services to the elevator on time. During the maintenance, staff needs to operate in the cabinet to inspect and run the elevator up or down once (inspection run for 3s is enough, don't need to run all the way).
- 2) After maintenance, the maintenance reminder will restart. The time left that is shown in U4-10 will automatically reset to the number of FD-04. This operation is valid for both overdue elevator and elevator in maintenance period.

### 3. Special Precaution

- 1) After setting FD-04 to a non-zero number and activating the maintenance reminder function, do not change the system time. Otherwise, it may cause the maintenance reminder to stop the elevator abnormally. If a change in time is necessary, please perform the maintenance confirmation operation once after changing the system time.
- 2) The maintenance function is also valid when the elevator is power off. But if the power off time is too long (more than 10 days), the system's internal power will run out. Then, when the power is next time turned on, the system will stop the elevator straightaway. Maintenance confirmation operation is needed in order to run the elevator normally.

## Chapter 7 Commissioning

### 7.1. Important Reminder

1. Thanks for purchasing our product, please read this manual and related instruction thoroughly before processing with installation, connection (wiring), operation, maintenance and inspection. To avoid any damage/loss of the products or accident to people, please make sure you have sound knowledge of the device and familiar with all safety information/precautions before processing to operate the control system.
2. Before commissioning and running the product, please read the manual carefully and refer to this manual during commissioning and running.
3. Make sure that all the mechanical devices are installed properly beforehand, especially the devices in hoistway (the devices that should be set in the machine room depends on the situation of the machine room).
4. Make sure that the installation and commissioning for the devices, which should be finished before commissioning of the control system, have been completed.
5. Before commissioning, it is necessary to get signature confirmation from a person responsible for mechanical installation and commissioning.
6. Make sure that all the mechanical devices and other devices which are related to the system commissioning are installed and tested properly.
7. Make sure that there are no unsafe factors which could cause injuries and damages to personnel and devices.
8. Commissioning should be carried out by qualified personnel.
9. Site should meet the conditions for commissioning and running.
10. When doing commissioning for both electric and mechanical parts, technicians for both parts should collaborate.
11. If this manual could not meet your requirement, please contact our company at once to acquire help and to avoid accident and loss.
12. Before system commissioning, make sure all the conditions are sufficiently prepared.

### 7.2. Inspections before Power On

After electric system is installed, please check the electric system carefully and pay attention to the following items;

1. Compare with the manual and electric diagram, check if the connections are all correct.

2. Check if there is interference between high voltage part and low voltage part. Use a multi-meter to measure the resistor in different circuit, resistor to earth must be infinity big.
3. Please check if wiring from power supply to the control cabinet and traction machine is correct, this is to avoid damaging the controller after powering on.
4. Check wiring between encoder and controller, coaxial degree of encoder and traction machine shaft, wiring between encoder and traction machine.
  - 1) Check if the enclosure of the controller and motor, cabin, landing door are reliably earthed to ensure the safety to personnel.



Controller enclosure and motor enclosure should be earthed to one point.

- 2) Make sure correct wiring of the terminal block **J1** on control board to avoid any damage to the main control board.



Controller has special digital operator, it should be connected to the socket J232 on main control board by a special cable before commissioning. USB serial communication cable is also available; connect it to the port USB0 on main control board to computer, then do commissioning with special software. (please refer to commissioning software manual)

- 3) Make elevator stop at the middle floor.
- 4) Turn electric lock to position "ON".

### 7.3. Power on and Inspection

#### 7.3.1 Things need to confirm before Power On

1. Confirm all the air switches in control cabinet are open.
2. Confirm mode switch on the controller is at "inspection", emergency stop button is pressed.
3. Confirm inspection switches on car top and cabin are both in "normal" positions.
4. Confirm terminal resistor for bottom HOP is connected
5. Check voltage on the main power supply; :3 phase voltage is  $380\pm 15\%$ VAC, phase-phase voltage difference is smaller than 15VAC, Phase-N voltage is  $220\pm 7\%$ VAC.
6. Confirm the wire specification and main switch capacity match the design requirement.

### 7.3.2 Inspection after Power On

1. Close main power switch Q1, if phase relay KXX green LED on, it means the phase sequence is correct, otherwise red LED on, means phase sequence is incorrect, in this case please switch off the main power switch, exchange any two phases, and repeat the above inspection.
2. Inspect the terminal voltage on transformer **TC1**, the values should be in the range of  $\pm 7\%$  of the indicated value, if voltage exceeds this range, find out the problem and correct it.
3. if the above inspections are normal, then do the following process;
  - a. Switch on F4; Voltage between terminal 100-101 should be  $110 \pm 7\% \text{VAC}$

Voltage between terminal 103-102 should be  $110 \pm 7\% \text{VDC}$

- b. Switch on F5; Voltage between terminal 200-201 should be  $220 \pm 7\% \text{VAC}$
- c. **(Note; Connect digital operator before power on)** After power on, first see if the main menu display is correct on LCD indicator. For example; elevator state, fault state, door lock state, current floor, running speed and else. In this way we can tell if the controller is working properly and whether 24V power supply is normal. Interface on digital operator LCD screen can be seen below in Figure 7.1.

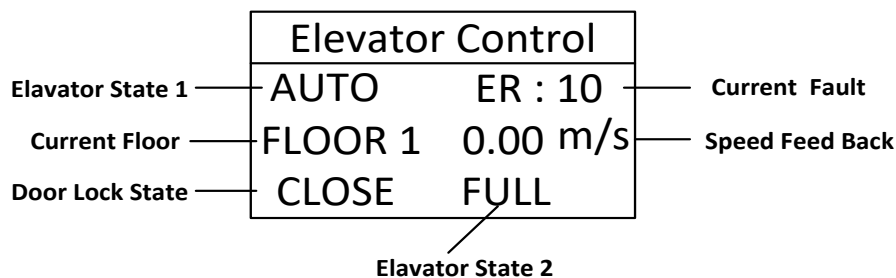

FIGURE 7.1 DIGITAL OPERATOR LCD SCREEN INTERFACE

- d. Terminal voltage of switch power supply unit;

Chart 7.1 Terminal Voltage for switch power supply unit

Terminal	L~ N	24V~ G
Voltage	$220 \pm 7\% \text{VAC}$	$24.0 \pm 0.3 \text{VDC}$

- e. After above inspections, do the following inspections;
  - 1) Check door lock circuit.
  - 2) Check leveling zone signal, top/bottom limit signal.
  - 3) Check electric lock, set the elevator auto-start/off time to "0", set electric lock switch to "ON", LCD screen will then display elevator state as "INSP", if set electric lock switch to "OFF", LCD screen will show "STOP".
  - 4) Check door open/close system, do corresponded adjustment if necessary.

## 7.4. Parameter Setup

It is very important to set Parameters based on actual site condition, as this is the foundation for controller or control system to maximize its performance. For parameter setups please refer to chapter **4-6**. When setting parameters, please pay attention to the following points;

1. Set the motor basic parameters from motor nameplate namely motor parameter 1 content (F5 group). For example, motor type, pole numbers, rated frequency, rated power, rated RPM, rated current, Back-EMF (only for synchronous machine), no-load current (only for asynchronous machine), phase inductance, phase resistance and else. Amount which phase inductance, phase resistance and other parameters that are unknown can be acquired from motor -tuning; if system moment of inertia is unknown, leave it as default.
2. Set encoder parameter correctly (F8 group), for example encoder pulse, PG frequency division coefficient.
3. Set elevator running parameters correctly, such as motor rated RPM, encoder pulse (after frequency division.)
4. Set input type correctly, they should match the actual contactors, relays and hoistway contacts and switches.

## 7.5. Motor Initial Angle Tuning

For synchronous motor, it is necessary to perform motor initial angle tuning. Otherwise the machine cannot run normally, or even sever slip. Therefore, tuning initial angle is very important for synchronous machine. Before proceeding to load run, synchronous machine must first perform initial angle tuning successful and no load running successful. For the tuning procedures, please refer to Figure 7.3.

### 7.5.1. Motor Rotation Tuning

V9 series elevator integrated controller no longer distinguish encoder types. This angle tuning mode requires that the motor is no-load, and the brakes are open.

The preparations before tuning as follows;

1. Synchronous motor (traction machine) must not have any load (don't hang on steel ropes);
2. Short circuit running contactor output Y 9 (J5-10) and COM3 (J5-6) to make it close;
3. Short circuit brake contactor output Y7 (J5-8) and COM3 (J5-6) to make it close and open brake;
4. Short circuit brake contactor 2 output Y6 (J5-7) and COM3 (J5-6) to make it close and open brake;

With digital operator, AutoTuneModeSel (FC-13/FX-20) should be set to 0(0; Rotation tuning; 1; Static tuning). With the motor parameters (F5) and encoder parameters (F8) are set correctly, perform the initial angle rotation tuning as follow figure.

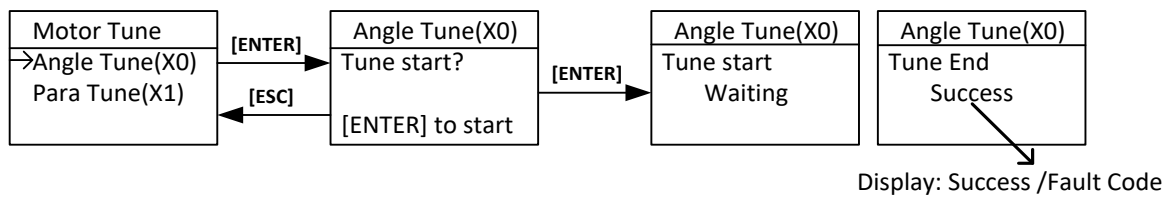

**Figure 7.2 Motor Initial Angle Rotation Tuning**

After pressing “Enter”, tuning starts. At first, Motor will immediately rotate to a certain position, then rotate forward at a certain speed (facing to traction sheave, anticlockwise rotation is forward direction), the speed is depended on motor pole number and initial position. Motor will stop after at most 2 turns and will be rotated again to a certain position to stop for 2 seconds, then tuning stops and the operator display “success”. The whole tuning procedure lasts around 30s.

After tuning successful, perform a trial run according to chapter 4 “4.4 Parameter commissioning in Digital Operator”. Make traction machine accelerate forward from zero speed to rated speed, run it in constant speed for a while and observe the running condition; make motor run in opposite direction in same way.

After trial run with digital operator, please remove the short circuit on “running contactor output” and “brake control output”. Press jog up button on control cabinet to perform inspection running, observe motor running condition; Then press jog down button on control cabinet to perform inspection running, observe motor running condition.

When jog up (down), if the real running direction of cabin is down (up), please set F6-03 to correct it. 0; anticlockwise rotation is down, 1; anticlockwise rotation is up, set based on actual site condition.

After the above trial running is finished, attach the steel rope and run motor with load.

### 7.5.2. Static Tuning Procedures

For this tuning method, tuning can be carried out with steel rope attached, but please make sure the following procedures are finished correctly before tuning;

1. Wiring in control cabinet is completely correct, and system under inspection state;
2. Running parameter (F1), motor parameter (F5) and encoder parameter (F8) are set correctly;
3. All mechanical faults in hoistway have been eliminated; cabin and counterweight locate at center of the hoistway.

Set AutoTuneModeSel FC-13 (FX-20) to “1” on digital operator (0; rotation tuning, 1; static tuning), perform motor initial angle tuning according to the following procedures shown in Figure 7.3.

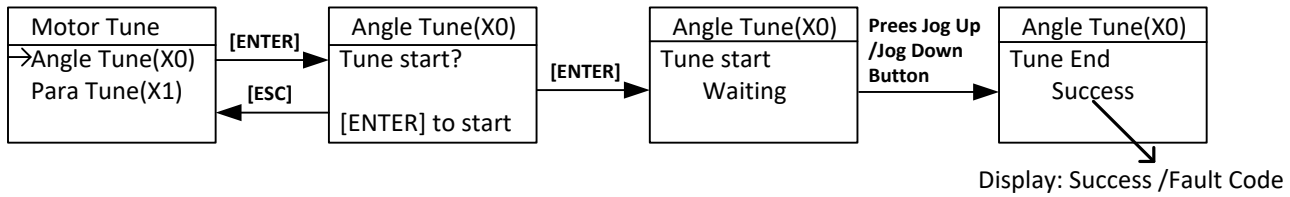

**FIGURE 7.3 MOTOR INITIAL ANGLE STATIC TUNING**

After pressing “Enter”, tuning starts. When digital operator indicates “Waiting”, press jog up or down button, Running contactor closes, motor will vibrate a little and give a noise, the duration depends on motor rated power and rated current, but no longer than 5s, this is static tuning period. (Make sure jog up or down button is pressed constantly, DO NOT release the button during this period.) Motor will then start and run in inspection speed, jog up or down, until digital operator indicates success, this is test running period. Finally, release the jog up or down button and finish the tuning procedure.

Please note the following items at motor static tuning;

1. To ensure safety, during tuning process, people is strictly forbidden to stay in car or hoistway;
2. Press up or down jogging button can base on the current cabin position;
3. The whole tuning procedures can be divided into two steps; static tuning and motor trial running, make sure there is no interruption between two steps. If no fault happens, before digital operator indicates success, press the jog up or down button constantly;
4. To achieve optimal control effect, it is recommended to repeat above tuning procedures 5 times, if the deflection of the results is small, take the average value.

If fault occurs in tuning, please refer to chapter 8 troubleshooting chart, locate the fault and solve it accordingly, then repeat tuning procedures.

## 7.6. Inspection Running

### 7.6.1 Inspection Running in Machine Room

1. Things to check before inspection running in machine room.
  - 1) Inspection switch in control cabinet is at “Inspection” position, inspection switch on car top and cabin should be in “Normal” position.
  - 2) Safety circuit and door interlock circuit work normal, DO NOT short door interlock circuit.
  - 3) After power on, emergency stop contactor, door interlock contactor, and power contactor in control cabinet are closed, check if the controller works normal and parameter setting is correct, in LCD indicator, elevator state is “INSP”.
  - 4) Connect the brake wiring to control cabinet properly.
2. Inspection running in machine room



**IMPORTANT**

**When the inspection running requirements in machine room are satisfied, press the Jog Up/Down button on the control cabinet, elevator will run up/down in set inspection speed.**

**Note; For integrated controller with ARD function, the inspection switch is called "Emergency Run Mode Switch"**

## 7.6.2 Inspection Running on Car Top/Cabin

If inspection running in machine room works normal, then inspection running on car top and cabin can be performed. If the up or down direction of the buttons of inspection running on car top and cabin are opposite with the actual running direction, please inspect its buttons' wiring, do not change the wiring in control cabinet.

## 7.7. Hoistway Learning

Hoistway parameter self-learning means elevator runs at a self-learning speed and measures every floor height and record the position of every switch in the hoistway. As the floor position is the foundation for elevator normal running, braking and floor display. Therefore, before normal running, hoistway parameter self-learning must be performed. Before hoistway parameter self-learning, inspection running in full trip must be performed too; elevator must be able to run normally from bottom limit to top limit.

Hoistway parameter self-learning procedure is as follows;

1. Make sure elevator meets the conditions for safety running;
2. Make sure all the switches in hoistway are installed and connected correctly, traveling cable and hoistway cable are connected correctly, and finish setting the HOP/display address;
3. Elevator in inspection mode, jog elevator down to the bottom limit (bottom limit is valid);
4. Enter elevator hoistway self-learning menu through digital operator, follow the learning procedures shown below in Figure 7.4

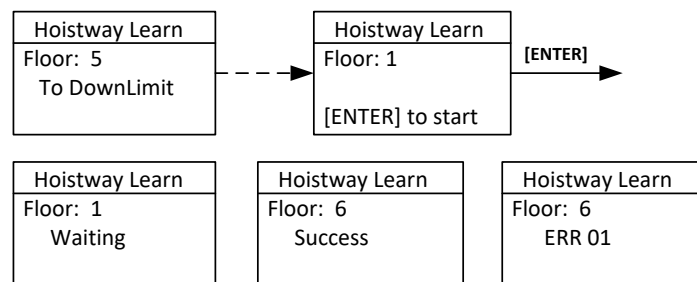

FIGURE 7.4 HOISTWAY PARAMETER SELF-LEARNING PROCEDURES

5. The results of learning can be seen from hoistway position parameter U00-U69 under monitor menu with unit of meter, please check the switches position after hoistway learning.
6. In self-learning process, if control system detects any abnormal phenomenon, self-learning will be terminated and give fault code, please refer to troubleshooting chart in chapter 8, find out the reason and solve it accordingly, then start hoistway parameter self-learning again.



**When self-learning process stops, only when LCD indicator shows “success” on digital operator, self-learning is completed successfully.**

## 7.8. Normal Speed Running

After hoistway parameter self-learning is completed successfully, normal speed running can be carried out. Procedure as follows;

1. Switch elevator to attendant mode (Manual)
2. In floor selection parameter D0 through digital operator, target floor can be set (details refer to chapter 4.4 **Commissioning Parameters Setup**). Then it is possible to perform single floor traveling, double floor traveling, multi-floor traveling and full trip traveling test. Through D1 parameter interface, input door open and close instruction to control the door.
3. Make sure elevator can start, accelerate, decelerate and leveling normally in normal speed running.
4. If running is abnormal, please check for parameters setting.

## 7.9. Elevator Comfort Level Adjustment

If comfort level and leveling accuracy of elevator running are not perfect, please follow procedures blow. First, check the mechanical system condition (Such as clearance of guide shoes, lubricating, steel rope, position of the rope hitch plate and else.) which might influence the comfort of elevator running. After checking all the mechanical parts, then do adjustment in controller.

As the controller control the motor running according to the given starting/braking speed curve, therefore shape of the given speed curve, motor feedback speed to controller and the timing logic of controller signals directly influence the comfort level of elevator running.

### 7.9.1 Adjustment for Start/Brake speed curve

Elevator running speed curve is shown below in Figure 7.5.

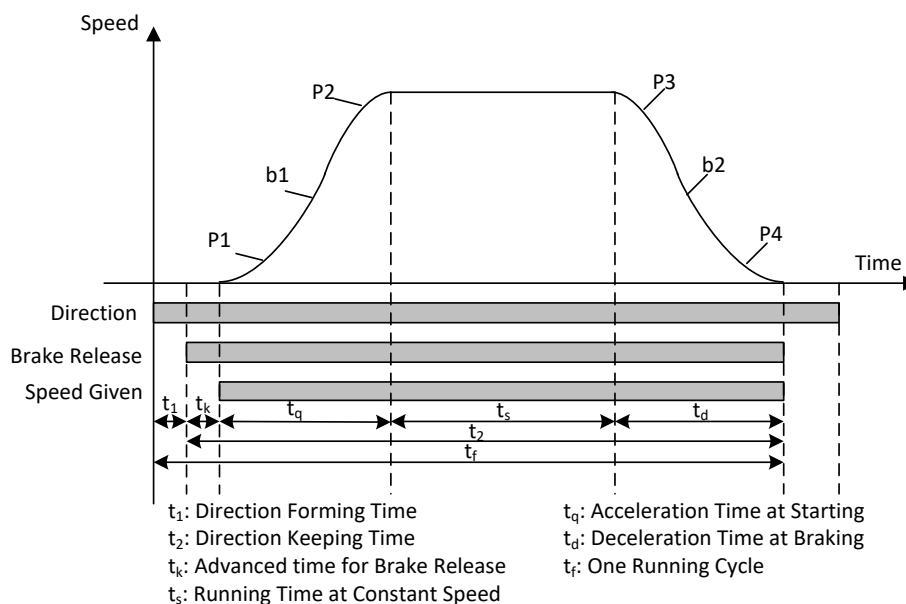

FIGURE 7.5 ELEVATOR RUNNING SPEED CURVE

### 1. Three parameters adjustment for motor starting S curve;

**1) P1;** Acceleration increase in starting section, it means the rate of elevator acceleration change. Smaller value means the slower starting section, the smoother running period and the lower the efficiency. On the other hand, faster at acceleration starting section means higher efficiency for elevator running.

**2) b1;** Acceleration in starting section, it means the rate of elevator speed change. Smaller value means the slower starting section, the smoother running period and the lower efficiency. On the other hand, faster at acceleration section means higher efficiency for elevator running.

**3) P2;** Acceleration decrease at end of starting section, it means the rate of elevator acceleration change. Smaller value means slower at end of starting section, the smoother running period and the lower efficiency. On the other hand, faster at acceleration ending section means higher efficiency for elevator running.

### 2. Three parameters adjustment for motor braking S curve;

**1) P3;** Deceleration increase at start of braking section, it means the rate of deceleration change, smaller value means slower at start of braking section is, smoother running period and lower efficiency. On the other hand, faster at brake starting section means higher efficiency for elevator running.

**2) b2;** Deceleration in braking section, it means the rate of elevator speed change. Smaller value means the slower braking section, the smoother running period and the lower efficiency. On the other hand, faster at braking section means higher efficiency for elevator running.

**3) P4;** Deceleration decrease at end of braking section, it means the rate of deceleration change. Smaller value means slower at end of braking section, smoother running period and the lower efficiency. On the other hand, faster at brake ending section means higher efficiency for elevator running.



**Commissioning at jobsite need to first guarantee the elevator running efficiency, then adjust the above 6 parameters to achieve optimal elevator running curve.**

## 7.9.2 Follow & Adjust Running Curve

To achieve the maximum level of comfort, integrated controller must control the motor and make feedback speed strictly following the change of running curve.

As the controller establishes the mathematic motor module based on the motor parameters input by customers, and controller perform decoupling control by this module on motor starting/braking. Therefore, customer should input the motor parameters correctly. (When motor parameter is not precise or not confirmed, we suggest customer perform motor parameter tuning.)

Proportional gain on the speed circle **F6-04** and integral gain **F6-05 or F7-05~F7-12** for PI section parameters also influence the motor tracking ability to speed curve. Generally, increasing the proportion gain will improve the reaction of the system and promote the tracking speed. However, if proportion gain is set too big, it will cause system vibration with high frequency and large motor noise. Increasing integral gain can improve the system anti-interference/tracking ability and improve the leveling precision but set integral gain too big will make system vibration, speed over adjustment and wave vibration.

Generally, it is recommended to first adjust the proportion gain, increase it right before system vibration threshold. Then adjust the integral gain, enable system with quick reaction and no over adjustment.

If system performance is not perfect at start or stop period (low speed period), try to control in multi-section PI, detail can be seen in 6.19.2 in **Chapter 6**.

### 7.9.3 Control Timing Adjustment

The control timing of this system can be seen Section **6.3** in **Chapter 6**, customer can adjust timing parameters and zero speed setting.

1. Timing adjustment; Refer to **section 6.3** Timing diagram under different state in **Chapter 6**.
2. Zero speed setting; This parameter is the threshold of zero speed. Main control board determines braking time by this value. If this value is too big, elevator will stop with speed, if too small it will delay door open after elevator stop.

Generally, for asynchronous motor, it is 5 RPM, for synchronous motor, it is 1 RPM.

## 7.10. Leveling Precision Adjustment

Leveling precision adjustment should be performed after comfort level adjustment is satisfied.

### 7.10.1 Basic Conditions for Elevator Leveling

1. Make sure the leveling switches and leveling inductor plates are installed in the right position.
2. Length of leveling inductor plates on every floor must be the same.
3. Leveling inductor plates must be installed vertically.
4. The position of leveling inductor plates should be precise. When elevator is at the leveling position, the center of the plate and center of two inductors should match together (refer to **Appendix 2**), otherwise elevator leveling will have deflection, which means in up or down running, elevator stops higher or lower than leveling position.
5. If magnetic inductors are adopted, please make sure the inductor plates inserting to the inductor sufficiently, otherwise it will influence the reaction time of inductor, in that way elevator will overruns the leveling position.
6. To ensure precise leveling, system require elevator to crawl for a certain distance before stop.
7. In practice, first make adjustment for a middle floor, until leveling is precise. Then, adjust the other floors on the base of these parameters.

After adjusting curve selection, ratio and integral gain in the above context, please make sure every time elevator runs up or down, when stop at middle floor, its leveling positions are the same (each deflection of stop position  $\leq \pm 2 \sim 3\text{mm}$ ).

### 7.10.2 Leveling Parameter Adjustment

If elevator still cannot achieve desired leveling condition with adjustment based on instructions in section 7.9.1 in Chapter 7, further adjustments can be done by parameters. After elevator stops in normal running, if running speed curve has no problem (for example, no sudden stop or overrun beyond leveling zone), if elevator overruns the leveling

position (it stops higher in up-running, lower in down-running), please decrease leveling adjustment parameter F1-17 (default; 50). If elevator cannot reach the leveling position (It stops lower in up running, higher in down running), increase leveling adjustment parameter F1-17, generally the range of this parameter is 40~60, if the adjustment is too big, please adjust driving parameter PI, or the shape of speed curve (F1-10~F1-15).

### 7.11. Terminal Switch Position

Top and bottom terminal switch signal is used for elevator force deceleration and floor position calibration, it should be installed in the position where it is triggered when elevator is 2.5m ahead of top (bottom) leveling position (for **1.6m/s lift**). The position should be determined as follows;

1. Switch elevator to inspection mode.
2. Set the inspection speed to 0.3m/s, jog run up(down).
3. Stop elevator when top(bottom) switch is triggered.
4. Distance between car sill and landing door sill should be  $2.5\pm 0.1\text{m}$ .

For the positions of terminal switches under other speed elevator, please refer to the **Appendix I**.

## Chapter 8 Troubleshooting

This chapter explains in detail the fault display of integrated controller, the reasons behind and possible solution. The fault display on integrated controller may come from elevator system errors, Hoistway learning errors, driver errors, motor parameters setting and Encoder phasing errors.

### 8.1. Elevator System Faults

Chart 8.1 Elevator System Fault List

Error Code	Definition	Possible Solution	Reset Level
Er2	Door inter-lock faults; Door inter-lock circuit open at elevator running	<ol style="list-style-type: none"> <li>1. Check door interlock feedback signals X30,X31,X32 and close limit. After door interlock closed, these signals should be all ON;</li> <li>2. Check door interlock and check if retiring cam has scratched door wheel;</li> <li>3. Check if hall door closed securely and if door close limit keep valid;</li> <li>4. Check hall door of each floor is fully closed, especially bottom floor. It may not close well because of airflow;</li> <li>5. Check if there's Er37 at same time. If there's Er37, please deal with it as Er37.</li> </ol>	D
Er3	Driver faults	Check driver fault code, find the cause of fault, and resolve it.	B
Er4	Elevator running in opposite direction with command	<ol style="list-style-type: none"> <li>1. Exchange phase "V" and "W" on motor;</li> <li>2. Exchange phase "A" and "B", on encoder terminal block or change in parameter setup.</li> </ol>	B
Er5	<ol style="list-style-type: none"> <li>1.Brake open fault; System output brake open but cannot receive feedback signal from brake monitor switches:After Y7, Y8 output, X11 and X16(brake relay feedback) has no feedback within 0.5 sec, or X15 and X19(Brake arm feedback) have no feedback within 2 sec.;</li> <li>2. Brake close fault; System has not output brake open but it detects the feedback signal of brake travel switch; There's no Y7 output, but X11 or X16 or X15 or X19 is valid.</li> </ol>	<ol style="list-style-type: none"> <li>1. Elevator stop with brake closed, Y7 has no output. Under the status of brake closed, check input LED indicators of X11,X16,X15 and X19. If the indicator is OFF, please set related parameter in F3-00 to ON. If the indicator is ON, please set related parameter to OFF. For example, X11 and X16 LEDs are off, X15 and X19 LEDs are on, then set F3-00-11=ON, F3-00-16=ON, F3-00-15=OFF, F3-00-19=OFF;</li> <li>2. In inspection mode, keep pressing both Up and Down button for more than 5 seconds to reset the fault. If the fault is not cleared, that means there's other fault in system and make fault code locked. Please save parameter and power off;</li> <li>3. After totally power off(Segment display and status LEDs all turn off), power on system;</li> </ol>	A

Chart 8.1 Elevator System Fault List (Cont'd)

Error Code	Definition	Possible Solution	Reset Level
Er5	<p>1.Brake open fault; System output brake open but cannot receive feedback signal from brake monitor switches:After Y7, Y8 output, X11 and X16(brake relay feedback) has no feedback within 0.5 sec, or X15 and X19(Brake arm feedback) have no feedback within 2 sec.;</p> <p>2. Brake close fault; System has not output brake open but it detects the feedback signal of brake travel switch; There's no Y7 output, but X11 or X16 or X15 or X19 is valid.</p>	<p>4. After power on, ER05 should be reset. If there's still other fault, please solve it. If there's no other fault, please turn to inspection mode, run up or down, check if brake contactor turn on after Y7 output and if X11 and X16 LEDs have change (ex. Before it is off and now it turns on). Check if X15 and X19 LEDs has change after brake open(ex. Before it is lighted on and now it is off);</p> <p>5. If Y7 has output but brake contactor doesn't turn on, it means contactor control circuit has fault. If brake contactor turn on but X11 LED has no change, that means feedback signal of brake contactor is wrongly connected. If brake contactor turns on but brake is not open, please check brake power circuit. If brake is open but X15 or X19 LED has no change, please check brake travel switch wiring;</p> <p>6.Check and recover above fault, then operate as step 2 to reset Er05 fault.</p>	
Er6	During elevator running, leveling zone input signal X9, X10 is always on.	Check leveling zone signal circuit and induction switch.	D
Er7	Encoder pulse not enough at elevator running.	Check the wiring from encoder to controller.	B
Er9	<p>STO fault; Running output do not matching feedback signal;</p> <p>1. After Y4 output, X17 has no feedback in 0.4s.</p> <p>2. X17 is enabled when Y4 has no output.</p>	<p>1. When elevator stop, Y4 has no output, STO should have no action. If X17 is ON ,please check STO control circuit, wiring may be wrong;</p> <p>2. STO has no action, check X17 LED on main board. If X17 is OFF, please set F3-00-17 to ON;</p> <p>3. Inspection running. Y4 has output and STO act. If Y4 has output but X17 is OFF, please check STO control circuit and feedback circuit;</p> <p>4.If all wiring are correct, please check if STO board is broken;</p> <p>5. If all above errors are solved, Er09 should be automatically reset. But if there're 5 times of this fault continuously, it cannot automatically reset. Please save parameter and power off to reset it.</p>	D/B

Chart 8.1 Elevator System Fault List (Cont'd)

Error Code	Definition	Possible Solution	Reset Level
Er10	Safety circuit open, X29 input are invalid.	<ol style="list-style-type: none"> <li>1. Check X29 LED on main board is ON or not. If X29 LED is off, that means safety circuit is open, please check which switch in safety circuit is open or wiring is wrong;</li> <li>2. If X29 LED is ON, please ensure F3-00-29 is ON;</li> <li>3. Ensure F4-06-11 is ON.</li> </ol>	D
Er11	Leveling switch signal missing; Elevator is running pass the floor, but there is not input at X9 /X10.	Check the leveling switches and its wiring.	D
Er12	Elevator pass top limit switch	<ol style="list-style-type: none"> <li>1. If elevator has moved out of leveling zone of top floor(exceed up leveling sensor position of top floor), please run down and make elevator no more higher than leveling zone of top floor;</li> <li>2. If elevator hasn't exceed top floor, please check if X7(top slowdown) and up leveling signal X9 act or not;</li> <li>3. If elevator is not at top slowdown position, please check X7 LED. If X7 is ON, please set F3-00-07 to OFF. If X7 is OFF, please set F3-00-07 to ON. After top slowdown switch act, X7 LED should have change. If X7 has no change please check top slowdown switch wiring.</li> </ol>	D
Er13	Elevator pass bottom limit switch	<ol style="list-style-type: none"> <li>1. If elevator has moved out of leveling zone of bottom floor (exceed down leveling sensor position of bottom floor), please run up and make elevator no more lower than leveling zone of bottom floor;</li> <li>2. If elevator hasn't exceed bottom floor, please check if X8(bottom slowdown) and down leveling signal X10 act or not;</li> <li>3. If elevator is not at bottom slowdown position, please check X8 LED. If X8 is ON, please set F3-00-08 to OFF. If X8 is OFF, please set F3-00-08 to ON. After bottom slowdown switch act, X8 LED should have change. If X8 has no change please check bottom slowdown switch wiring.</li> </ol>	D

Chart 8.1 Elevator System Fault List (Cont'd)

Error Code	Definition	Possible Solution	Reset Level
Er14	Floor position counter fault; After this fault, elevator will return to bottom or top floor slowly to correct position.	<ol style="list-style-type: none"> <li>1. Check if F5 group motor parameters, F8 group encoder parameters and F1-00 rated speed, F1-01 motor RPM are setting correctly. If it doesn't match, please correct it;</li> <li>2. Check encoder and related circuit if there's unstable connection. Make sure encoder shield cable connect to earth, and motor shield also need to connect to earth to reduce interfere;</li> <li>3. Check if there's rope slide and repair it;</li> <li>4. Check if there's vibration on leveling sensor(X9 and X10) during running;</li> <li>5. Check if there's vibration on up/down terminal(X7 and X8);</li> <li>6. After this fault, elevator will stop at nearest floor and then return to bottom or top floor slowing, then automatically recover.</li> </ol>	D
Er17	No drive output after running command.	Check parameters in controller or contact supplier.	B
Er18	Floor counter fault; After this fault, elevator will return to bottom or top floor slowly to correct position.	<ol style="list-style-type: none"> <li>1. It will show Er18 if elevator haven't done hoistway learning. Please turn to inspection mode and run to bottom limit, then complete hoistway learning;</li> <li>2. Check encoder and related circuit, check earth connection;</li> <li>3. Hoistway learning may be not precise, please learn it again.</li> </ol>	C
Er19	The deceleration distance for target floor is not enough. Elevator did not perform hoistway parameter learning after changing terminal switch location.	<ol style="list-style-type: none"> <li>1. Decrease "Least Speed" in user menu;</li> <li>2. Do hoistway parameter learning again.</li> </ol>	D
Er20	When elevator reaches top/bottom floor and get deceleration instruction, but elevator doesn't slow down; elevator did not perform hoistway parameter learning after changing terminal switch location.	<ol style="list-style-type: none"> <li>1. Increase controller PI gain parameters; Check the braking resistor specification;</li> <li>2. Make elevator running curve smoother;</li> <li>3. Do hoistway parameter learning again.</li> </ol>	D
Er21	Single running overtime	<ol style="list-style-type: none"> <li>1. Check motor parameters are setting correct or not;</li> <li>2. Check F1 group parameter, F1-03 inspection speed, F1-05 rescue speed and F1-06 Least speed are set too low, then correct it;</li> <li>3. Check if there's rope slide or car stuck status;</li> <li>4. Check if F2-12 over Time is set too small, we suggest 45s;</li> <li>5. Check leveling sensor is normal or not, if it has lost condition, please correct it;</li> <li>6. After software version 7125, this fault must be reset by pressing both UP and Down for 5 sec in inspection mode.</li> </ol>	A/B
Er22	Elevator has inspection signal input (X10 invalid) at elevator normal running.	Check inspection switch and related circuits.	D

Chart 8.1 Elevator System Fault List (Cont'd)

Error Code	Definition	Possible Solution	Reset Level
Er23	One of two leveling switch (X9, X10) is invalid at elevator normal running.	Check leveling switches and wirings.	D
Er25	Heat sensor protection; Braking resistor or motor is over heat (X13 invalid ).	<ol style="list-style-type: none"> <li>1. Check heat sensor act or not and check its wiring;</li> <li>2. If heat sensor has no action, please check X13 LED status. If LED is OFF, please set F3-00-23 to OFF. If X13 LED is ON, please set F3-00-23 to ON;</li> <li>3. Set F3-02=13 to turn off this function.</li> </ol>	D/B
Er26	Door inter-Lock error	<ol style="list-style-type: none"> <li>1. Check if X31 and X30 status are same when door close and open. If different, please check related wiring;</li> <li>2. If it is through door, please check if X32 and X30 are same. If different, please correct its wiring;</li> <li>3. Check door close limit signal C06 and C04(Rear door) in U3-00. When car door close, C06 should be ON(or C04 should be ON when rear door close). When car door open, C06 should be OFF(or C04 should be OFF when rear door open). If there's no change, please check door close limit switch or its wiring;</li> <li>4. If door close limit status is opposite from door interlock status, for example, car door is closed and C06 is OFF, or car door is open and C06 is ON. That means input type is reversed, please set F3-01-06 to ON. Same with C04.</li> </ol>	D
Er27	Spared		D
Er28	Top/bottom terminal (1st or 2nd) switch fault. (X7 or X8 valid when elevator outside their floor)	Check for terminal switches location and their wirings.	D/C
Er29	Communication interference too much (In system or in duplex communication).	<ol style="list-style-type: none"> <li>1. Check system ground condition;</li> <li>2. Check COP/LOP for possible damage that may influence CAN BUS communication.</li> </ol>	D
Er30	Door open fault (car cannot open door)	<ol style="list-style-type: none"> <li>1. Run elevator in inspection mode, give door open command and check Y20 for output signal;</li> <li>2. If Y20 has no output, need to check door open limit switch installation and input type. When door is closed, check C07 in U3-00, it should be OFF. When door is fully open, C07 should be ON. If C07 has no change, please check door open limit wiring. If C07 status is reversed, please set F3-01-07 to ON.</li> </ol>	D/C

Chart 8.1 Elevator System Fault List (Cont'd)

Error Code	Definition	Possible Solution	Reset Level
Er30	Door open fault (car cannot open door)	<p>3. If Y20 has output but car door cannot open (No action), please check door driver wiring if door motor can act or not;</p> <p>4. If Y20 has output but car door just open a little, then Y20 output cancel. Please check door open limit signal and ensure door open limit signal works normally. Then adjust F2-08 to extend door open output time;</p> <p>5. Check door interlock. After car door open, door contactor should release or X30 LED should be OFF. If door circuit is not open, that means door circuit is shorted.</p>	D/C
Er31	Door close fault (car cannot close door)	Normally due to door not installed properly and short circuit door interlock circuit. Check if door close and door interlock circuit are output at same time.	D
Er32	Floor number counting error.	A sudden power break may affect terminal/limit switches and cause floor number error. Elevator will then return to bottom floor for recalibration.	B
Er33	Motor star-sealed contactor fault; start-sealed output is different from feedback; 1. Y24 output but X22 has no feedback within 0.4 sec. 2. Y24 has no output but X22 is valid.	<p>1. Check X22 status in U1-00 while elevator stop, the signal should be OFF. If X22 is light on, please check if there's short circuit between motor and earth, and check if the connection between power board and mainboard is normal;</p> <p>2. If wiring is ok, no break circuit or short circuit but still error, please contact with factory;</p> <p>3. If this fault happens for 5 times, it will not be automatically reset. It need to power off to reset the fault.</p>	D/B
Er34	External 24V of power switch drop fault	Please check if 24V supplied by external switch power is connected normally. Sensor the voltage between D3-14 and D3-7 of mainboard. If system find the external voltage is lower than 16V, system will show fault. If voltage is too low, please check the reason of lack of voltage. If the 24V voltage is normal, please contact with factory.	D
Er35	System clock error	The circuit hardware on main board works abnormally, please contact with our factory.	B
Er36	Internal power +5V error	When system find the power of 5V is lower than 4.7V, this error occurs.	D
Er37	STO vibrate while brake opening	<p>1. Check if STO vibrate during elevator running;</p> <p>2. Check if X17 signal flicker during elevator running.</p>	D
Er38	Star-sealed vibrate while brake opening	<p>1. Check if star-sealed vibrate during elevator running;</p> <p>2. Check if X22 signal flicker during elevator running.</p>	D
Er39	Brake force detection fail, lack of brake force.	<p>1. For gearless motor, the brake force is not enough, please adjust or replace brake;</p> <p>2. This fault will not be reset by power off. Please keep pressing UP and DOWN button in inspection mode for 5 sec, then it can be reset;</p> <p>3. Set F4-07-27 to OFF to disable brake force detection.</p>	A
Er40	Brake invalid and car slide error	Safety protection function act. When system find the brake invalid, it controls the car creep around door zone to release passengers and then return to top floor and brake off again, but brake still fail to close. System announces brake invalid error and lock, will not recover until reset.	B

Chart 8.1 Elevator System Fault List (Cont'd)

Error Code	Definition	Possible Solution	Reset Level
Er41	Unintended slide error, pay attention to brake force.	Safety protection function act. When system find the brake invalid, it controls the car creep around door zone to release passengers and try to brake off. During the creeping, the brake successful turn off. System record this slide error as a warning of brake force but not display error. You can see it in Fault Record.	B
Er42	While ARD mode, system find brake force invalid.	The car slides, system announces error and record it to prevent power of UPS drop too low during creeping. Unless it may cause unpredictable danger.	B
Er43	Safety protection function act, the car runs out of door zone while re-leveling and caused door circuit been cut off. System announce door zone missing and lock the error until reset.	Remind maintenance man to solve the problem of door zone missing. To prevent door zone missing happens as well as brake force invalid, or creeping will cause the car run out of safety range.	B
Er44	While safety protection function works, signal of up limit has vibrated.	Safety protection act, then car creep around door zone. While up creeping, the signal from up limit(X5) vibrated. System will record this error and lock the error until reset.	B
Er45	While safety protection function works, signal of down limit has vibrated.	Safety protection act, then car creep around door zone. While down creeping, the signal from down limit(X6) vibrated. System will record this error and lock the error until reset.	B
Er46	While safety protection function works, signal of up terminal has vibrated.	Safety protection act, then car creep around door zone. While up creeping, the signal from up terminal(X7) vibrated. System will record this error and lock the error until reset.	B
Er47	While safety protection function works, signal of down terminal has vibrated.	Safety protection act, then car creep around door zone. While down creeping, the signal from down terminal(X8) vibrated. System will record this error and lock the error until reset.	B
Er48	Parameters of safety protection function has been wrongly set.	Enable safety protection but disable open in advance & re-level function.	D
Er49	Miss safety door zone signals.	Enable safety protection but cannot find door zone signals at leveling position.	B
Er50	Elevator parameter setting unreasonable	<ol style="list-style-type: none"> <li>1. Check if any floor in F4-00 is set to OFF, unstopable floor, confirm if this floor is really unstopable or not. If not, please set it to ON;</li> <li>2. Check if F0-01 home floor is set to unstopable floor in F4-00, please set it to stoppable floor;</li> <li>3. Check if F0-02 fire floor is set to unstopable floor in F4-00, please set it to stoppable floor;</li> <li>4. Check if F0-03 parking floor is set to unstopable floor in F4-00, please set it to stoppable floor;</li> <li>5. Check F4-04 and F4-05 if both front and rear door are set to OFF for one floor. Please set the side with available door to ON;</li> <li>6. Check if F1-25 duplex and F1-26 group are both set to 1. If it is not used, please set to 0.</li> </ol>	D
Er51	Drive module overheat protection.	When running, drive module met overheat protection. Elevator stopped at nearest floor.	D
Er52	The up and down door zone signals are opposite.	Exchange up and down door zone signal wires.	C

Chart 8.1 Elevator System Fault List (Cont'd)

Error Code	Definition	Possible Solution	Reset Level
ER53	For fire elevator, The CAN communication between elevator integrated controller and absolute value coding communication board is failure.	Please check the CAN communication connection, or whether the absolute value coding communication board is installed, for the special fire elevator program, the absolute value check function cannot be turned off.	D
ER54	light curtain obstructs error and car slows down to stop.	Light curtain is active during car running, check whether the light curtain signal is normal.	B
ER55	For fire elevator, the encoding of elevator integrated controller absolute value coding communication board is abnormal (the encoding floor counting is more than the total floor).	Absolute floor coding confusion, probably because the bistable switch is not operated by the magnetic bean or magnetic beans degaussing, please check the floor code from the top of the car with inspection mode.	B
Er56	Door close limit abnormal error	<ol style="list-style-type: none"> <li>1. When F4-06-16 = ON, or system is in door lock bypass operation, the door close limit is constantly inactive;</li> <li>2. When system is in automatic mode and elevator is in leveling position, or when system is in inspection mode. The door lock is open, but door close limit is constantly active;</li> <li>3. Please check whether the door close limit signal and car signals are correct.</li> </ol>	D
Er57	CAN communication abnormal error	Car top communication lose for modular system. Or when F4-06-22=ON, pit inspection board communication loses. Check whether car top board and pit inspection board are working properly.	C/D
Er58	Brake feedback switch X15 signal is abnormal.	Check the feedback wiring of the X15 brake micro switch or F3-00-15 input type.	A
Er59	Brake feedback switch X19 signal is abnormal.	Check the feedback wiring of the X19 brake microswitch or F3-00-19 input type.	A
Er60	Spared		A
Er62	X31 is valid while not using X31 as car door detection, or X14 is valid while no door interlock contactor.	Hall door and car door detection abnormal, please check if X31 is valid when F4-06-12=OFF, check if X14 is valid when F4-06-13=ON.	D
Er64	ARD car slip zero speed overtime	<p>Brutal drive elevator, when in ARD car slip self-rescue operation, system open the brake, but car is not moving in 2 seconds. Please check if the cabin or the brake is jammed.</p> <p>No brutal drive elevator, please check whether special function F4-07-00 is accidently enabled.</p>	C
Er65	ARD car slip over speed	Brutal drive elevator, when in ARD car slip self-rescue operation, the car slipping speed is over 0.3m/s, please check whether the star-sealed contactor is working properly, or the encoder feedback is correct.	C

Chart 8.1 Elevator System Fault List (Cont'd)

Error Code	Definition	Possible Solution	Reset Level
Er66	ARD car slip overtime	Brutal drive elevator, when in ARD car slip self-rescue operation, a single operation takes more than 150s and yet to find a leveling position. Please check the leveling signals are correct.	C
Er86	The top terminal input is valid, but secondary top terminal input is invalid (the end terminal switch is on the top car, so the secondary terminal must be reliable).	When the elevator speed is greater than or equal to 2m/s, or if the secondary terminal is enabled by F4-06-24, the integrated controller detects the timing sequence of the terminal and the secondary terminal.	B
Er87	The bottom terminal input is valid, but secondary bottom terminal input is invalid (the end terminal switch is on the top car, so the secondary terminal must be reliable).	When the elevator speed is greater than or equal to 2m/s, or if the secondary terminal is enabled by F4-06-24, the integrated controller detects the timing sequence of the terminal and the secondary terminal.	B
Er88	Terminal missing located in the top door area, but the top terminal input is invalid.	For the system that omit the top and bottom limit, the terminal signal is used to determine whether the elevator is running over limit with the door area signal combination. Therefore, if the elevator stops at the top floor, if the top terminal fault is not detected, please check the top terminal switch.	C
Er89	Terminal missing located in the bottom door area, but the bottom terminal input is invalid.	For the system that omit the top and bottom limit, the terminal signal is used to determine whether the elevator is running over limit with the door area signal combination. Therefore, if the elevator stops at the bottom floor, if the bottom terminal fault is not detected, please check the bottom terminal switch.	C
Er90	When the bypass is running, door-open completely signal and door-close completely signal is effective at the same time.	When the bypass is used in the inspection mode, the system detects door-close completely switch. If the door-open completely signal and door-close completely signal are effective at the same time, which indicates that the user has no connection or reversed the input type, so the system reported failure to prompt the user to connect wire, Otherwise, we cannot confirm whether the car door is properly closed.	C
Er91	The bypass operation signal of the door lock loop is detected fault.	Automatic operation is resumed, but bypass switch is not disconnected. Bypass check point X6 is effective. Check whether the bypass board plug-in is not restored or detect X6 input type.	C/D
Er92	The door locks short fault, there is a sealing line in the hall door or the car door circuit.	Please check the loop to remove the short connection.	C

Chart 8.1 Elevator System Fault List (Cont'd)

Error Code	Definition	Possible Solution	Reset Level
Er93	The operation of the safety circuit board is abnormal, and the function of the door lock short connection cannot be used normally.	<ol style="list-style-type: none"> <li>1. Check if SJT-ZPC safety relay board has connection fault;</li> <li>2. Set parameter F3-00-22=ON, F3-00-23=ON correctly;</li> <li>3. Elevator at leveling position, the safety zone signal of safety relay board should be valid. Safety relay board act, X23 input indicator on mainboard should turn on. If the sensors for safety zone or relay doesn't act, please check relative circuit. If safety relay has acted but X23 doesn't turn on, please check the connection between safety relay board and mainboard;</li> <li>4. Elevator at leveling position, X23 is valid. After Y0 on mainboard has output, safety relay board will act. X22 input indicator will light on. If safety relay board doesn't act (X22 doesn't turn on) after Y0 output or Y0 has no output but safety relay board acts (X22 turn on), it means the wiring of safety relay board is wrong;</li> <li>5. Elevator isn't at leveling position, X23 should be invalid. If X23 is valid, please check safety zone signal and X23 wiring.</li> </ol>	C
Er94	Pb parameters of S curve is unreasonable, deceleration distance is too long, it may not be able to stop while single floor running and stop at next stop.	<ol style="list-style-type: none"> <li>1. Change bp parameter of curve;</li> <li>2. Increase F1-10 and F1-11 but do not exceed 0.7;</li> <li>3. Increase F1-12~F1-15 but do not exceed 0.7.</li> </ol>	D
Er95	During the single start operation, when the contactor is pulled in, the rear door Interlock loop jitter exceeds 20 times, and the door lock loop is abnormal.	Please check the door lock loop, there may be a virtual connection.	B
Er96	The protocol binding of COP and LOP don't match the controller's, cannot operate car call and hall call.	<ol style="list-style-type: none"> <li>1. Release binding by setting FX-42=0, it will also reset fault. If you need binding function, please start binding again;</li> <li>2. Re-binding. Firstly set FX-42=0 then set FX-42=No. (new binding code) and save parameter.</li> </ol>	D
Er97	Minimum curve deceleration speed is less than the length of floor plate, it may cause single floor running unstoppable.	<ol style="list-style-type: none"> <li>1. Increase F1-06 Least speed;</li> <li>2. Slightly increase F1-10~F1-11.</li> </ol>	D
Er98	Drive program locked	Please contact with supplier.	D
Er99	Logic program locked.	Please contact with supplier.	D

**Note:**

**1. Elevator fault reset conditions**

Reset level	Fault reset conditions
A	In inspection mode, press both Up and Down for 5 sec to reset. (need professional to manually reset at site)
B、C、D	Power off control system and power on again
C、D	Turn to inspection mode
D	Automatically reset

2. Adding sub code in fault records: C0, C0=0 fault has no sub code, C0≠ fault has sub code (fault in chart 8.1 with \*).

3. In default setting, it shows fault code when fault occurs, but not show sub code. During fault looping display, press UP button, it will show corresponding sub code, press ESC to exit sub code show. For example, fault Er02, sub code is

5. When there's fault, it shows E-02, after pressing UP button, it shows E02.5, press ESC to exit.

**4. Sub code of fault explanation.**

Fault	Sub code	Analysis
Er2	1	Car door open (X31)
	2	Hall door open (X30+X32)
	3	Rear car door open (X30)
	4	Door contactor turn off
	5	Running contactor turn off
	6	During door bypass running, door close limit is invalid
	7	Safety circuit open
	8	Door interlock or running contactor vibrate
Fault	Sub code	Analysis
Er5	1	Brake contactor has no action during brake open or feedback signal X11 or X16 lost.
	2	When brake off, brake contactor adhered or feedback X11 and X16 keep valid.
	3	When brake off, X15 travel switch feedback signal is valid.
	4	When brake off, X19 travel switch feedback signal is valid.
	5	When brake off, both X15 and X19 travel switch feedback signal are valid
	6	When brake on, X15 travel switch feedback is always invalid.
	7	When brake on, X19 travel switch feedback is always invalid.
	8	When brake on, X15 and X19 travel switch feedbacks are always invalid.
	9	While brake open, brake contactor KLZ1 feedback X13 invalid.
	10/A	While brake off, brake contactor KLZ1 feedback X13 is abnormally valid.
	11/B	Using STO and electric star-seaked, the feedback X11 doesn't match brake device output Y8.
Er9	1	Y9 running enable has no output but X16 feedback is abnormally valid
	2	Y9 running enable has output but X16 feedback is abnormally invalid
Er10	1	Safety circuit open
	2	Safety contactor off

Er11	1	Elevator has run over floor distance but leveling signal X9 and X10 keep invalid.
	2	There's two leveling in car top communication but leveling signal X9 and X10 keep invalid.
Er12	1	X5 Top limit valid
	2	Soft limit type, up terminal X7 is valid and run out of up leveling sensor.
Er13	1	X6 Bottom limit valid
	2	Soft limit type, down terminal X8 is valid and run out of down leveling sensor
Er14	1	Elevator run up, the leveling single of current floor is valid in advance.
	2	Elevator run up, the leveling single of current floor is valid late.
	3	Elevator run down, the leveling single of current floor is valid late.
	4	Elevator run down, Elevator run down, the leveling single of current floor is valid in advance.
Er17	1	Controller runs but no running feedback from inverter.
	2	Controller doesn't run but inverter has running feedback.
Er23	1	After running bypass a floor, X9 keeps invalid.
	2	After running bypass a floor, X10 keeps invalid
Er25	1	X21 Overheat
	2	X14 brake overheat input valid
	3	C29 front door motor overheat
	4	C29 rear door motor overheat
	5	Brake short circuit
	6	Brake over current
	7	Brake power board enable fault
	8	Brake power board hardware fault
Er26	1	X31 and X30 are not matched
	2	X32 and X30 are not matched
	3	F4-06-16=ON, but it find no close limit after door closed
	4	F4-06-16=ON, Door circuit closed but find no closelimit.
	5	Through door elevator but haven't set F4-06-04=ON
Er28	1	Down terminal becomes valid but not at bottom floor
	2	Up terminal becomes valid but not at top floor
Er30	Null	Door motor fault. After receiving open command, motor has no action
		Car top board fault, open command is not output
		The wiring from car top board to door motor has fault
Er31	1	Door close limit is valid but door circuit is not closed
	2	Door close ends, but X31 hall door has no feedback signal
	3	Door close ends, but X32 hall door has no feedback signal.
	4	Door close ends, but X14 hall door has no feedback signal.

	5	Door close ends, but X30 door lock has no feedback signal.
	6	Door close ends, but no close limit feedback signal
<b>Fault</b>	<b>Sub code</b>	<b>Analysis</b>
Er33	1	X11 star-seaed feedback valid, abnormal open
	2	X11 star-seaed feedback invalid, cannot open
	3	Electric star-seaed feedback valid, abnormal open
	4	Electric star-seaed feedback invalid, cannot open
	5	Shaft position information abnormal, cannot complete star-sealed testing.
	6	Star-sealed testing fail, star-sealed function failure
	7	X11 star-sealded contactor feedback valid, anormalopen
Er39	1	Find motor has moved
	2	Find motor has feedback speed
	3	Find movement of motor wheel
	4	While leveling, rope slip has been detected for many times.
	5	During brake force testing, testing exit because of system fault or door open
Er50	1	Duplex and group control cannot be set at same time
	2	Group and through door cannot be set at same time
	3	Homing floor cann't be set as unavailable
	4	Fire floor cann't be set as unavailable
	5	Parking floor cann't be set as unavailable
	6	Front & rear door cannot be set both unavailable
	7	Drive program don't support single brake force testing
	8	Brake monitoring function cannot be canceled
Er60	1	UCMP Protection Fault
	2	Use X24 as asyn motor UCMP protection detection, X24 has acted.
Er92	1	During door bypass testing, X22 has no feedback,SJT-ZPC-V2A board action abnormal
	2	During door bypass testing, door bypass signal abnormal, X30 is not connected.
	3	During door bypass testing, after front door open, front car door signal X31 still valid.
	4	During door bypass testing, after front door open, front door close limit still valid.
	5	During door bypass testing, after rear door open, rear door close limit still valid.
	6	During door bypass testing,after rear door open, rear landing door signal X32 abnormal valid.
	7	Through door,but F4-06-04 is set to OFF
	8	Open limit abnormal, before hall door and car dooorfully open, open limit becomes valid.
Er93	1	After elevator leaves leveling position, safety zone signal X23 still valid.
	2	Y0 has no output but safety relay board feedback X22 is valid.
	3	Y0 has output but safety relay board feedback X22 keeps invalid.
	4	Elevator is at leveling position but safety zone X23 is invalid.

## 8.2. Hoistway Parameter Self-Learning Faults

Chart 8.2 Hoistway Parameter Self-Learning Fault List

Error Code	Definition	Possible Solution
LER=0	System running error	Press "ESC" to exit learning, check fault record shown in Chart 8.1
LER=1	Pulse input phase reverse	Exchange phase A and phase B in encoder.
LER=2	Bottom terminal 1 switch input repeat.	Bottom terminal 1 switch installation error, causing multiple terminal switch input or bottom terminal 1 switch signal shake. Check related switches.
LER=3	Bottom terminal 1 switch signal lost (elevator >2.0m/s)	Bottom terminal 2 switch enable before bottom terminal 1 switch or bottom terminal 1 switch signal lost. Check related switches.
LER=4	Bottom terminal 2 switch signal repeat. (elevator >2.0m/s)	Bottom terminal 2 switch installation error, causing multiple terminal switch input or bottom terminal 2 switch signal shake. Check related switches.
LER=5	Bottom terminal 2 switch signal lost (elevator >2.0m/s)	Top terminal 2 switch enable before bottom terminal 2 switch or bottom terminal 2 switch signal lost.
LER=6	Top terminal 2 switch signal repeat. (elevator >2.0m/s)	Top terminal 2 switch installation error, causing multiple terminal switch input or top terminal 2 switch signal shake. Check related switches.
LER=8	Top terminal 2 switch signal lost (elevator >2.0m/s)	Top terminal 1 switch enable before top terminal 2 switch or top terminal 2 switch signal lost.
LER=9	Bottom terminal 1 switch signal lost	Top terminal 1 switch enable before bottom terminal 1 switch or bottom terminal 1 switch signal lost.
LER=10	Top terminal 1 switch signal repeat	Top terminal 1 switch installation error, causing multiple terminal switch input or top terminal 1 switch signal shake. Check related switches.
LER=11	Top terminal 1 switch signal lost	Top limit switch enables before top terminal 1 switch or top terminal 1 switch signal lost.
LER=12	Total floor setting error	Check total floor number match actual floor number. Check leveling inductor plates on every floor.
LER=14	Two leveling inductors cannot trigger together	Leveling inductor plate on this floor cannot cover two inductors or missing one leveling inductor.
LER=15	Press "ESC" in the middle of hoistway parameter learning process.	Cancel the learning by pressing "ESC".
LER=17	Up/Down leveling switch enable at same time	Wiring of two switches is parallel connection by mistake, or bottom limit switch is installed close to 1st floor leveling position.
LER=18	Hoistway data saving error	▲ Please contact supplier at once.
LER=19	Both leveling switch signal enable together when arrive at top limit switch.	Move up top limit switch.
LER=20	Bottom limit switch too high	Lower the bottom limit switch.
LER=21	When elevator reaches top limit switch, bottom terminal 1/2 switch is valid.	Check the switches position and their wirings.
LER=22	When elevator start from bottom limit switch, top terminal 1/2 switch is valid.	Check the switches position and their wirings.
LER=23	No pulse feedback after starting.	Check the wire of PG card.
LER=24 (25)	The up and down door zone signals are opposite in hoistway learning.	Check installation position of up and down door zone sensor, exchange their wires.

Chart 8.2 Hoistway Parameter Self-Learning Fault List (Cont'd)

Error Code	Definition	Possible Solution
LER=26	Leveling sensor and safety zone signal are reverse	<ol style="list-style-type: none"> <li>1. Check if car top safety zone signal (MQ2) and leveling signal (MQ1) are reverse. After adjustment, power off and do hoistway learning again.</li> <li>2. If safety zone and leveling sensor signals are correct, it may be caused by communication noise. Disconnect MQ2 safety zone signal and then do hoistway learning. After complete, connect MQ2 again.</li> </ol>
LER=30	Elevator is not at bottom limit while hoistway learning.	Inspection running to bottom limit, then start hoistway learning.

**Note;** System has 2 top and 2 bottom terminal switches for elevator speed >2.0m/s.

### 8.3. Driver Faults

Chart 8.3 Driver Fault List

Error Code	Display	Definition	Possible Causes	Possible Solution
DF1	UV	<b>DC bus under voltage</b> (for 400V drive, 380V at UV protection; for 200V drive, 220V at UV protection)	<ol style="list-style-type: none"> <li>1. Phase lost on input supply;</li> <li>2. Instantaneous power lost;</li> <li>3. Excessive input voltage fluctuation;</li> <li>4. Loose terminals at input;</li> <li>5. Surge Resistance didn't release;</li> <li>6. UPS running, but X18 is in valid.</li> </ol>	<ol style="list-style-type: none"> <li>1. UV error after power ON; Check input power supply; Check input power cable terminals; Check cable between main board and power board;</li> <li>2. Without load, up running is normal, but down running shows UV error, Check surge resistance;</li> <li>3. UV error while ARD running, Check X18 connection;</li> <li>4. UV error after power off. This is normal condition, system record each time of power off by UV error.</li> </ol>
DF2	OV	<b>DC bus over voltage</b> (for 400V drive, 760V at OV protection; for 200V drive, 410V at UV protection)	<ol style="list-style-type: none"> <li>1. Too short deceleration time;</li> <li>2. Brake resistance value mismatch;</li> <li>3. Supply voltage too high;</li> <li>4. No connection to braking resistor or abnormal braking resistor or lack of capacity.</li> </ol>	<ol style="list-style-type: none"> <li>1. Increase deceleration time;</li> <li>2. Connect capacity and connection of brake resistor;</li> <li>3. Check power supply.</li> </ol>
DF3	OH	<b>Heat sink overheated</b> Find temperature of module is higher than a preset value and keep for certain time; Find temperature of module is lower than zero degree and keep for certain time;	<ol style="list-style-type: none"> <li>1. Excessively ambient temperature;</li> <li>2. Damaged cooling fan;</li> <li>3. Existence of heat source around;</li> <li>4. Ambient temperature is below zero degree;</li> <li>5. Bad connection between main board and power board.</li> </ol>	<ol style="list-style-type: none"> <li>1. Reduce ambient temperature;</li> <li>2. Remove heat source around;</li> <li>3. Check the fan and wiring;</li> <li>4. Set FX-21 to OFF (disable minus temperature warning);</li> <li>5. Check cable between main board and power board.</li> </ol>
DF4	IF	<b>IPM fault</b> Find drive module has serious short circuit error, system trigger a hardware over-current protection. Please get rid of external short circuit before retrying	<ol style="list-style-type: none"> <li>1. IPM over current/short circuit;</li> <li>2. IPM over heat;</li> <li>3. Abnormal IPM control power (UV);</li> <li>4. Motor wire adhered or short to ground;</li> <li>5. Abnormal star-sealed contactor action.</li> </ol>	<ol style="list-style-type: none"> <li>1. Check output short circuit;</li> <li>2. Check motor short circuit;</li> <li>3. Check star-sealed contactor action;</li> <li>4. Contact with supplier.</li> </ol>

Chart 8.3 Driver Fault List (Cont'd)

Error Code	Display	Definition	Possible Causes	Possible Solution
DF5	OC	<b>Overcurrent</b> Phase current of controller has exceeded limit and keep for certain time	<ol style="list-style-type: none"> <li>1. Inverter output short circuit;</li> <li>2. Machine over-load;</li> <li>3. Accel/decel time too short;</li> <li>4. Encoder signals have a bad connection;</li> <li>5. Wrong motor or encoder parameter setting;</li> </ol> (1)Wrong original point (Gearless); (2)Rated slip is too large (Geared); (3)Wrong poles setting; (4)Wrong encode pulse setting; (5)Wrong P & I parameter setting.	<ol style="list-style-type: none"> <li>1. Check motor short circuit;</li> <li>2. Check accel/decel time, slow down if needed;</li> <li>3. Check if inverter's capacity match load;</li> <li>4. Check encoder connection;</li> </ol> (1) Check original point (Gear less); (2) Check rated slip (Geared); (3) Check poles setting; (4) Check encoder pulse setting; (5) Check P & I parameter setting.
DF6	CF	<b>CPU faults</b> Controller abnormal	Electro-Magnetic interference.	Too much interference.
DF7	OS	<b>Elevator over speed</b> the speed feedback exceeds the speed limit and last longer than set time.	<ol style="list-style-type: none"> <li>1. Max speed /last time set incorrect;</li> <li>2. Speed over-tuning;</li> <li>3. Encoder feedback incorrect;</li> <li>4. Wrong motor parameters setting.</li> </ol>	<ol style="list-style-type: none"> <li>1. Check speed limit setting;</li> <li>2. Check the P/I parameter;</li> <li>3. Check encoder;</li> <li>4. Check motor parameters.</li> </ol>
DF8	OE	<b>Speed over deviation</b> the speed deviation exceeds the allowable range(F9-03) and last longer than set time.	<ol style="list-style-type: none"> <li>1. System overload;</li> <li>2. Accel/decel time short;</li> <li>3. Parameter setting wrong;</li> <li>4. Encoder cannot work properly;</li> <li>5. Brake wrongly act;</li> <li>6. Wrong allowable range set.</li> </ol>	<ol style="list-style-type: none"> <li>1. reduce system load;</li> <li>2. Increase accel/decel time;</li> <li>3. Check the parameters;</li> <li>4. Check the encoder;</li> <li>5. Exchange motor phase sequence or exchange A+/A- and B+/B- wire;</li> <li>6. Check brake action.</li> </ol>

Chart 8.3 Driver Fault List (Cont'd)

Error Code	Display	Definition	Possible Causes	Possible Solution
DF9	PGO	<p><b>PG disconnects</b> Did not receive encoder signal at operation. PG card type setting is different with actual one, system cannot identify it.</p>	<ol style="list-style-type: none"> <li>Encoder wiring break, loosen or wrong connection;</li> <li>Encoder damaged;</li> <li>Wrong PG type setting;</li> <li>PG card damaged;</li> <li>Brake not open.</li> </ol>	<ol style="list-style-type: none"> <li>check encoder wiring;</li> <li>Check encoder;</li> <li>Check if F8-02 PG type is same with actual PG card;</li> <li>Check connection between PG card and main board;</li> <li>Check if brake can open;</li> <li>If software version is old, please enter Fault report-&gt;Controller Fault, and find E2, E3 value; Incremental encoder; (1)E3=35, no speed feedback; (2)E2=16, U/V/W signals error; Sin/Cos encoder; (1)E3=35, no speed feedback; (2)E3=29,31,36, abnormal communication between main board and SPG card; (3)E3=28 or 34, C/D signal error; (4)E3=32 or 33, A/B/C/D signals are highly similar;</li> <li>If software version is new, these errors are DF18, DF19 and DF20.</li> </ol>
DF10	FF	<b>Flash memory fault</b>	Data fault at saving parameters.	Please contact supplier.
DF11	BF	<p><b>Base lock circuit error</b> When system find baselock valid and receive running command, but running condition isn't ready.</p>	<ol style="list-style-type: none"> <li>Wiring for baselock at X14 is incorrect;</li> <li>Setting electric level for baselock at X14 is incorrect.</li> </ol>	<ol style="list-style-type: none"> <li>Check the wiring at X14;</li> <li>Modify the parameters.</li> </ol>
DF12	OL	<p><b>Motor overload</b> current output exceed 150% (200%) rated value for 60s (10s). Motor current exceed 150% (200%) rated value for 60s (10s).</p>	<ol style="list-style-type: none"> <li>System load too heavy;</li> <li>System power rating too low;</li> <li>Low capacity controller.</li> </ol>	<ol style="list-style-type: none"> <li>Reduce system load;</li> <li>Change a more suitable controller;</li> <li>Change motor or increase F5-08 rated current properly to promote overload capacity.</li> </ol>

Chart 8.3 Driver Fault List (Cont'd)

Error Code	Display	Definition	Possible Causes	Possible Solution
DF13	MC	<b>MC contactor bad action</b> Controller main contactor M C does not close after given close command for set time.	<ol style="list-style-type: none"> <li>Wrong wiring for MC contactor;</li> <li>MC contactor damaged;</li> <li>Wrong FX-23 surge feedback type setting;</li> <li>Drive power on power board is abnormal.</li> </ol>	<ol style="list-style-type: none"> <li>Try to reset the power, if this error come again, contact supplier for replacement;</li> <li>Change FX-23 status, then power off and power on again.</li> </ol>
DF14	BR	<b>Brake unit fault</b> While system find DC bus voltage reach braking range, but braking tube keep open and last over preset time.	<ol style="list-style-type: none"> <li>defective brake cable or damaged brake elements or IGBT module;</li> <li>External brake resistor disconnected or not connected;</li> <li>Bad connection between the main board and the power board.</li> </ol>	<ol style="list-style-type: none"> <li>Check brake resistor;</li> <li>Replace the controller;</li> <li>Check the main board and the power board connector.</li> </ol>
DF15	OF	<b>Output phase lost</b> System find phase lost or break, running condition is not ready	<ol style="list-style-type: none"> <li>Output cable break or loose terminal;</li> <li>Motor stator cable disconnect.</li> </ol>	<ol style="list-style-type: none"> <li>Check output cable/terminal;</li> <li>Check motor stator cable;</li> <li>Set FD-21. BIT2 to 1 to disable this detection.</li> </ol>
DF16	SCF	<b>Output current remains at elevator stop</b> After the system executes the stop instruction, the output current is not zero and the preset time is kept.	<ol style="list-style-type: none"> <li>Controller damaged;</li> <li>Cabinet works abnormally.</li> </ol>	<ol style="list-style-type: none"> <li>Change the controller;</li> <li>Check cabinet wiring.</li> </ol>
DF17	SRF	<b>Elevator slips after stop</b> After the system executes the stop command, the encoder's feedback speed is not zero.	<ol style="list-style-type: none"> <li>Brake/encoder loose;</li> <li>Encoder interference.</li> </ol>	<ol style="list-style-type: none"> <li>Fasten brake/encoder;</li> <li>Remove interference source.</li> </ol>
DF18	UF	Incremental; <b>Signal U of encoder wire lost</b> Sin/Cos; <b>Signal C and D abnormal</b>	<ol style="list-style-type: none"> <li>Encoder damaged or wiring incorrect;</li> <li>Wrong PG type setting.</li> </ol>	<ol style="list-style-type: none"> <li>Check encoder and wirings;</li> <li>Correct PG type setting.</li> </ol>
DF19	VF	Incremental; <b>Signal V of encoder lost</b> Sin/Cos; <b>A, B, C, D signals are highly similar</b>	<ol style="list-style-type: none"> <li>Encoder damaged or wiring incorrect;</li> <li>Wrong PG type setting.</li> </ol>	<ol style="list-style-type: none"> <li>Check encoder and wirings;</li> <li>Correct PG type setting.</li> </ol>

Chart 8.3 Driver Fault List (Cont'd)

Error Code	Display	Definition	Possible Causes	Possible Solution
DF20	WF	Incremental; <b>Signal W of encoder wire lost</b> Sin/Cos; <b>Abnormal communication between SPG card and main board</b>	<ol style="list-style-type: none"> <li>1. Encoder damaged or wiring incorrect;</li> <li>2. Wrong PG type setting;</li> <li>3. Bad connection between the main board and the PG card.</li> </ol>	<ol style="list-style-type: none"> <li>1. Check encoder and wirings;</li> <li>2. Correct PG type setting;</li> <li>3. Check whether the PG card is fastened to the main board.</li> </ol>
DF21	DF	<b>Parameter setting error</b> System find rated current/no-load current/rated slip/ poles/pulse setting error.	Parameter setting error Check rated current/no-load current/ rated slip/ poles/pulse setting.	Check parameter setting.
DF22	SDF	<b>Internal programmer self-check error</b> The system detected the types of faults that cannot be classified into routine fault types.	Internal data setting error.	Please contact with supplier.
DF23	150	<b>Current collection sensor error</b> When the elevator starts, the system detected that the instantaneous current value of the current sensor is not near the zero point.	<ol style="list-style-type: none"> <li>1. Bad contact between main board and drive power;</li> <li>2. Hardware error.</li> </ol>	<ol style="list-style-type: none"> <li>1. Please with contact supplier;</li> <li>2. Check the main board and driver power board connection.</li> </ol>
DF24	151	<b>Overtime at zero speed</b> The system has detected that the elevator controller has been given a zero-speed state and exceeds the zero-speed timeout time.	Drive controller keep too long time under zero speed.	Check if inspection speed or rated speed is reasonable.
DF25	152	<b>Baselock error</b> System detect baselock signal and cannot reset error	<ol style="list-style-type: none"> <li>1. Bad contact among chips on mainboard;</li> <li>2. Bad contact among main board and power board.</li> </ol>	<ol style="list-style-type: none"> <li>1. Check the connection between; Bad contact among chips on mainboard;</li> <li>2. main board and power cable. Replace main board.</li> </ol>
DF26	153	<b>Sequence of load compensation is abnormal</b> When the load compensation device starts, the system detects the rotation of the motor.	While drive controller operate load compensation, the sequence is abnormal. Or brake open time is too short.	Check the brake and if Brake ON Time setting is too short.

Chart 8.3 Driver Fault List (Cont'd)

Error Code	Display	Definition	Possible Causes	Possible Solution
DF27	154	<b>Angle tuning fail</b> Angle tuning with load not completed.	Angle tuning fail with fault.	Solve angle tuning fault first, then do it again. <b>Attention; Don't run elevator without successful auto tuning, or it will lose control.</b>
DF28	155	<b>Internal communication error</b> The system has detected the abnormal communication in the main board.	<ol style="list-style-type: none"> <li>1. Internal communication between controllers is abnormal;</li> <li>2. Component on mainboard is abnormal;</li> <li>3. Elevator controller gives wrong commands.</li> </ol>	<ol style="list-style-type: none"> <li>1. Check if there is serious EMI or contact with supplier;</li> <li>2. Change the main board.</li> </ol>
DF29	156	<b>The running mode of machine is abnormal</b> speed source selection on F9-01 cannot match current logic.	Speed source selection F9-01 do not adapt to current control logic.	When normal running, confirm F9-01=2.
DF30	157	<b>Power of bottom case identification error</b> The main board cannot correctly identify the bottom case configuration information.	<ol style="list-style-type: none"> <li>1. Connection between main board and power drive board is bad;</li> <li>2. Component on mainboard is abnormal;</li> <li>3. Component on power drive board is abnormal.</li> </ol>	<ol style="list-style-type: none"> <li>1. Check the connection between main board and drive power;</li> <li>2. Change main board;</li> <li>3. Change power board.</li> </ol>
DF31	158	<b>Communication error between drive modules</b> Detection of communication error between drive modules	Communication of internal drive chip is abnormal.	<ol style="list-style-type: none"> <li>1. Check if there is serious EMI or contact with supplier;</li> <li>2. Change main board.</li> </ol>
DF32	159	<b>Encoder Z (or R) signal is abnormal</b> Motor has run for over 2 rounds but didn't find Z signal.	<ol style="list-style-type: none"> <li>1. The controller finds disconnection or interference in Z pulse;</li> <li>2. Component on mainboard is abnormal;</li> <li>3. Component on PG card is abnormal.</li> </ol>	Check if there is interference or broken wire of Z pulse.
DF33	160	<b>Before start, feedback speed is abnormal.</b> Before elevator start, system find the feedback speed is over limit.	<ol style="list-style-type: none"> <li>1. Encoder signal anomaly;</li> <li>2. Brake force may be not enough or already open.</li> </ol>	<ol style="list-style-type: none"> <li>1. Check A &amp; B signals of encoder;</li> <li>2. Check brake.</li> </ol>

Chart 8.3 Driver Fault List (Cont'd)

Error Code	Display	Definition	Possible Causes	Possible Solution
DF34	161	<b>While brake force detecting, feedback movement of encoder is too long.</b>	<ol style="list-style-type: none"> <li>1. Encoder feedback signal anomaly;</li> <li>2. Brake force may be not enough or already open.</li> </ol>	Check the brake and encoder.
DF35	162	<b>While safety protecting, motor has crept too long</b> When the system is in the state of security protection, it is detected that the encoder feedback displacement is too large.	<ol style="list-style-type: none"> <li>1. Encoder feedback signal anomaly;</li> <li>2. Brake force may be not enough or already open.</li> <li>3. The setting of control parameter is not reasonable.</li> </ol>	Check the brake, encoder and parameter setting related to safety protection
DF36	163	<b>Lack of phase protection for 3-phase input power</b> During the operation of the system, the input phase is detected lack, and the shell driving power is abnormal.	<ol style="list-style-type: none"> <li>1. While running, system find lack of phase.</li> <li>2. Check if there's IF error in Fault report. If yes, solve error according to IF error.</li> <li>3. Bad contact between main board and power board.</li> </ol>	<ol style="list-style-type: none"> <li>1. Check 3-phase input power;</li> <li>2. Check if there's short circuit of output 3-phase;</li> <li>3. Check cable between main board and power board;</li> <li>4. While using one phase, set FD-21. BIT0=1 to ignore lack of phase error.</li> </ol>
DF37	164	<b>Three-phase output line short circuit</b> Short circuit between 3-phase output or short to earth or to N line.	<ol style="list-style-type: none"> <li>1. There is short circuit among 3-phase output or output to earth or output to N line;</li> <li>2. Imbalance adapt between motor and inverter capacity.</li> </ol>	<ol style="list-style-type: none"> <li>1. Check 3-phase output and output to earth and output to N line;</li> <li>2. Check if inverter capacity adapts to motor.</li> </ol> <p><b>Note; Set FD-21. BIT3=1 can ignore this error, but we don't suggest doing that. Because it has risk to burn module.</b></p>
DF38	165	<b>Imbalance of 3-phase output</b> System find the summation of 3-phase current is not zero and last for certain time.	<ol style="list-style-type: none"> <li>1. The output current feedback way of 3-phase output is seriously abnormal;</li> <li>2. One of 3-phase may short to earth or N line.</li> </ol>	<ol style="list-style-type: none"> <li>1. Check if there is broken circuit or short circuit with N(Neutral) of 3-phase output;</li> <li>2. Feedback channel of current sensor.</li> </ol>
DF39	166	<b>Output voltage is saturated</b> During the operation of the system, the integrated controller output voltage is detected to be saturated.	<ol style="list-style-type: none"> <li>1. Low input voltage;</li> <li>2. Rated motor speed setting is not same with actual speed;</li> <li>3. For geared motor, rated slip is too low or over load.</li> </ol>	<ol style="list-style-type: none"> <li>1. Check DC bus voltage;</li> <li>2. Check if rated RPM is same with nameplate or if bus voltage has been dropped down through monitoring running status;</li> <li>3. Check rated slip for geared motor;</li> <li>4. Check balance factor.</li> </ol>

## 8.4. Motor Initial Angle Tuning Faults

Chart 8.4 Motor Initial Angle Rotation Tuning Fault List

Error Code	Definition	Possible Causes	Possible Solution
RF100	<p><b>Controller fault</b></p> <p>The drive has a failure and cannot do Initial Angle Rotation Tuning.</p>	Controller has met fault.	First solve fault according to error code, then angle tuning again. Refer to <b>Chart 8.3 Driver Fault List</b> .
RF226	<p><b>Give voltage limit</b></p> <p>Already give limit force during angle tuning, but feedback current cannot reach least requirement.</p>	<ol style="list-style-type: none"> <li>1. Incorrect parameters of motor or encoder;</li> <li>2. The difference between the actual parameters of the motor and the estimated parameters of the driver is too large;</li> <li>3. Power matching imbalance between motor and driver (The motor power is far less than the drive).</li> </ol>	<ol style="list-style-type: none"> <li>1. Check parameters of motor and encoder;</li> <li>2. Decrease F5-08 to complete tuning, then recover F5-08;</li> <li>3. Check if the power of inverter is adapted to motor, refer 2.</li> </ol>
RF227	<p><b>Output current over limit</b></p> <p>During the tuning process, the driver controller detects that the output current has reached the limit and stops the output, indicating that the current is out of limit.</p>	<ol style="list-style-type: none"> <li>1. Incorrect parameters of motor or encoder;</li> <li>2. The difference between the actual parameters of the motor and the estimated parameters of the driver is too large;</li> <li>3. Power matching imbalance between motor and driver (The motor power is far more than the drive).</li> </ol>	<ol style="list-style-type: none"> <li>1. Check parameters of motor and encoder;</li> <li>2. Increase F5-08 to complete tuning, then recover F5-08;</li> <li>3. Check if the power of inverter is adapted to motor, refer 2.</li> </ol>
RF228	<p><b>ESC input</b></p> <p>During the tuning process, ESC input is effective, and self-tuning is cancelled.</p>	The hand operator triggers the ESC button to cancel angle tuning.	Angle tuning interruption, failure to complete, please do angle tuning again.
RF229	<p><b>Over time at zero speed</b></p> <p>In the process of tuning, when the rotor is positioned, the feedback speed is not zero for a long time, and it cannot locate accurately.</p>	<ol style="list-style-type: none"> <li>1. Motor carrying partial load;</li> <li>2. Bad feedback speed of encoder.</li> </ol>	<ol style="list-style-type: none"> <li>1. Ensure brake is off;</li> <li>2. Remove interference of encoder.</li> </ol>

Chart 8.4 Motor Initial Angle Rotation Tuning Fault List (Cont'd)

Error Code	Definition	Possible Causes	Possible Solution
RF230	<b>Current detection error</b> During the tuning process, the feedback current value ultra-lower limit and the self-tuning condition is not satisfied.	<ol style="list-style-type: none"> <li>1. Broken circuit at load side or lack of phase;</li> <li>2. Imbalance phase of motor side or rated current wrongly set;</li> <li>3. Inverter cannot adapt to motor. (Motor capacity is highly lower than inverter)</li> </ol>	<ol style="list-style-type: none"> <li>1. Ensure 3-phase connection to motor;</li> <li>2. Ensure motor parameters setting;</li> <li>3. Ensure motor should adapt to inverter.</li> </ol>
RF231	<b>CD signals of encoder is abnormal</b> In the process of tuning, it is found that CD feedback position value is abnormal, and it is impossible to identify the CD line sequence.	<ol style="list-style-type: none"> <li>1. Parameters of motor or encoder have been wrongly input;</li> <li>2. Interference in encoder;</li> <li>3. Error input of motor or encoder;</li> <li>4. Wrong PG type set.</li> </ol>	<ol style="list-style-type: none"> <li>1. Check CD signals wiring;</li> <li>2. Remove interference;</li> <li>3. Verify parameters of motor and encoder;</li> <li>4. Check PG type set.</li> </ol>
RF232	<b>Motor does not rotate</b> In the process of tuning, the driver cannot control the normal rotation of the motor.	<ol style="list-style-type: none"> <li>1. Encoder connection fault, no feedback speed;</li> <li>2. Motor has load or brake close;</li> <li>3. The power difference between the motor and the driver is too large and does not match.</li> </ol>	<ol style="list-style-type: none"> <li>1. Check encoder A&amp;B signal connection, elimination of encoder signal interference;</li> <li>2. Make sure motor has no load &amp; brake open;</li> <li>3. Check the parameters of the number of the motor and the number of the encoder;</li> <li>4. Detection of power matching of motor and driver controller, reduce the rated current [F5-08], and resume F5-08 after tuning.</li> </ol>
RF233	<b>Motor rotates in wrong direction</b> In the process of tuning, the direction of the motor is not consistent with the control direction, and there is a reverse rotation.	Motor phase sequences does not match encoder.	<ol style="list-style-type: none"> <li>1. Adjust motor phase sequence;</li> <li>2. Adjust encoder A-, A+ or B-, B+.</li> </ol>
RF234	<b>Encoder R pulse signal error</b> R pulse signal was not detected for a long time in the process of tuning.	<ol style="list-style-type: none"> <li>1. No detection of R pulse signal;</li> <li>2. Interference of encoder signal;</li> <li>3. Error input of motor or encoder;</li> <li>4. In the course of tuning, the motor is rotated in distress.</li> </ol>	<ol style="list-style-type: none"> <li>1. Check wiring for R pulse signal;</li> <li>2. Elimination of encoder signal interference;</li> <li>3. Verifying the number of motor poles and the number of encoder lines;</li> <li>4. Open or close the brake in the process of self-learning.</li> </ol>

Chart 8.5 Motor Initial Angle Static Tuning Fault List

Error Code	Definition	Possible Causes	Possible Solution
RF100	<b>Controller fault</b> The drive has fault and cannot do tuning.	Controller has met fault	First solve fault according to error code, then angle tuning again. Refer to <b>Chart 8.3 Driver Fault List</b> .
RF226	<b>Give voltage limit</b> Already give limit force during angle tuning, but feedback current cannot reach least requirement.	<ol style="list-style-type: none"> <li>1. Incorrect parameters of motor or encoder;</li> <li>2. The difference between the actual parameters of the motor and the estimated parameters of the driver is too large;</li> <li>3. Power matching imbalance between motor and driver (The motor power is far less than the drive).</li> </ol>	<ol style="list-style-type: none"> <li>1. Check parameters of motor and encoder;</li> <li>2. Decrease F5-08 to complete tuning, then recover F5-08;</li> <li>3. Check if the power of inverter is adapted to motor, refer 2.</li> </ol>
RF227	<b>Output current over limit</b> During the tuning process, the driver controller detects that the output current has reached the limit and stops the output, indicating that the current is out of limit.	<ol style="list-style-type: none"> <li>1. Incorrect parameters of motor or encoder;</li> <li>2. The difference between the actual parameters of the motor and the estimated parameters of the driver is too large;</li> <li>3. Power matching imbalance between motor and driver (The motor power is far more than the drive).</li> </ol>	<ol style="list-style-type: none"> <li>1. Check parameters of motor and encoder;</li> <li>2. Increase F5-08 to complete tuning, then recover F5-08;</li> <li>3. Check if the power of inverter is adapted to motor, refer 2.</li> </ol>
RF228	<b>ESC input</b> During the tuning process, ESC input is effective, and self-tuning is cancelled.	<ol style="list-style-type: none"> <li>1. Release Up or Down button while tuning;</li> <li>2. Fault occurs during angle tuning.</li> </ol>	<ol style="list-style-type: none"> <li>1. Angle tuning interruption, failure to complete, please do angle tuning again. Do not forced to run, there is a danger of losing control.</li> <li>2. Check whether there is elevator logic fault, resulting in stop tuning. Refer to <b>Chart 8.1 Elevator System Faults List</b>.</li> </ol>
RF229	<b>Over time at zero speed</b> Over time at zero speed Before start, feedback speed is not zero for a long time	<ol style="list-style-type: none"> <li>1. Brake open or brake force is not enough;</li> <li>2. There's interference in encoder.</li> </ol>	<ol style="list-style-type: none"> <li>1. Ensure brake is off;</li> <li>2. Remove interference of encoder.</li> </ol>

Chart 8.5 Motor Initial Angle Static Tuning Fault List (Cont'd)

Error Code	Definition	Possible Causes	Possible Solution
RF230	<b>Current detection error</b> During the tuning process, the feedback current value ultra-lower limit and the self-tuning condition is not satisfied.	<ol style="list-style-type: none"> <li>1. Broken circuit at load side or lack of phase;</li> <li>2. Imbalance phase of motor side or rated current wrongly set;</li> <li>3. Inverter cannot adapt to motor. (Motor capacity is highly lower than inverter)</li> </ol>	<ol style="list-style-type: none"> <li>1. Ensure 3-phase connection to motor;</li> <li>2. Ensure motor parameters setting;</li> <li>3. Ensure motor should adapt to inverter.</li> </ol>
RF231	<b>CD signals of encoder is abnormal</b> In the process of tuning, it is found that CD feedback position value is abnormal, and it is impossible to identify the CD line sequence.	<ol style="list-style-type: none"> <li>1. Parameters of motor or encoder have been wrongly input;</li> <li>2. Interference in encoder;</li> <li>3. Error input of motor or encoder;</li> <li>4. Wrong PG type set.</li> </ol>	<ol style="list-style-type: none"> <li>1. Check CD signals wiring;</li> <li>2. Remove interference;</li> <li>3. Verify parameters of motor and encoder;</li> <li>4. Check PG type set.</li> </ol>
RF237	<b>Motor moved while static angle calculation</b> When the motor angle position is inferred static, the motor cannot rotate to obtain the determined current position.	<ol style="list-style-type: none"> <li>1. Brake open or brake force is not enough;</li> <li>2. Bad encoder wire or interference in encoder.</li> </ol>	<ol style="list-style-type: none"> <li>1. Ensure brake is closed;</li> <li>2. Check encoder A, B signals, remove interference</li> </ol>
PF238	<b>Detection current is too small</b> In the Initial angle static tuning process, the output current value is lower than the lower limit, and the tuning condition is not satisfied.	<ol style="list-style-type: none"> <li>1. The rated current of the motor may not be in conformity with the actual motor;</li> <li>2. Motor/Controller connection is incorrect. (Break circuit or phase lost)</li> </ol>	<ol style="list-style-type: none"> <li>1. Check motor/controller connection;</li> <li>2. Check rated current and rated power of motor.</li> </ol>
PF239	<b>Encoder R pulse signal lost</b> No encoder R pulse signal detected after motor tuning for 10s	<ol style="list-style-type: none"> <li>1. Interference in R pulse signal;</li> <li>2. A &amp; B signals connection error;</li> <li>3. Inspection elevator speed setting is too low.</li> </ol>	<ol style="list-style-type: none"> <li>1. Check the encoder wiring;</li> <li>2. Remove the encoder interference;</li> <li>3. Ensure the normal operation of the motor;</li> <li>4. Inspection elevator speed setting is too low.</li> </ol>
RF252	<b>While static angle tuning, motor speed is over proof</b>	During static angle tuning, after initial location, motor need to rotate for 3 rounds. During rotating, system give out speed but receive no feedback and the lasting time of this status has been over limit. Then system announce error.	<ol style="list-style-type: none"> <li>1. Check if there is feedback from SIN/COS encoder;</li> <li>2. Check the phase of power input.</li> </ol>

Note; 1. Above description is for SIN/COS encoder;

2. For increment encoder, RF231 correspond to UVW signals, RF234 and RF239 correspond to Z pulse. The solution is same, and other faults are same too.

## 8.5. Motor Parameters Tuning Faults

Motor parameters tuning error code and their possible causes and solution are shown below in Chart 8.6 and Chart 8.7. (Including rotation and static parameters tuning)

**Chart 8.6 Motor Parameters Rotation Tuning Fault List**

Error Code	Definition	Possible Causes	Possible Solution
PF2	Motor parameter input incorrect or no input.	1. Motor parameter input error; 2. Motor/Controller connection error.	1. Check motor parameters; 2. Check motor/controller connection.
PF3	Motor resistor tuning result error.	1. Input motor data is incorrect; 2. Wire not secured on terminal block.	1. Check input parameters; 2. Check the motor wiring and secured them on terminal block.
PF4	Motor leakage inductance tuning result error	1. Input motor data is incorrect; 2. Motor tuning with load.	1. Check the input parameters; 2. Make sure motor has no load.
PF5	Motor does not rotate in auto tuning.	1. Motor parameter input incorrect; 2. Wire loose on terminal block; 3. PG card damaged or wiring incorrect.	1. Check the input parameters; 2. Secure the wire on terminal block; 3. Check PG card and its wiring.
PF6	Motor cannot reach rated speed or rotate direction error.	1. Input motor data incorrect; 2. Motor input phase incorrect; 3. Encoder /PG card /wiring error.	1. Check the input parameters; 2. Check motor input phase; 3. Check encoder, PG card and wiring
PF7	No-Load Current error	Auto tuning motor with loads	Make sure the motor has no load.

**Chart 8.7 Motor Parameter Static Tuning Fault List**

Error Code	Definition	Possible Causes	Possible Solution
PF2	Initial fault	1. Motor parameters input incorrect; 2. Motor/Controller connection error.	1. Input correct motor parameters; 2. Check motor/controller connection.
PF3	Motor resistor tuning result error.	1. Input motor data is incorrect; 2. Wire not secured on terminal block.	1. Check input parameters; 2. Check the motor wiring and secured them on terminal block.
PF4	Motor leakage inductance tuning result error	1. Input motor data is incorrect; 2. Motor/Controller connection error.	1. Check input parameters; 2. Check motor/controller connection.
PF237	Motor is not held still at initial tuning period.	Motor brake is not close, or brake is too loose, causing sheave to move during initial tuning period	Make sure motor brake is tightly closed.
PF238	Current too small at initial tuning period.	Motor/Controller connection error.	Check motor/controller connection.

## Chapter 9 Maintenance

This chapter describes precautions and notes for drive storage and maintenance.

### 9.1. Safety Precautions for Drive Maintenance & Storage

#### Danger

- ◇ There are high voltage terminals in integrated controller, please DO NOT TOUCH.  
Otherwise there has potential risk of electric shock.
- ◇ Make sure to install front protection cover before power on integrated controller and cut power before removing the front protection cover.  
Otherwise there has potential risk of electric shock.
- ◇ Before open case service/maintenance, make sure the power is cut for 10 minutes, power on LED (CL) is off and DC+/- bus voltage is lower than 24V.  
Otherwise there has potential risk of electric shock due to capacitor remain voltage.
- ◇ Only authorized and qualified personnel are allowed to inspect/service integrated controller.  
Otherwise there has potential risk of electric shock and damage the product.
- ◇ Before maintenance, technicians must remove any metal objects (watch, ring, etc.), and must wear cloth with qualified isolation level.  
Otherwise there has potential risk of electric shock.
- ◇ DO NOT remove or change terminal ports at controller power on.  
Otherwise there has potential risk of electric shock.
- ◇ DO NOT change internal structure of the integrated controller.  
Otherwise there has potential risk of electric shock and damage the product.
- ◇ After maintenance, please make sure all terminals and contactors are tightly secured.  
Otherwise there has potential risk of controller not functioning or even get damaged.

#### Attention

- ◇ CMOS integrated circuits are applied in control board, please be aware.  
If touch by hand directly, the control board may get damaged due to static charge.

## 9.2. Daily Check

In order to increase the life time of controller and make sure the safety operation of elevator, it is necessary to check and inspect controller in a daily basis. As it is not allowed to remove the controller front cover with controller power on, the controller can check by observing the device external condition, including;

1. Check if fan is working properly, including any abnormal noise.
2. Check if the LED indicator and digital operator of controller is working properly.
3. Check if there are any abnormal noise, vibration or smell.
4. Check thermal condition of controller and motor.
5. Check the ambient environment (Temperature  $-10\sim 45^{\circ}\text{C}$ , humidity  $5\sim 95\%RH$ , no frozen, no oil mist or powder in air)
6. Check if the comfort level of elevator has decreased dramatically.
7. Check if the input power and frequency are within rated range.

## 9.3. Routine Inspection

In order to increase the life time of controller and make sure the safety operation of elevator, it is necessary to check and inspect controller in a routine basis. At routine check, first switch elevator to inspection mode, stop elevator operation and cut system power. Then please perform inspections procedures based on Chart 9.1, following safety precautions and notes mentioned above.

**Chart 9.1 Routine Inspection Check List**

Check Item	Definition	Possible Solution for fault
Terminal, connector, screws	Check for loose screws/bolts	Tighten the loose screws/bolts
	Check for loose connector	Reconnect the loose connector
Heat sink & Wind tunnel	Check for dust or any blockage.	Use dry air gun (0.4-0.6MPa) to clean dust, use proper tools to remove other attached objects.
PCBs	Check for dust, oil (conducting).	Use dry air gun (0.4-0.6MPa) to clean dust, use proper tools to remove other attached objects, replace PCB if necessary.
Cooling Fan	1. Abnormal noise & vibration 2. Color/shape change due to heat 3. Loose bolts, screws.	For 1,2; Change fan; For 3; Tighten screws.
Power device	Check for dust	Use dry air gun (0.4-0.6MPa) to clean dust or other objects.
Capacitor	Check for color, smell	Change controller or capacitor if necessary.

## 9.4. Quick Wear parts

Controller is made from many components inside, all these parts have their lifetimes, and they depend on environment and working condition. As a result, in order to increase the life time of controller and make sure the safety operation of elevator, it is necessary to check and inspect some of these parts in a regular basis, replace them if needed. Chart 9.2 below is the components change standard.

**Chart 9.2 Component change standard**

Item	Life time	Change method
Cooling Fan	2-3 year (20000hrs)	Change new fan
Main circuit capacitor	5 year	Change new capacitor (Decide after inspection)
Main circuit fuse	10 year	Change new fuse
Capacitors on PCB	5 year	Change new PCB (Decide after inspection)
Other components	-----	Decide after inspection

Note; Conditions below are required in order for components to reach life time mentioned above.

Ambient temperature; Average 30C around one year

Load rate; Average below 80%

Running rate; Daily usage time <12 hrs.

## 9.5. Warranty

Integrated controller warranty period is 18 months after manufacturer (based on product name plate). However, even within the 18-month warranty period, repair cost will be charged in the following cases;

1. Damage caused by miss-operation – not following manual guidance
2. Damage due to use outside rated range
3. Damage due to abnormal application of the drive
4. Damage due to natural environment, such as fire, flood, earthquake etc.

## Chapter 10 Controller installation with EMC Standard

This chapter explains in detail the integrated controller installation with EMC standard for reference.

### 10.1. EMC Briefing

EMC (short for Electromagnetic Compatibility) refers to the device/system capability to function normally in an environment with electromagnetic interference. It has two parts; first, the device/system must be able to work normally in environment with electromagnetic interference. Then, the electromagnetic interference it generated must be within a certain level so it will not affect other devices/systems in the environment.

### 10.2. EMC Characteristics of Integrated Controller

Same as other electronic devices, the integrated controller is affected by electromagnetic interference and at the same time it is also a source of electromagnetic interference. In order to enable the controller work normally in an electromagnetic environment, at the same time not to affect other devices, it is specially designed to deal with EMC characteristics shown below.

1. Input current is non-sine wave, with high frequency, this will cause strong electromagnetic interference.
2. Output voltage is high frequency PWM wave, this will cause strong electromagnetic interference.
3. As electromagnetic receiver, if controller receives too strong interference, it may not work properly.
4. Reduce controller generated electromagnetic interference will increase its own EMC level.

### 10.3. EMC Installation Guide

As determined by operating principle, the elevator integrated controller produces certain noises during operation. The effect of noise on peripheral equipment is relevant to the noise type, transmission path as well as the design, installation, wiring and grounding of drive system.

#### 10.3.1 Noise Control

Basic strategy for noise control is to cut the transmission channel between noise source and noise receiver. Detail solutions are shown below;

1. Power cable and signal cable should be lay out separately and stay as far as possible, make sure to avoid two kind of cables stay in parallel or tied together. When meet situations in which signal cable must pass power cable, make sure two cables stay in perpendicular crossing and stay as far as possible.
2. All controller signal cable must have net shield, and the shield should be grounded at the controller side, with grounding area as large as possible.
3. For signal cables easy to get interference, such as encoder cable, it should have double twist shield cover, with grounding area as large as possible. One suggestion is to put the cable in metal tube or in an individual metal cable tunnel with reliable grounding condition.

4. Power cable and motor cable should use power cable with armor cover or shield. Power cable should use individual metal cable tunnel with reliable grounding point at controller side. Motor cable should follow the same grounding principle and its shield should also connect to motor cover at motor side.
5. Power cable should be connected to inverter use RFI filter or output reactor. Motor cable should be connected with output filter (sine/cosine filter) or install output reactor. Another solution is to surround motor cable twice with ferrite magnetic circle.
6. Other devices that are easy to get interference should be put far away from the controller and power cable.
7. Inductive devices around controller such as contactor, relay, brake unit, their coil need to install surge controller (such as RC filter, resistor or freewheeling diode).

### 10.3.2 Wiring

#### 1. Wiring in Control Cabinet

- 1) Inside control cabinet, signal cable and power cable should be placed in different area, with minimum distance of 20cm. DO NOT put two kinds of cables in parallel or tied together. If must cross two cable, they must remain strictly perpendicular with each other.
- 2) The input (power) and output (motor) of power cable cannot cross or tied together, especial when the cable is connected with input/output filter.
- 3) Inductive devices inside control cabinet (such as contactor, relay, brake unit), their coil need to install surge controller (such as RC filter, resistor or freewheeling diode).
- 4) Both signal and power cable should have net shield/armor with high frequency low impedance.
- 5) Cable shield should ground with large area.

#### 2. Wiring at site

- 1) Power cable must have 5 wires, including U/V/W, one for ground and one for neutral, DO NOT mix use.
- 2) At site, signal cable and power cable should be placed in different area, with minimum distance of 20cm. DO NOT put two kinds of cables in parallel or tied together. If must cross two cable, they must remain strictly perpendicular with each other.
- 3) Signal cables must have net shield, the shield should be grounded at controller side with large ground area.
- 4) Power cable and motor cable should use power cable with armor cover or shield. Power cable should use individual metal cable tunnel with reliable grounding point at controller side. Motor cable should follow the same grounding principle and its shield should also connect to motor cover at motor side.

### 10.3.3 Ground Connection

Controller must be connected to the ground at work, grounding helps to solve the EMC issue, at the same time it brings safety to the device and people. Ground correctly is the most important (and most reliable/economic) solution to EMC issue, and it should be considered first. Notes for ground connections are shown below;

1. Control cabinet must have GND public terminal (copper plate).

2. The case of control cabinet must be connected to the ground public terminal. This connection can be made between cabin door and ground public terminal copper plate (width >15mm).
3. All ground connection must remain complete on both sides, cannot connect two grounding wire in the middle.
4. The ground of integrated controller must be connected to the ground public terminal.
5. Power cable, motor cable and brake resistor cable (if necessary) shield/armor must be connected to the ground public terminal.
6. The distance from cable shield to ground public terminal should be <50mm.
7. Ground connection wire should have low impedance (large cross-sectional area and short in length).
8. Power cable should have 5 cores (U, V, W, neutral & ground) with shield, motor cable should have 4 cores (U, V, W, ground) with shield. For motor cable ground wire, one terminal should be grounded at controller side, another terminal should be grounded at motor side.

#### 10.3.4 Leakage Current

Leakage current happens between wire and to ground, it depends on wire capacitance and controller carrier frequency. Leakage between wire is related to wire capacitance between controller input (power cable) and output (motor cable), controller carrier frequency, motor/power cable cross sectional area and length, while leakage current to ground is located at ground public terminal, it will get into the system and (in some case) affect other electrical devices through ground connection.

Countermeasure for leakage current;

1. Reduce controller carrier frequency;
2. Keep the power and motor cable as short as possible;
3. Power and motor cable cross sectional area should not be too big;
4. For long motor cable (>50m), controller output should have filter or reactor;
5. Should equip inverter use leakage current circuit break.

#### 10.3.5 Power Line Filter

The power line filter is two-way low pass filter which only permits flowing of DC current or 50HZ operating frequency AC current but stops flowing of higher frequency electromagnetic interference current. Therefore, it cannot only inhibit the equipment's electromagnetic interferences flowing into power line but also inhibit the noises in power line flowing into equipment.

Precautions for Installation of Power Line Filter;

1. In the cabinet, the filter should be located close to the power line inlet as practicably as possible. Additionally, the filter supply line section left in the control cabinet must be as short as possible.

2. The power line filter should be grounded with reliable connection, and the grounding area should be as large as possible.
3. The power line filter metal case should be securely attached to the control cabinet plate, with contacting area as large as possible and ensure good electrical connection.
4. Please use power line filter that matches the system, such as inverter use power line RFI filter.

#### **10.4. EMC standard satisfied by Integrated Controller**

When install integrated controller and EMI filter, if the installation procedures are following EMC installation guide, then the system could meet the standards below;

EN61000-6-4:EMC test in Industrial Environment 1800-3.

EN61800-3:EMC Standard (2nd Level Environment)

EN61000-6-3:EMC Standard (Residential Environment)

EN61000-6-4:EMC Standard (Industrial Environment)

## Chapter 11 Accessories

### 11.1. iBL6-KIO-V6.2 Cabinet Interface Board

The control cabinet interface board provides users with solidified interface to facilitate user connection. Users can use our integrated control cabinet, and only need to configure peripheral cables. We can also produce all cables according to the schematic diagram provided by our company.

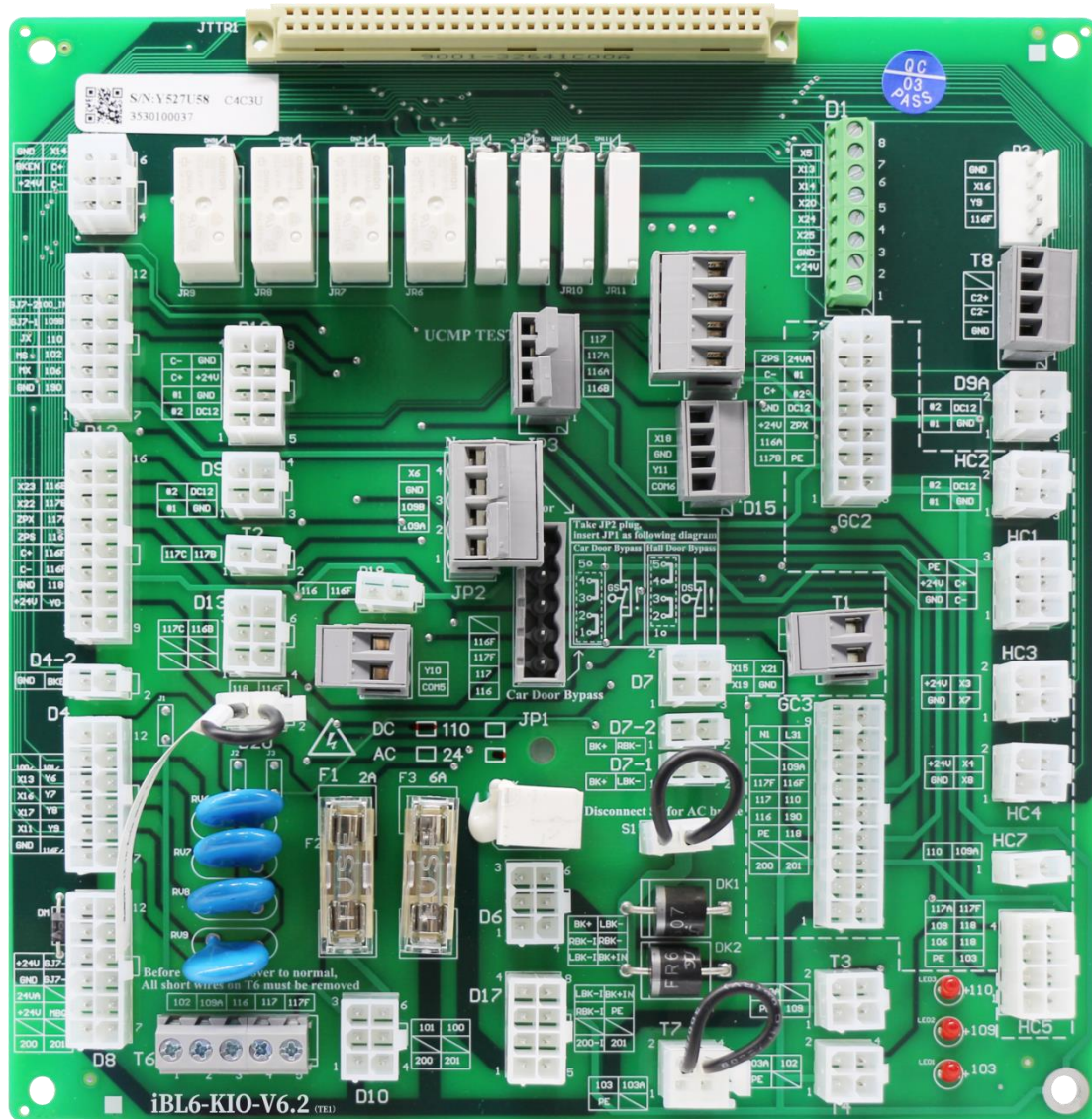

Figure 11.1 iBL6-KIO-V6.2 Control cabinet interface board physical map

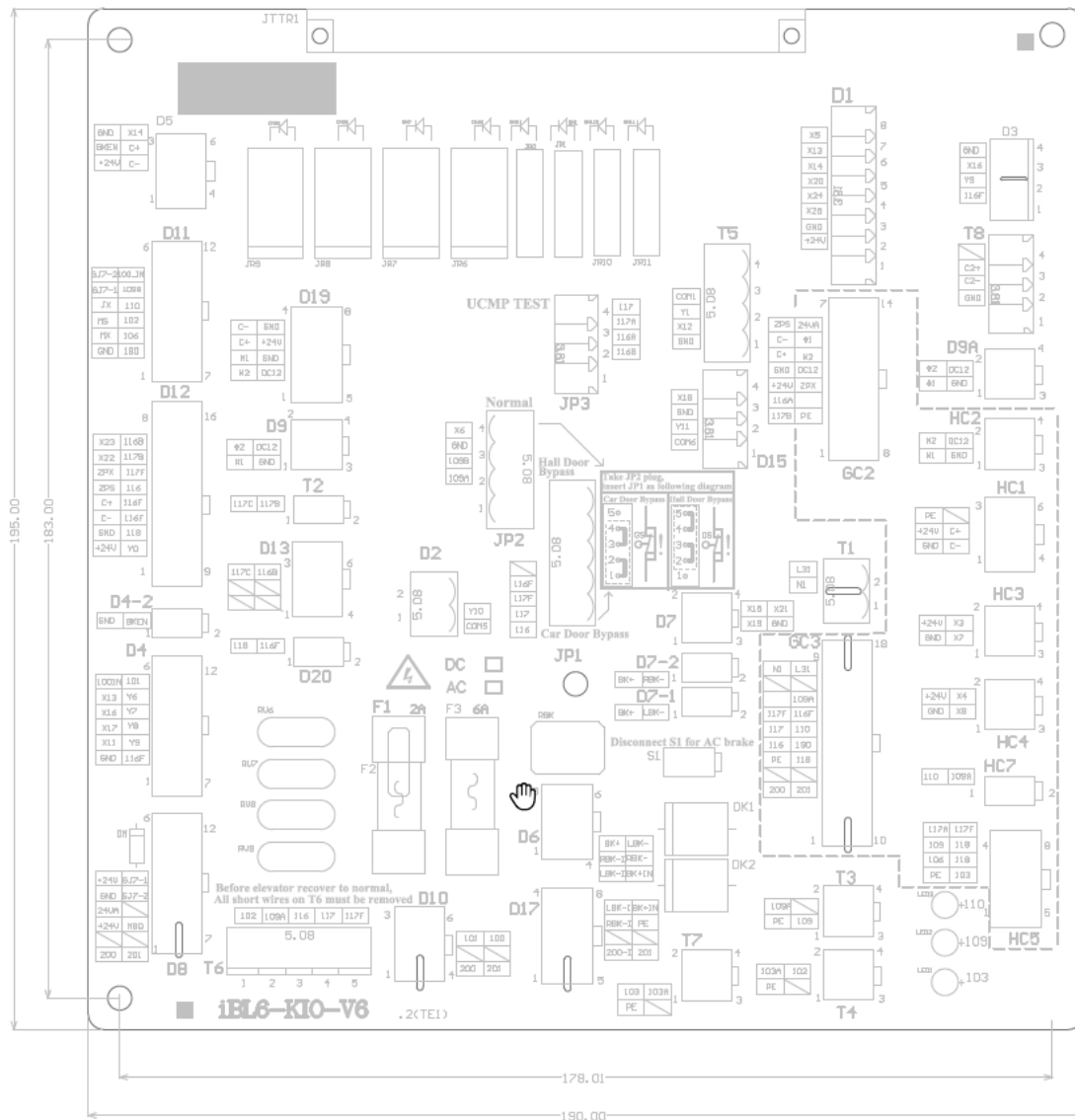

Figure 11.2 iBL6-KIO-V6.2 device position and size diagram of the control cabinet interface board

Table 11.1 Interface Description of Interface Board - Internal Wiring of Control Cabinet

Terminal	Port	Signal	Function
D1		D1-1 +24V	DC +24V output(power for rope head weighting device)
		D1-2 GND	Signal ground (0V)
		D1-3 X25	Spare (or Overload of rope head)
		D1-4 X24	Spare (or Full load of rope head)
		D1-5 X20	Spare (or Parallel electric lock)
		D1-6 X14	Spare
		D1-7 X13	Spare
		D1-8 X5	Spare (or Maintenance and operation)
D2		D2-1 COM5	Spare output Y10-COM
		D2-2 Y10	Spare output Y10

Table 11.1 Interface Description of Interface Board - Internal Wiring of Control Cabinet(Cont'd)

Terminal	Port	Signal	Function
<b>D3</b>		D3-1 116	Y6~Y9 Output public terminal(Door lock circuit ending point)
		D3-2 Y6	STO Control output (Y9 output)
		D3-3 X16	STO Input (feedback) signal
		D3-4 GND	Input (feedback) signal ground
<b>D4</b>		D4-1 GND	Input (feedback) signal ground
		D4-2 X11	Star-sealed contactor feedback input signal
		D4-3 X17	Brake contactor feedback input signal
		D4-4 X16	Running contactor feedback input signal
		D4-5 X13	Economic resistor contactor feedback input signal
		D4-6 100	AC110V+(Used for star-sealed contactor)
		D4-7 116F	Y6~Y9 Output public terminal(End of door lock circuit)
		D4-8 Y9	Running contactor coil -(Y9 output)
		D4-9 Y8	star-sealed contactor coil-(Y8output)
		D4-10 Y7	Brake contactor coil-(Y7output)
		D4-11 Y6	Economic resistance contactor coil-(Y6 output)
		D4-12 101	AC110V-
<b>D5</b>		D5-1 +24	DC +24V Input(From the brake board)
		D5-2 Spare	Spare
		D5-3 GND	DC 0V Input(From the brake board)
		D5-4 C-	CAN COM CANL(For brake board)
		D5-5 C+	CAN COM CANH(For brake board)
		D5-6 Spare	Spare
<b>D6</b>		D6-1 LBK-IN	DC110V-(connect brake coil)
		D6-2 RBK-IN	DC110V-(connect brake coil)
		D6-3 BK+	DC110V+(Contactor contact return)
		D6-4 BK+IN	DC110V+(Output to contactor contacts)
		D6-5 RBK-	DC110V-(Contactor contact return)
		D6-6 LBK-	DC110V-(Contactor contact return)
<b>D7</b>		D7-1 X19	Brake arm micro switch feedback 2(right)
		D7-2 X15	Brake arm micro switch feedback 1(left)
		D7-3 GND	Input (feedback) signal ground
		D7-4 X21	Feedback input of thermosensitive switch
<b>D7-1</b>		D7-1-1 BK+	DC110V+(connect left brake coil)
		D7-1-2 LBK-	DC110V-(connect left brake coil)
<b>D7-2</b>		D7-2-1 BK+	DC110V+(connect right brake coil)
		D7-2-2 RBK-	DC110V-(connect right brake coil)

Chart 11.1 iBL6-KIO-V6.2 interface description - internal wiring(Cont'd)

Terminal	Port	Signal	Function
D8		D8-1 200	AC 220V-L(For EPD)
		D8-2 Spare	Spare
		D8-3 +24V	DC +24V
		D8-4 GND3	DC 0V(For EPD Door zone indicator)
		D8-5 GND	DC 0V
		D8-6 +24V	DC +24V
		D8-7 201	AC 220V-N(For EPD)
		D8-8 Spare	Spare
		D8-9 MBQ	Door zone indicator(Return to the upper security door zone)
		D8-10 Spare	Spare
		D8-11 GJ7-2	Output of INS. Switch contact (For EPD)
		D8-12 GJ7-1	Output of INS. Switch contact (For EPD)
D9		D9-1 #1	Five party intercom #1(connect machine room interphone)
		D9-2 #2	Five party intercom #2(connect machine room interphone)
		D9-3 GND	Five party intercom power supply ground(0V)
		D9-4 DC12	Five party intercom DC12V power supply
D10		D10-1 200	AC 220V-L(For safety circuit transformers)
		D10-2 Spare	Spare
		D10-3 101	Transformers AC110V-(Input)
		D10-4 201	AC 220V-N(For safety circuit transformers)
		D10-5 Spare	Spare
		D10-6 100	Transformers AC110V+(Input)
D11		D11-1 130	The middle point of the control cabinet inspection and the car top inspection
		D11-2 X2	Down running input (Inspection)
		D11-3 X1	Up running input (Inspection)
		D11-4 JX	Inspection input(Overhaul switch of control cabinet to 130)
		D11-5 GJ7-2	Input of INS. Switch contact (For EPD)
		D11-6 GJ7-1	Input of INS. Switch contact (For EPD)
		D11-7 190	Control cabinet emergency electric operation switch N (bypass)
		D11-8 106	Control cabinet emergency electric operation switch L (bypass)
		D11-9 102	Control cabinet emergency stop switch N
		D11-10 110	Safety circuit(Ins. Switch)
		D11-11 109B	Safety circuit(Ins. Switch)
		D11-12 100_IN	Control cabinet emergency stop switch L

Chart 11.1 iBL6-KIO-V6.2 interface description - internal wiring(Cont'd)

Terminal	Port	Signal	Function
D12		D12-1 +24V	DC +24V output(Power supply for re-leveling board)
		D12-2 GND	DC 0V output(Power supply for re-leveling board)
		D12-3 C-	CAN COM CANL(For re-leveling plate)
		D12-4 C+	CAN COM CANH(For re-leveling plate)
		D12-5 ZPS	Up door area re-leveling input signal
		D12-6 ZPX	Down door area re-leveling input signal
		D12-7 X22	Re-leveling condition input
		D12-8 X23	Re-leveling sensor input
		D12-9 Y0	Re-leveling control output
		D12-10 118	The middle point of the front side door and the rear side door
		D12-11 116F	Door lock circuit- (Including front and rear side hall/car door)
		D12-12 116F	Door lock circuit- (Including front and rear side hall/car door)
		D12-13 116	Door lock circuit+ (Including front and rear side hall/car door)
		D12-14 117F	Safety circuit(Rear hall door circuit ending point)
		D12-15 117B	Re-leveling board short car door auxiliary lock-
		D12-16 116B	Re-leveling board short car door auxiliary lock+
D13		D13-1 Spare	Spare
		D13-2 Spare	Spare
		D13-3 117C	Power input of additional brake+
		D13-4 Spare	Spare
		D13-5 Spare	Spare
		D13-6 116B	Power input of additional brake-
D15		D15-1 COM6	UPS out of power output public terminal
		D15-2 Y11	UPS output
		D15-3 GND	Input signal ground
		D15-4 X18	Power outage emergency operation input signal
D17		D17-1 200	AC220V input L(From overvoltage protective board)
		D17-2 Spare	Spare
		D17-3 RBK-IN	DC110V-(Right brake power input -)
		D17-4 LKB-IN	DC110V-(Left brake power input -)
		D17-5 201	AC220V input N(From overvoltage protective board)
		D17-6 Spare	Spare
		D17-7 PE	Shielding layer
		D17-8 BK+IN	DC110V+(Brake power input +)
D19		D19-1 #1	Five party intercom #1(connect machine room interphone)
		D19-2 #2	Five party intercom #2(connect machine room interphone)
		D19-3 C+	CAN COM CANH(TWCR)
		D19-4 C-	CAN COM CANL(TWCR)
		D19-5 DC12	Pit five party intercom power DC +12V
		D19-6 GND	Pit five party intercom power 0V
		D19-7 DC24	DC +24V output (TWCR)
		D19-8 GND	DC 0V output (TWCR)

Chart 11.2 iBL6-KIO-V6.2 interface description - machine room wiring

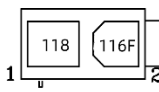
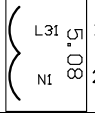
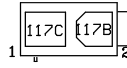
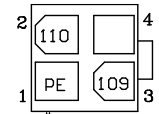
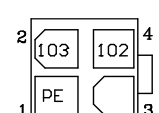
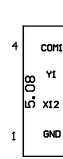
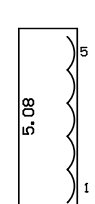
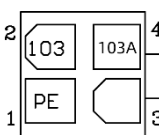
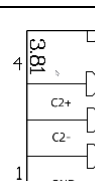
Terminal	Port	Signal	Function
D20		D20-1 118	The middle point of the front side door and the rear side door.
		D20-2 116	Safety circuit(Return point of car door lock circuit)
T1		T1-1 L31	Lighting power input L(transfer traveling cable)
		T1-2 N1	Lighting power input N(transfer traveling cable)
T2		T2-1 117C	Power input of additional brake+
		T2-2 117B	Power input of additional brake-
T3		T3-1 PE	Shielding layer
		T3-2 109A	Machine room speed limit switch - (safety circuit)
		T3-3 109	Machine room speed limit switch +(safety circuit)
		T3-4 Spare	Spare
T4		T4-1 PE	Shielding layer
		T4-2 103A	Machine room handwheel switch - (safety circuit)
		T4-3 Spare	Spare
		T4-4 102	Machine room handwheel switch + (safety circuit)
T5		T5-1 GND	Input signal ground
		T5-2 X12	Fire input signal(Parallel)
		T5-3 Y1	Firefighting relay output
		T5-4 COM1	Firefighting relay public terminal
*T6		T6-1 102	Cabinet emergency stop N
		T6-2 109A	Machine room speed governor switch - (safety circuit)
		T6-3 116	Door lock circuit + (contains front, rear hall doors and car doors)
		T6-4 117	X31+
		T6-5 117F	X32+
T7		T7-1 PE	Shielding layer
		T7-2 103	Pit INS. switch(Safety circuit)
		T7-3 Spare	Spare
		T7-4 103A	Pit INS. switch(Safety circuit)
T8		T8-1 Spare	Spare
		T8-2 C2+	CAN2(Parallel group control)COM CANH
		T8-3 C2-	CAN2(Parallel group control)COM CANH
		T8-4 GND	Input signal ground

\*Note:Disconnect all pins at T6 before running elevator in normal operation mode.

Chart 11.3 iBL6-KIO-V6.2 interface description - traveling cable



Terminal	Port	Signal	Function
GC1		GC1-1 BF6	Backup power supply for traveling cable
		GC1-2 BF5	Backup power supply for traveling cable
		GC1-3 BF4	Backup power supply for traveling cable ( <b>*Note; HC6-1 multiplexing with the hoistway cable</b> )
		GC1-4 BF3	Backup power supply for traveling cable ( <b>*Note; HC6-2 multiplexing with the hoistway cable</b> )
GC2		GC2-1 117B	Auxiliary lock switch of car door+
		GC2-2 116A	Auxiliary lock switch of car door-
		GC2-3 +24V	DC +24V output(Power supply to the car top)
		GC2-4 GND	DC 0V output(Power supply to the car top \DC12 common ground)
		GC2-5 C+	CAN COM CANH
		GC2-6 C-	CAN COM CANL
		GC2-7 ZPS	Up door area re-leveling input signal
		GC2-8 PE	ground
		GC2-9 130	Wiring of car top inspection switch
		GC2-10 ZPX	Down door zone re-leveling input signal
		GC2-11 DC12	Five party intercom power DC +12V input (power supply in car top)
		GC2-12 #2	Car top five party intercom #2
		GC2-13 #1	Car top five party intercom #1
		GC2-14 GND3	Up-leveling input signal
GC3		GC3-1 200	Door motor power output AC 220V-L
		GC3-2 Spare	Spare
		GC3-3 PE	Shielding layer
		GC3-4 116	Safety circuit (car top emergency stops; car door lock circuit start points)
		GC3-5 117	Front hall/car door sealed test point
		GC3-6 117F	Rear hall/car door sealed test point
		GC3-7 Spare	Spare
		GC3-8 N1	The lighting power output of the car top(AC 220V-N)
		GC3-9 201	door motor power output AC 220V-N
		GC3-10 Spare	Spare
		GC3-11 118	The middle point of the front side door and the rear side door
		GC3-12 190	Safety circuit (emergency electric operation for car top inspection)
		GC3-13 110	Safety circuit(Safety pliers)
		GC3-14 116F	Safety circuit(Return point of car door lock circuit)
		GC3-15 Spare	Spare
		GC3-16 L31	The lighting power output of the car top(AC 220V-L)

Chart 11.4 iBL6-KIO-V6.2 interface descriptions - hoistway cable

Terminal	Port	Signal	Function
HC1		HC1-1 GND	DC 0V output (Power supply to the call board)
		HC1-2 +24V	DC +24V output (Power supply to the call board)
		HC1-3 PE	Shielding layer
		HC1-4 C-	CAN COM CANL
		HC1-5 C+	CAN COM CANH
		HC1-6 Spare	Spare
HC2		HC2-1 #1	Pit five party intercom #1
		HC2-2 #2	Pit five party intercom #2
		HC2-3 GND	Input signal ground
		HC2-4 DC12	Pit five party intercom #1 power DC +12V output
HC3		HC3-1 GND	Input signal ground
		HC3-2 +24V	DC +24V output
		HC3-3 X7	Top terminal
		HC3-4 X3	Top terminal 2
HC4		HC4-1 GND	Input signal ground
		HC4-2 +24V	DC +24V output
		HC4-3 X8	Bottom terminal
		HC4-4 X4	Bottom terminal 2
HC5		HC5-1 PE	Shielding layer
		HC5-2 106	Safety circuit(Emergency electric operation)
		HC5-3 109	Safety circuit(Emergency electric operation)
		HC5-4 117A	Safety circuit(Front hall door circuit starting point)
		HC5-5 103	Safety circuit(The starting point of the pit emergency stop circuit)
		HC5-6 118	Safety circuit(Front hall door circuit ending point)
		HC5-7 118	Safety circuit(Rear hall door circuit starting point)
		HC5-8 117F	Safety circuit(Rear hall door circuit ending point)
HC6		HC6-1 BF4	Backup power supply for traveling cable( <b>Note; GC1-3 multiplexed with a traveling cable</b> )
		HC6-2 BF3	Backup power supply for traveling cable( <b>Note; GC1-4 multiplexed with a traveling cable</b> )
		HC6-3 BF2	Backup power supply for traveling cable
		HC6-4 BF1	Backup power supply for traveling cable

Chart 11.5 iBL6-KIO-V6.2 interface description - other

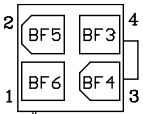
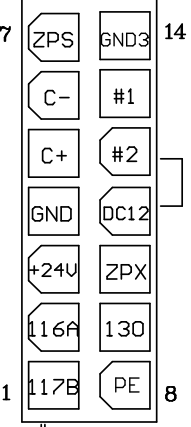
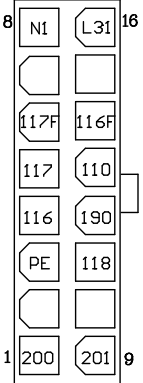
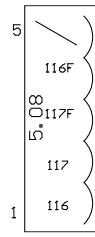
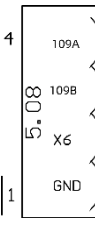
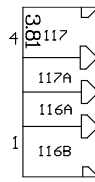
Terminal	Port	Signal	Function
JP1		JP1-1 116	Door lock bypass point( <b>Note; the starting point of the front car door</b> )
		JP1-2 117	Door lock bypass point( <b>Note; the ending point of the front car door, the starting point of the front hall door</b> )
		JP1-3 117F	Door lock bypass point( <b>Note; the ending point of the rear hall door, the starting point of the rear car door</b> )
		JP1-4 116F	Door lock bypass point( <b>Note; the ending point of the rear car door</b> )
		JP1-5 Spare	Spare
JP2		JP2-1 GND	Input signal ground
		JP2-2 X6	Bypass alarm signal input ( <b>* normally closed, disconnected alarm</b> )
		JP2-3 109B	Safety circuit
		JP2-4 109A	Safety circuit( <b>*When bypass Running disconnect the safety circuit, it is necessary to repair the slow up or slow down to effectively restore the safety circuit</b> )
JP3		JP3-1 116B	UCMP test terminal(car auxiliary lock disconnects)
		JP3-2 116A	UCMP test terminal(car auxiliary lock disconnects)
		JP3-3 117A	UCMP test terminal(Hall door lock disconnection)
		JP3-4 117	UCMP test terminal(Hall door lock disconnection)
S5		Jumper 5	A short connection must be used when the serial car top inspection signal is used
JTTR		64PSocket (2.54)	Connect to MU_V61 VL2main board(64P cable)

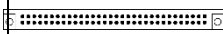
## 11.2. iBL6-DIO-V6.x Car Top Interface Board

The car top interface board solidifies the wiring port of the car top to facilitate the user car-top connection. The user can use our company's car-top inspection box, and only need to configure the peripheral cables. We can also make all the cables according to the schematic diagram provided by our company.

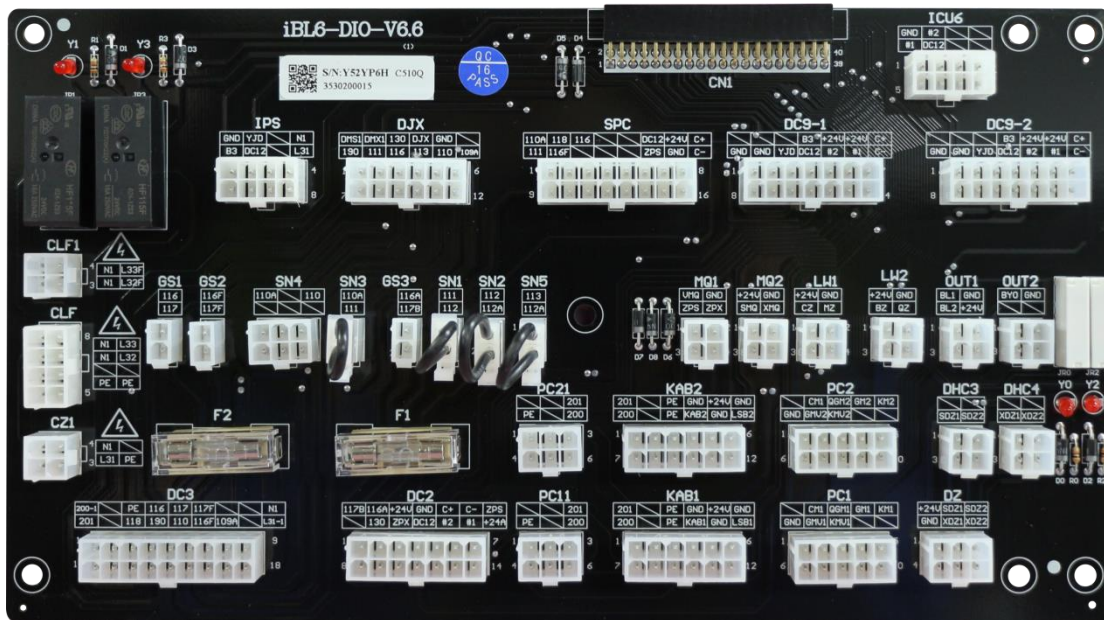

FIGURE 11.3 iBL6-DIO-V6.x car top interface board physical map

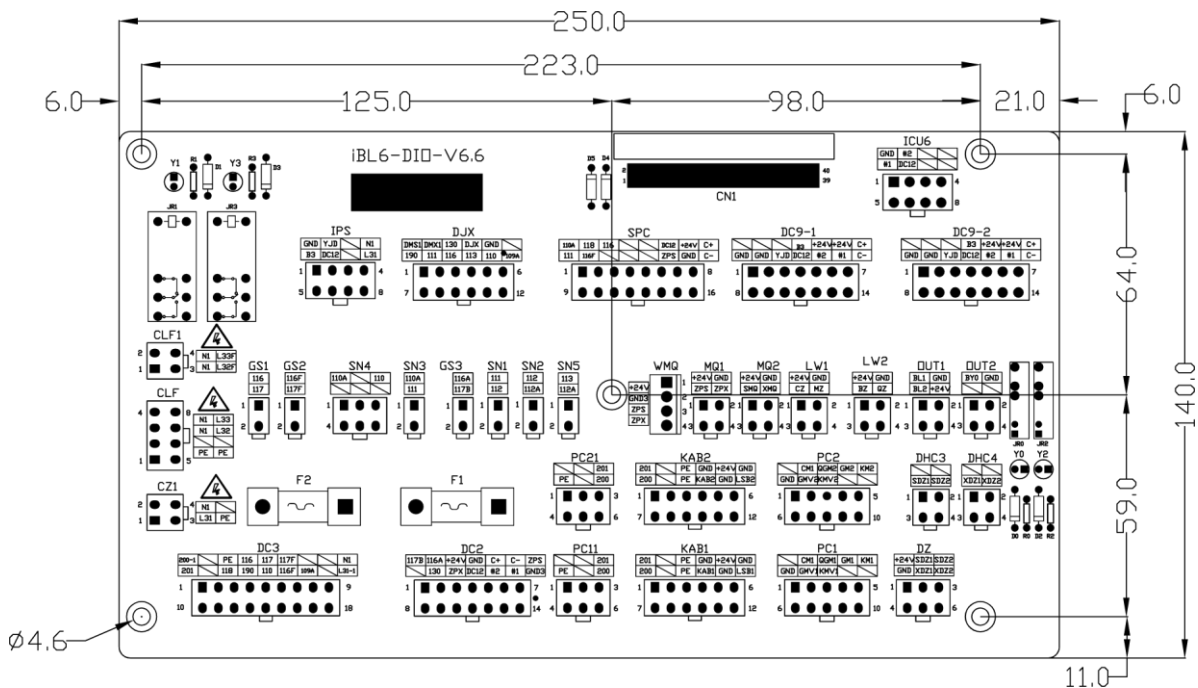

FIGURE 11.4 iBL6-DIO-V6.x device position and size diagram of the car top interface board

Chart 11.6 iBL6-DIO-V6.4 interface description

Terminal	Port	Signal	Function
CLF		CLF-1 PE	Shielding layer
		CLF-3 N1	Car fan AC220V-N
		CLF-4 N1	Car lighting AC220V-N
		CLF-5 PE	Shielding layer
		CLF-7 L32	Car fan AC220V-L (normal close output)
		CLF-8 L33	Car lighting AC220V-L (normal close output)
CLF1		CLF1-1 N1	Car fan AC220V-N
		CLF1-2 N1	Car lighting AC220V-N
		CLF1-3 L32F	Car fan AC220V-L (normal open output)
		CLF1-4 L33F	Car lighting AC220V-L (normal open output)
CZ1		CZ1-1 L31	Car top lighting AC220V-L
		CZ1-2 N1	Car top lighting AC220V-N
		CZ1-3 PE	Shielding layer
GS1		GS1-1 116	Front car door switch connection 1
		GS1-2 117	Front car door switch connection 2
GS2		GS2-1 116F	Rear car door switch connection 1
		GS2-2 117F	Rear car door switch connection 2
GS3		GS3-1 116A	Auxiliary lock switch connection 1 of car door
		GS3-2 117B	Auxiliary lock switch connection 2 of car door
SN1		SN1-1 112	Safety window switch 1 (safety circuit)
		SN1-2 111	Safety window switch 2 (safety circuit)
SN2		SN2-1 112	Emergency stop switch connection 1 in car (safety circuit)
		SN2-2 113	Emergency stop switch connection 2 in car (safety circuit)
SN2 (Above V6.6)		SN2-1 112	Emergency stop switch connection 1 in car (safety circuit)
		SN2-2 112A	Emergency stop switch connection 2 in car (safety circuit)
SN3		SN3-1 110A	Limited switch 1(safety circuit)
		SN3-2 111	Limited switch 2(safety circuit)
SN4		SN4-1 110A	Safety pliers switch connection 1 (safety circuit)
		SN4-3 110	Safety pliers switch connection 2 (safety circuit)
SN5 (Above V6.6)		SN5-1 113	Up Final Limit switch 1(safety circuit)
		SN5-2 112A	Up Final Limit switch 2(safety circuit)
PC11		PC11-3 201	Front door motor controller power supply AC220V-N
		PC11-4 PE	Shielding layer
		PC11-6 200	Front door motor controller power supply AC220V-L
PC21		PC21-3 201	Rear door motor controller power supply AC220V-N
		PC21-4 PE	Shielding layer
		PC21-6 200	Rear door motor controller power supply AC220V-L

Chart 11.6 iBL6-DIO-V6.4 interface descriptions (Cont'd)

Terminal	Port	Signal	Function
PC1		PC1-2 CM1	Front door motor open/close door signal public terminal
		PC1-3 QGM1	Front door is forced closing the door(Output)
		PC1-4 GM1	Front door closing (Output)
		PC1-5 KM1	Front door switch (Output)
		PC1-6 GND	Front door open door to position input signal ground
		PC1-7 GMV1	Front door close door to position signal (input)
		PC1-8 KMV1	Front door open door to position signal (input)
		PC2	
PC2-3 QGM2	Rear door is forced closing the door (Output)		
PC2-4 GM2	Rear door closing (Output)		
PC2-5 KM2	Rear door switch (Output)		
PC2-6 GND	Rear door open door to position input signal ground		
PC2-7 GMV2	Rear door close door to position signal (Input)		
PC2-8 KMV2	Rear door open door to position signal (Input)		
MQ1			
		MQ1-2 GND	DC 0V(Car top board input signal ground)
		MQ1-3 ZPS	Re-leveling up door area input
		MQ1-4 ZPX	Re-leveling down door area input
MQ2		MQ2-1 +24V	DC +24V (Output)
		MQ2-2 GND	DC 0V(Car top board input signal ground)
		MQ2-3 SMQ	Up-leveling input
		MQ2-4 XMQ	Down-leveling input
LW1		LW1-1 +24V	DC +24V (Output)
		LW1-2 GND	DC 0V (Car top board input signal ground)
		LW1-3 CZ	Over load switch input
		LW1-4 MZ	Full load switch input
LW2		LW2-1 +24V	DC +24V (Output)
		LW2-2 GND	DC 0V (Car top board input signal ground)
		LW2-3 BZ	Half load switch,50% load(Input)
		LW2-4 QZ	Light load switch(Input)
OUT1		OUT1-1 BL1	Arrival clock relay output 1
		OUT1-2 GND	DC 0V
		OUT1-3 BL2	Arrival clock relay output 2
		OUT1-4 +24V	DC +24V (Output)
OUT2		OUT2-1 BYO	Bypass alarm output <b>(* Note; relay is connected, output DC +24V)</b>
		OUT2-2 GND	DC 0V
		OUT2-3 Spare	Spare
		OUT2-4 Spare	Spare

Chart 11.6 iBL6-DIO-V6.4 interface description (Cont'd)

Terminal	Port	Signal	Function
IPS		IPS-1 GND	Emergency power supply(DC 0V)
		IPS-2 YJD	Emergency light power supply input(DC 12V)
		IPS-4 N1	AC220V-N(*Output,Emergency power recharge)
		IPS-5 B3	Emergency alarm bell input (*connect ground bell)
		IPS-6 DC12	Emergency power supply input(DC12V)
		IPS-8 L31	AC220V-L (* Output,Emergency power recharge)
ICU6		ICU6-1 GND	Car top five party intercom power supply DC0V(output)
		ICU6-2 #2	Car top five party intercom#2
		ICU6-5 #1	Car top five party intercom#1
		ICU6-6 DC12	Car top five party intercom DC12V(output)
DJX		DJX-1 MS1	Car top inspection up input
		DJX-2 MX1	Car top inspection down input
		DJX-3 130	Car top inspection switch input (parallel)
		DJX-4 DJX	Car top inspection switch input (serial)
		DJX-5 GND	Input signal ground(DC 0V)
		DJX-6 190	Car top inspection switch (safety circuit)
		DJX-7 111	Car top inspection switch (safety circuit)
		DJX-8 116	Car top Emergency stop switch (safety circuit)
		DJX-9 113	Car top emergency stop switch (safety circuit)
DJX (Above V6.6)		DJX-1 MS1	Car top inspection up input
		DJX-2 MX1	Car top inspection down input
		DJX-3 130	Car top inspection switch input (parallel)
		DJX-4 DJX	Car top inspection switch input (serial)
		DJX-5 GND	Input signal ground(DC 0V)
		DJX-7 190	Car top inspection switch (safety circuit)
		DJX-8 111	Car top inspection switch (safety circuit)
		DJX-9 116	Car top Emergency stop switch (safety circuit)
		DJX-10 113	Car top emergency stop switch (safety circuit)
		DJX-11 110	Car top INS. Bridging emergency electric and bypass switches (safety circuit)
		DJX-12 109A	Car top INS. Bridging emergency electric and bypass switches (safety circuit)
		SPC (Above V6.6)	
SPC-2 118	Safety circuit (SPC short circuit door lock circuit)		
SPC-3 116	Safety circuit (SPC short circuit door lock circuit)		
SPC-6 DC12	DC 12V(Output)		
SPC-7 +24V	DC +24V (Output)		
SPC-8 C+	Car CAN COM CAN-H(SPC)		
SPC-9 111	Safety circuit(SPC Cut off the safety circuit)		
SPC-10 116F	Safety circuit (SPC short circuit door lock circuit)		
SPC-14 ZPS	UP Door area signal of EPD for MRL		
SPC-15 GND	DC 0V (Output)		
SPC-16 C-	Car CAN COM CAN-L(SPC)		

Chart 11.6 iBL6-DIO-V6.4 interface description (Cont'd)

Terminal	Port	Signal	Function		
DC3		DC3-1 200-1	Door motor power supply input AC 220V-L		
		DC3-3 PE	Shielding layer		
		DC3-4 116	Safety circuit (car top emergency stops, car door lock circuit starting point)		
		DC3-5 117	Front hall/car door sealed test point		
		DC3-6 117F	Rear hall/car door sealed test point		
		DC3-8 N1	Car top lighting power input(AC 220V-N)		
		DC3-9 201	Door motor power supply input AC 220V-N		
		DC3-11 118	The middle point of the front side door and the rear side door.		
		DC3-12 190	Safety circuit (car top inspection prohibits emergency electric operation)		
		DC3-13 110	Safety circuit (Safety pliers)		
		DC3-14 116F	Safety circuit (return point of car door lock circuit)		
		DC3-16 L31-1	Car top lighting power input(AC 220V-L)		
		DC3 (Above V6.6)		DC3-1 200-1	Door motor power supply input AC 220V-L
				DC3-3 PE	Shielding layer
				DC3-4 116	Safety circuit (car top emergency stops, car door lock circuit starting point)
				DC3-5 117	Front hall/car door sealed test point
DC3-6 117F	Rear hall/car door sealed test point				
DC3-9 N1	Car top lighting power input(AC 220V-N)				
DC3-10 201	Door motor power supply input AC 220V-N				
DC3-12 118	The middle point of the front side door and the rear side door.				
DC3-13 190	Safety circuit (car top inspection prohibits emergency electric operation)				
DC3-14 110	Safety circuit (Safety pliers)				
DC3-15 116F	Safety circuit (return point of car door lock circuit)				
DC3-16 109A	Car top INS. Bridging emergency electric and bypass switches (safety circuit)				
DC3-18 L31-1	Car top lighting power input(AC 220V-L)				
DC2				DC2-1 117B	Car door auxiliary lock switch+
				DC2-2 116A	Car door auxiliary lock switch-
				DC2-3 +24V	DC +24V input(Car top power supply)
		DC2-4 GND	DC 0V input(Car top power supply \ Intercom power common ground)		
		DC2-5 C+	CAN COM CANH		
		DC2-6 C-	CAN COM CANL		
		DC2-7 ZPS	Up door area re-leveling input signal		
		DC2-9 130	Car top inspection switch wiring		
		DC2-10 ZPX	Down door area re-leveling input signal		
		DC2-11 DC12	Five party intercom power supply DC +12Voutput(Return machine room)		
		DC2-12 #2	Car top five party intercom #2		
		DC2-13 #1	Car top five party intercom #1		
		DC2-14 GND3	Power ground of inorganic room		

Chart 11.6 iBL6-DIO-V6.4 interface description (Cont'd)

Terminal	Port	Signal	Function		
DC4 (V6.5)		DC4-1 SDZ1	Up slow down 1		
		DC4-2 SDZ2	Up slow down 2		
		DC4-3 XDZ1	Down slow down 1		
		DC4-4 XDZ2	Down slow down 2		
DHC3 (Above V6.6)		DHC3-1 Spare	Spare		
		DHC3-2 Spare	Spare		
		DHC3-3 SDZ1	Up slow down 1		
		DHC3-4 SDZ2	Up slow down 2		
DHC4 (Above V6.6)		DHC4-1 Spare	Spare		
		DHC4-2 Spare	Spare		
		DHC4-3 XDZ1	Down slow down 1		
		DHC4-4 XDZ2	Down slow down 2		
DZ		DZ-1 +24V	DC +24V (Output)		
		DZ-2 SDZ1	Up slow down 1		
		DZ-3 SDZ2	Up slow down 2		
		DZ-4 GND	DC 0V (Car top board input signal ground)		
		DZ-5 XDZ1	Down slow down 1		
		DZ-6 XDZ2	Down slow down 2		
KAB1		KAB1-1 201	AC220V-N(Note; output, power supply to the front door light screen)		
		KAB1-3 PE	Shielding layer		
		KAB1-4 GND	DC 0V(Car top board input signal ground)		
		KAB1-5 +24V	DC +24V (Output)		
		KAB1-6 GND	DC 0V(Car top board input signal ground)		
		KAB1-7 200	AC220V-L(Note; output, power supply to the front door light screen)		
		KAB1-9 PE	Shielding layer		
		KAB1-10 KAB1	Front door safe touch panel signal input		
		KAB1-11 GND	DC 0V(Car top board input signal ground)		
		KAB1-12 LSB1	Front door light screen signal input		
		KAB2		KAB2-1 201	AC220V-N(Note; output, power supply to the rear door light screen)
				KAB2-3 PE	Shielding layer
KAB2-4 GND	DC 0V(Car top board input signal ground)				
KAB2-5 +24V	DC +24V(Output)				
KAB2-6 GND	DC 0V(Car top board input signal ground)				
KAB2-7 200	AC220V-L(Note; output, power supply to the rear door light screen)				
KAB2-9 PE	Shielding layer				
KAB2-10 KAB2	Rear door safe touch panel signal input				
KAB2-11 GND	DC 0V(Car top board input signal ground)				
KAB2-12 LSB2	Rear door light screen signal input				

Chart 11.6 iBL6-DIO-V6.4 interface description (Cont'd)



Terminal	Port	Signal	Function		
DC9-1		DC9-1-4 B3	Emergency alarm bell output ( <b>*connect ground bell</b> )		
		DC9-1-5 +24V	DC +24V output(for car inside use)		
		DC9-1-6 +24V	DC +24V output(for car inside use)		
		DC9-1-7 C+	CAN COM CAN-H		
		DC9-1-8 GND	Power ground (Emergency power DC 0V,common ground with DC24V)		
		DC9-1-9 GND	Power ground (Emergency power DC 0V,common ground with DC24V)		
		DC9-1-10 YJD	Emergency light power output (DC 12V)		
		DC9-1-11 DC12	emergency power output(DC12V)		
		DC9-1-12 #2	Car top five party intercom #2		
		DC9-1-13 #1	Car top five party intercom #1		
		DC9-1-14 C-	CAN COM CAN-L		
		DC9-2		DC9-2-4 B3	Emergency alarm bell output ( <b>*connect ground bell, for rear door</b> )
				DC9-2-5 +24V	DC +24V output(for car inside use)
				DC9-2-6 +24V	DC +24V output(for car inside use)
DC9-2-7 C+	CAN COM CAN-H(Auxiliary COP)				
DC9-2-8 GND	Power ground (Emergency power DC 0V,common ground with DC24V)				
DC9-2-9 GND	Power ground (Emergency power DC 0V,common ground with DC24V)				
DC9-2-10 YJD	Emergency light power output (DC 12V, for rear door)				
DC9-2-11 DC12	emergency power output(DC12V)				
DC9-2-12 #2	Car top five party intercom #2(for rear door)				
DC9-2-13 #1	Car top five party intercom #1(for rear door)				
DC9-2-14 C-	CAN COM CAN-L(Auxiliary COP)				
WMQ				WMQ-1 +24V	DC +24V output
				WMQ-2 GND3	DC +24V output
				WMQ-3 ZPS	Power ground of inorganic room
		WMQ-4 ZPX	Up-leveling signal of inorganic room electric sluice		
CN1		CN1-1~40 2.54*40P	Connect to car top board BL2000-JDB-V6.X		

Chart 11.7 Car Top Interface Board iBL6-DIO-V6.x indicator description

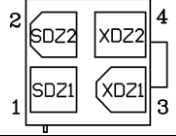
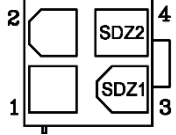
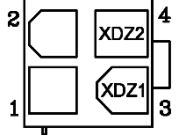
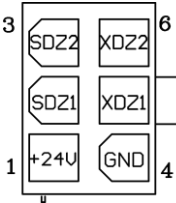
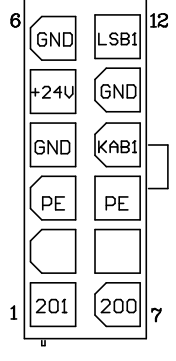
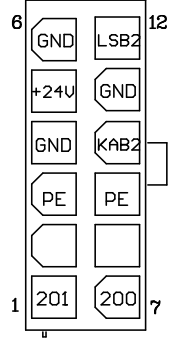
Indicator	Function
Y0	Arrival clock output (on; with arrival clock output/off; without arrival clock output)
Y1	Turn off lighting output (on; with turn off lighting output/off; without turn off lighting output)
Y2	Bypass alarm output (on; with bypass alarm output/off; without bypass alarm output)
Y3	Turn off fan output (on; with turn off fan output/off; without turn off fan output)

## 11.3. POBK Serial Brake Power Board

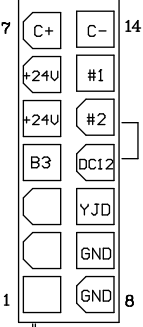
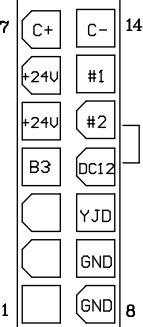
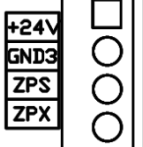
### 11.3.1 POBK-V1.2 Brake Power Board

POBK-V1.2 brake power board supplies DC110V brake power to cabinet interface board and DC24V as signal power.



Figure 11.5 POBK-V1.2 Brake power board

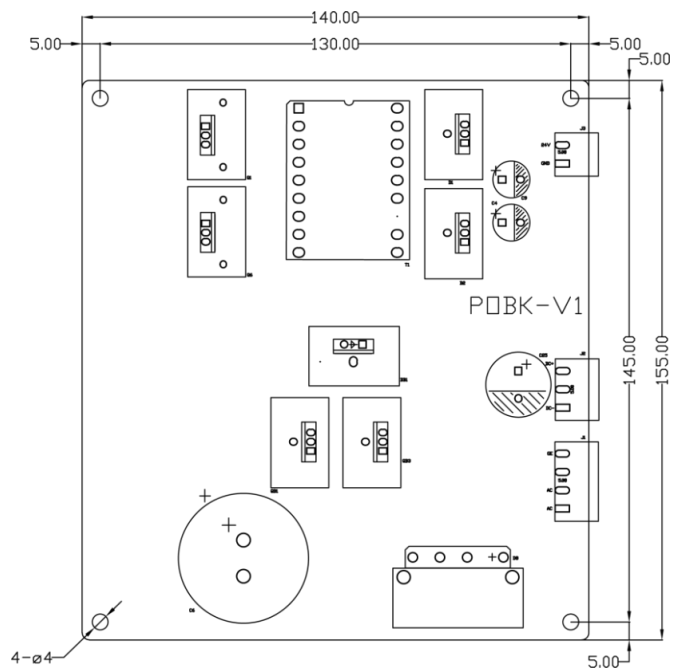

Figure 11.6 POBK-V1.2 Brake power board component location and dimension

11.3.2 SJT-POBK-V1.3 Brake Power Board (New standard)



Figure 11.7 SJT-POBK-V1.3 Brake Power Board

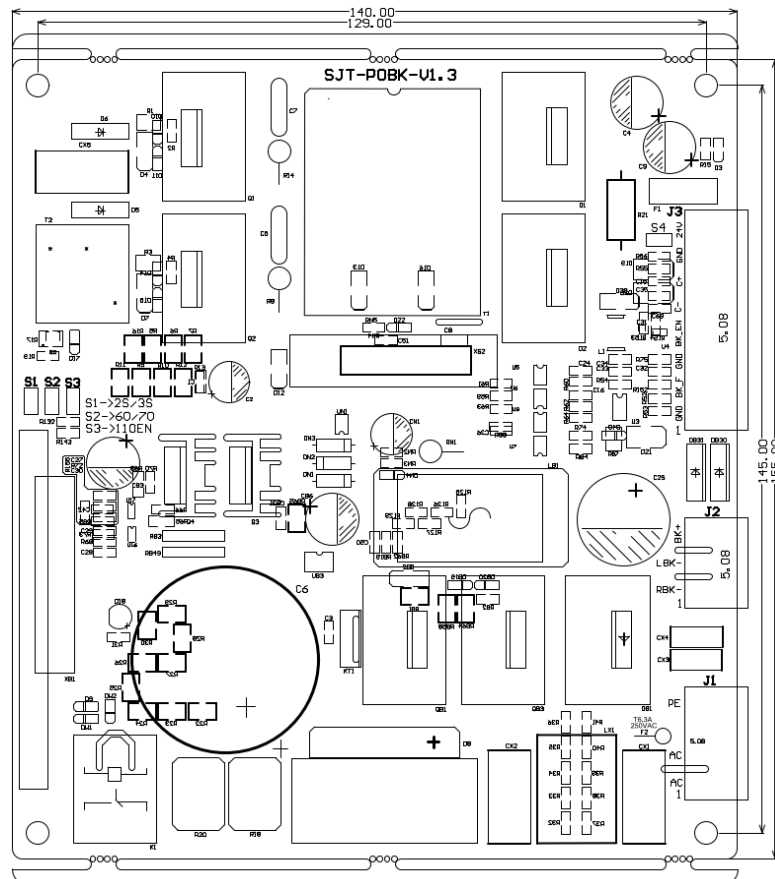

Figure 11.8 SJT-POBK-V1.3 Dimension

**Function specification**

1. Dual brake power output and individual control to perform single brake open function.
2. Dual control of brake power output, only output brake power when CAN Bus and brake enable output both valid, which supply brake control safety.
3. Brake output fault feedback. When brake voltage output short circuit, overcurrent or other fault, it can feedback to mainboard through CAN Bus and hardware signal at same time.
4. It can achieve half voltage holding function of brake power. The holding voltage default is 75VDC. Besides, it can choose 75VDC or 65VDC holding voltage through jumper (refers to chart 11.9) and cancel half voltage holding function (With this function, the maximum output capacity can be 260w (110V, 2.36A).
5. The maximum brake open capacity of brake power is 550W (output 5A), output capacity at steady state is 260W (75VDC,3.5A)
6. 24VDC power output, maximum output current is 5A.

**Chart 11.8 the brake & power supply board interface description**

Terminal	Port	Signal	Function
J1	<div style="border: 1px solid black; padding: 2px; display: inline-block;">                     4 PE                      3 /                      2 AC                      1 AC                 </div>	J1-PE	Shielding layer
		Spare	Spare
		J1-AC	AC 220V Input
		J1-AC	
J2	<div style="border: 1px solid black; padding: 2px; display: inline-block;">                     3 BK+                      2 LBK-                      1 RBK-                 </div>	J2-BK+	DC 110V Output
		J2-LBK-	Spare
		J2-RBK-	DC 0V Output
J3	<div style="border: 1px solid black; padding: 2px; display: inline-block;">                     8 +24V                      7 GND                      6 C+                      5 C-                      4 BK-EN                      3 GND                      2 BK-F                      1 GND                 </div>	J3-24V	DC 24V Output Max output current 5A
		J3-GND	
		J3-C+	CAN bus communication
		J3-C-	
		J3-BK_EN	The output enable control terminal of the brake power supply is controlled by the normally open point of the KLZ contactor
		J3-GND	
		J3-BF_F	Brake power supply fault feedback output terminal (optocoupler OC output)
		J3-GND	

**Chart 11.9 Half voltage holding setting**

Jumper	Full voltage open time (Open voltage is DC 110V)	Half voltage holding voltage
No jumper (Default)	3.2 sec	DC 75V
S1	2.2 sec	DC 75V
S2	3.2 sec	DC 65V
S3	Disable half voltage holding (Keep full voltage open brake) (Maximum output capacity is 260W)	

11.3.2 Wiring Diagram (Take SJT-POBK-V1.3 for example)

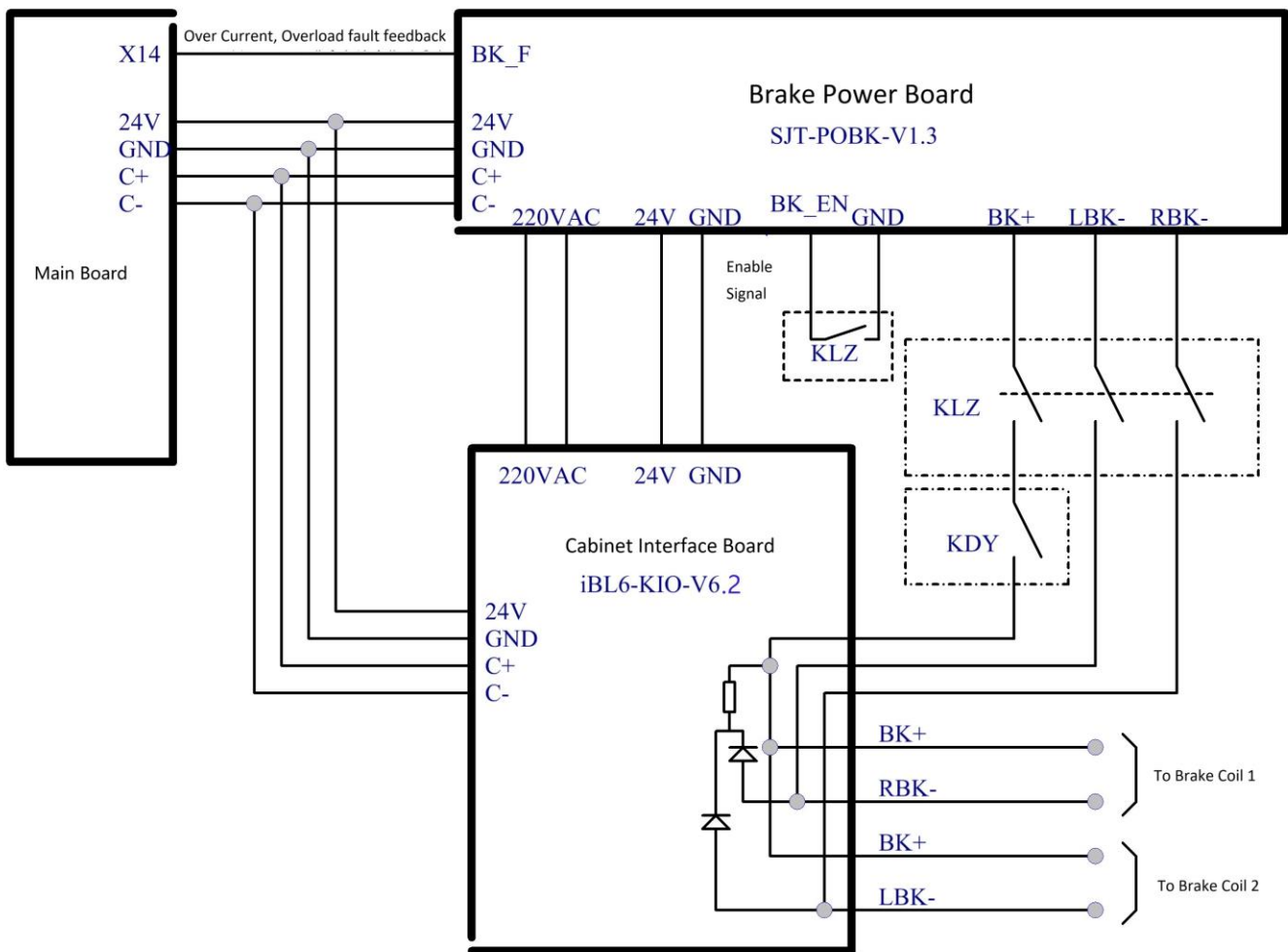

Figure 11.9 System connection diagram

## 11.4. SJT-OVP-V2A Overvoltage Protection Board

The overvoltage protection board provides power for the brake power supply board and the door motor. When the AC220 input voltage is less than AC280V, the overvoltage protection board does not work, the AC power is normally output to J1, J2, when the input voltage is higher than AC280V, the overvoltage protection board works, disconnect output, then J1, J2 has no voltage output at this time.

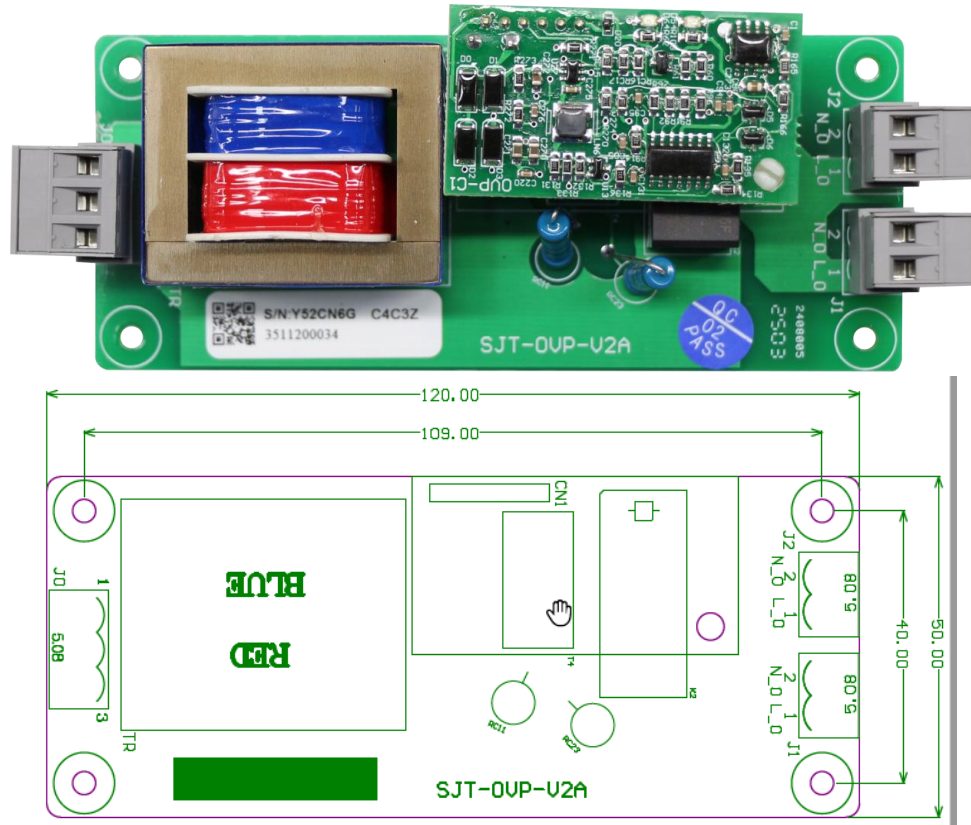

FIGURE 11.10 SJT-OVP-V2A Overvoltage protection board physical image and component location and size diagram

Chart 11.10 Overvoltage protection board interface description

Terminal	Port	Signal	Function						
J0	<table border="1"> <tr><td>1</td><td>V0</td></tr> <tr><td>2</td><td>\</td></tr> <tr><td>3</td><td>N</td></tr> </table>	1	V0	2	\	3	N	J0_1	AC 220V Input
		1	V0						
		2	\						
3	N								
J0_2	Spare								
J0_3	AC 220V Input								
J1	<table border="1"> <tr><td>1</td><td>200</td></tr> <tr><td>2</td><td>201</td></tr> </table>	1	200	2	201	J1_1	Door motor power(AC220V-L)		
		1	200						
2	201								
J1_2	Door motor power (AC220V-N)								
J2	<table border="1"> <tr><td>1</td><td>200</td></tr> <tr><td>2</td><td>201</td></tr> </table>	1	200	2	201	J2_1	Brake power(AC220V-L)		
		1	200						
2	201								
J2_2	Brake power (AC220V-N)								

### 11.5. BL2000-JDB-V6.4 Car Top Board

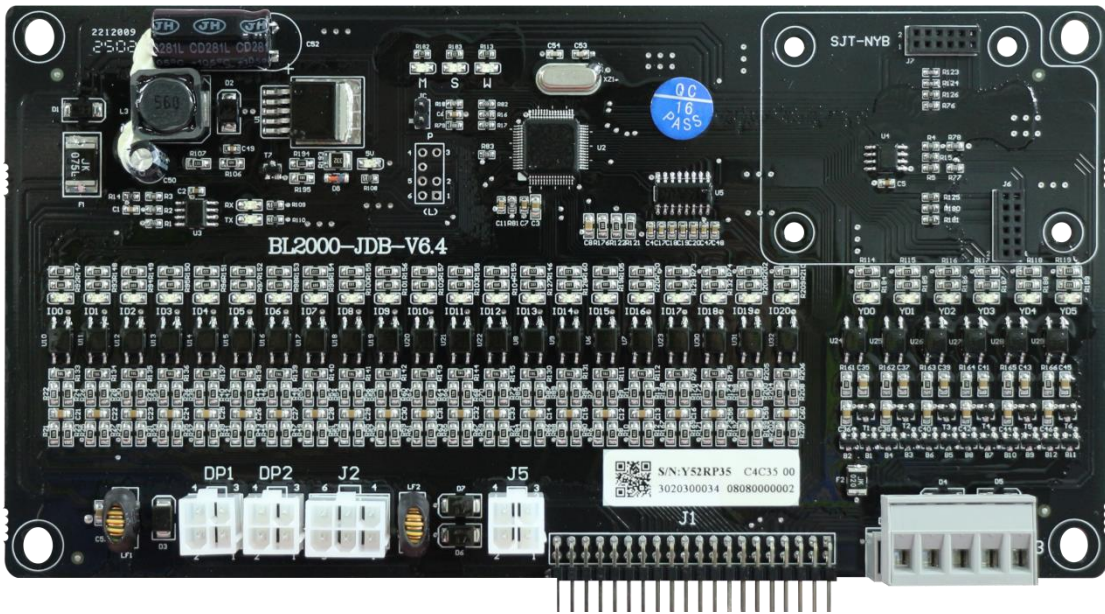

FIGURE 11.11 BL2000-JDB-V6.4 car top board physical map

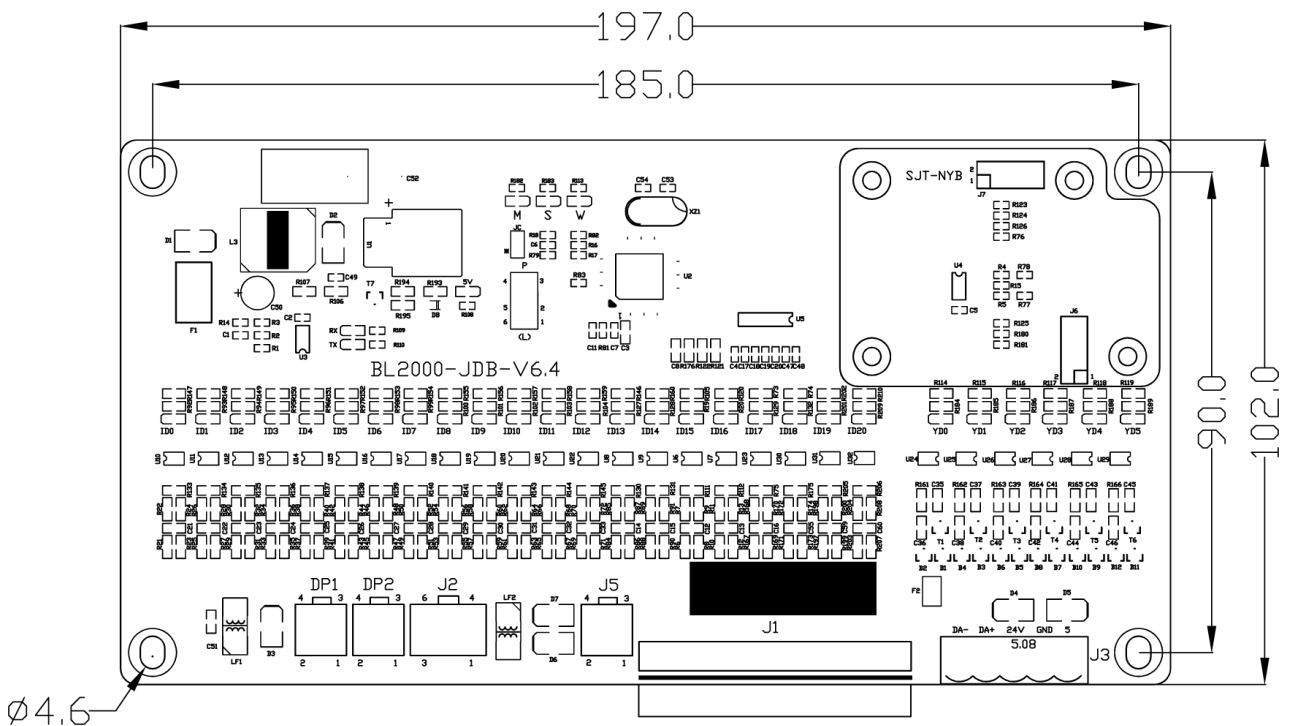

FIGURE 11.12 BL2000-JDB-V6.4 device position and size diagram of the car top board

Chart 11.11 Car top board interface descriptions

Terminal	Port	Signal	Function
J1	 <p>2.54 interval 2*20 pins</p>	J1-1	J1-2~J1-7 Output public terminal
		J1-2	Force door closing output 2
		J1-3	door closing output 2
		J1-4	door opening output 2
		J1-5	Force door closing output 1
		J1-6	door closing output 1
		J1-7	door opening output 1
		J1-8	Arrival clock output
		J1-9	Fan output
		J1-10	Lighting output
		J1-11	Bypass alarm output
		J1-12	Down-leveling input
		J1-13	Down running input
		J1-14	Up-leveling input
		J1-15	Inspection input
		J1-16	Up running input
		J1-17	Full load input
		J1-18	Over load input
		J1-19	Light load input
		J1-20	Half load input
		J1-21	Safety Plate 2 Input
		J1-22	Light screen 2 Input
		J1-23	door open limit 2 input
		J1-24	door close limit 2 input
		J1-25	Safety Plate 1 Input
		J1-26	Light screen 1 Input
		J1-27	door open limit 1 input
		J1-28	door close limit 1 input
		J1-29	CAN Bus L
		J1-30	
		J1-31	CAN Bus H
		J1-32	
		J1-33	24V Input ground
		J1-34	
		J1-35	
		J1-37	24V Input
		J1-38	
		J1-39	
		J1-40	

Chart 11.11 Car top board interface description (Cont'd)



Terminal	Port	Signal	Function
J3		J3-1	RS485 COM RT-
		J3-2	RS485 COM RT+
		J3-3	24V
		J3-4	GND
DP1		DP1-1	24V
		DP1-2	GND
		DP1-3	Front door machine overheat protection input
		DP1-4	Spare
DP2		DP2-1	24V
		DP2-2	GND
		DP2-3	Rear door machine overheat protection input
		DP2-4	Spare
J2		J2-1	Spare input 0
		J2-2	Spare input 1
		J2-3	Spare 24V output
		J2-4	Spare input 1(OC output)
		J2-5	Spare input 2(OC output)
		J2-6	Spare output common port
J5		J5-1	Spare 24V input
		J5-2	Spare 24V input ground
		J5-3	Spare CAN Bus H
		J5-4	Spare CAN Bus L
USB1 (SJT-NYB)		USB1	Arrival gong / voice announcer module USB port
LS (SJT-NYB)		LS	Arrival gong / voice announcer module Sound box interface

Chart 11.12 Car Top Board indicator description

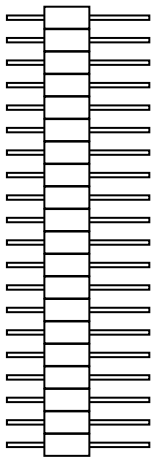
Indicator	Function
W	Car top board working indicator
5V	Power indicator
RX	CAN Receive indicator
TX	CAN Send indicator
M	Communication indicator light with the main <b>car Instruction</b> board (on; communication; off; no communication)
S	Communication indicator light with the secondary <b>car Instruction</b> board (on; communication; off; no communication)
ID0	Open door limit 1 input (on; input point is conductive; off; input point is not conductive)
ID1	Door closing limit 1 input (on; input point is conductive; off; input point is not conductive)
ID2	Safety touch panel 1 input (on; input point is conductive; off; input point is not conductive)
ID3	Light curtain 1 input (on; input point is conductive; off; input point is not conductive)
ID4	Open door limit 2 input (on; input point is conductive; off; input point is not conductive)
ID5	Door closing limit 2 input (on; input point is conductive; off; input point is not conductive)
ID6	Safety touchpad 2 input (on; input point is conductive; off; input point is not conductive)
ID7	Light curtain 2 input (on; input point is conductive; off; input point is not conductive)
ID8	Light load input (on; input point is conductive; off; input point is not conductive)
ID9	Half load input (on; input point is conductive; off; input point is not conductive)
ID10	Full load input (on; input point is conductive; off; input point is not conductive)
ID11	Overload input (on; input point is conductive; off; input point is not conductive)
ID12	INS. input (on; input point is conductive; off; input point is not conductive)
ID13	INS. Up input (on; input point is conductive; off; input point is not conductive)
ID14	INS. Down input (on; input point is conductive; off; input point is not conductive)
ID15	Upper door area input (on; input point is conductive; off; input point is not conductive)
ID16	Under door area input (on; input point is conductive; off; input point is not conductive)
ID17	Car top spare input 0 (on; input point is conductive; off; input point is not conductive)
ID18	Car top spare input 1 (on; input point is conductive; off; input point is not conductive)
ID19	Front door machine overheat protection input (on; input point is conductive; off; input point is not conductive)
ID20	Rear door machine overheat protection input (on; input point is conductive; off; input point is not conductive)
YD0	Open door 1 output (on; output; off; no output)
YD1	Close door 1 output (on; output; off; no output)
YD2	Forced close door 1 output (on; output; off; no output)
YD3	Open door 2 output (on; output; off; no output)
YD4	Close door 2 output (on; output; off; no output)
YD5	Forced close door 2 output (on; output; off; no output)

## 11.6. BL2000-ZLB-V6.x Car Instruction Board

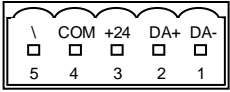
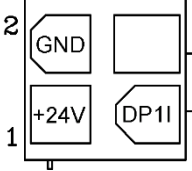
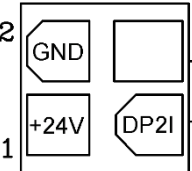
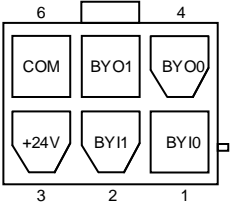
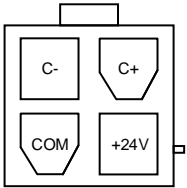
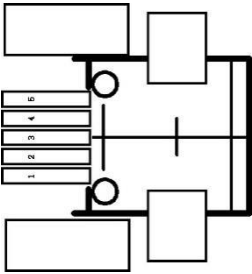
BL2000-ZLB-V6.x has 16 levels internal selection buttons and response interfaces. By connecting the car expansion board BL2000-CEB-V6.1 (each panel has 8 inner selection buttons and response interface), or BL2000-CEB-V7.1(each panel has 16 inner selection buttons and response interface),it can be extended to 64 levels of control. Supports voice announcement and IC card functions. Please refer to the product manual for detailed information.

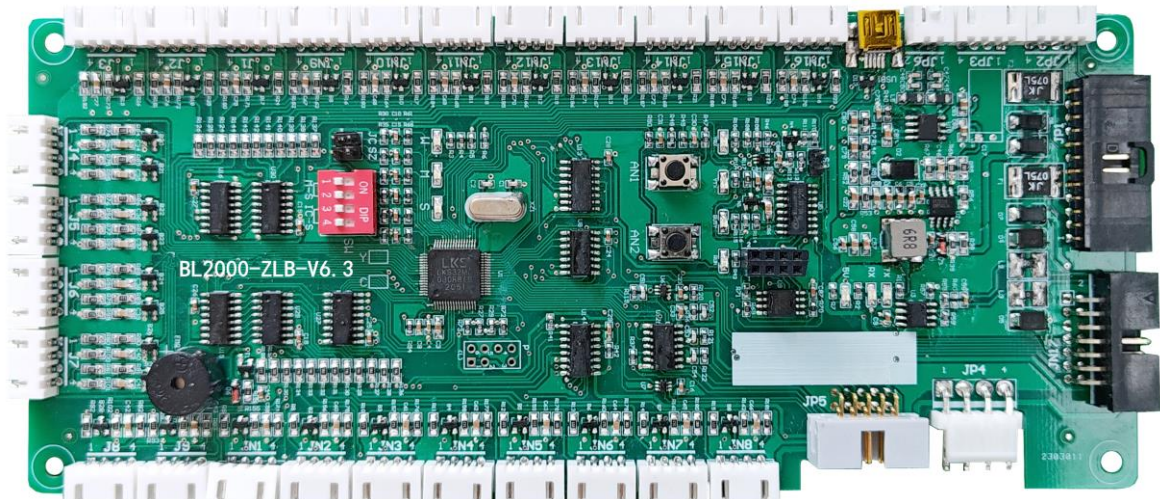

FIGURE 11.13 BL2000-ZLB-V6.x Car Instruction Board physical map

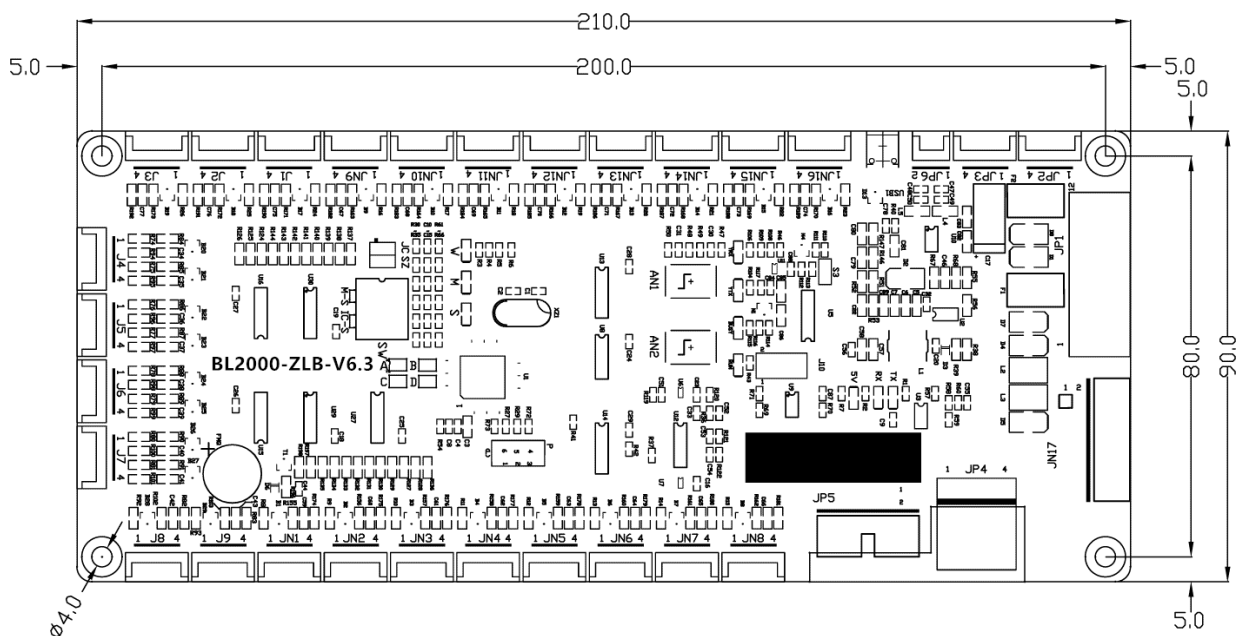

FIGURE 11.14 BL2000-ZLB-V6.x Device position and size diagram of Car Instruction Board

Chart 11.13 Car Instruction Board interface description



Terminal	Port	Signal	Function
JN1-JN16		JNn-1	Response output
		JNn-2	24V
		JNn-3	24V
		JNn-4	Input
JN17		14Pin curved	Internal selection extension cascade
J1		J1-1	Door open button response
		J1-2	24V
		J1-3	24V
		J1-4	Door open button input
J2		J2-1	Door close button response
		J2-2	24V
		J2-3	24V
		J2-4	Door close button input
J3		J3-1	Door open delay button response
		J3-2	24V
		J3-3	24V
		J3-4	Door open delay button input
J4		J4-1	Input common port
		J4-2	Attendant Up
		J4-3	Input common port
		J4-4	Attendant Down
J5		J5-1	Input common port
		J5-2	Attendant Input
		J5-3	Input common port
		J5-4	Special input
J6		J6-1	Input common port
		J6-2	Drive by-pass Input
		J6-3	Input common port
		J6-4	Fireman input
J7		J7-1	Input common port
		J7-2	Fan switch input
		J7-3	Input common port
		J7-4	Lighting switch input
J8		J8-1	Input common port
		J8-2	Spare input 0
		J8-3	Input common port
		J8-4	Spare input 1
J9		J9-1	Power 24V
		J9-2	Spare output 0
		J9-3	0V
		J9-4	Spare output 1

Chart 11.13 Car Instruction Board interface description (Cont'd)

Terminal	Port	Signal	Function		
JP1		JP1-1	Alarm button input power		
		JP1-2	24V Power input		
		JP1-3	24V Power input		
		JP1-4	CAN Bus H		
		JP1-5	Power 0V		
		JP1-6	Power 0V		
		JP1-7	Emergency light output		
		JP1-8	Intercom power 12V		
		JP1-9	Intercom communication line		
		JP1-10	Intercom communication line		
		JP1-11	CAN Bus L		
JP2		JP2-1	Intercom power 12V, 12V Power		
		JP2-2	Power 0V		
		JP2-3	Intercom communication line		
		JP2-4	Intercom communication line		
JP3		JP3-1	Emergency light output +		
		JP3-2	Emergency light output -		
		JP3-3	Power 0V		
		JP3-4	Alarm button input		
JP4		JP4-1	+24V Power		
		JP4-2	Power 0V		
		JP4-3	CAN Bus H		
		JP4-4	CAN Bus L		
JP5		10Pin curved	IC card communication port		
JP6		2P socket	Speaker interface		
USB1		MINI USB	Voice announcement file update USB interface		
AN1/AN2		Button	Voice announcement setting button		
JC		2.54 spacing jumper	Detection setting jumper		
SZ			Setting jumper		
SW		SW1 SW2	Program Function	SW3	SW4
		OFF OFF	main Instruction board	ON: IC card enabled	ON: Connect to other IC card systems
		OFF ON	Single instruction board through door		
		ON OFF	Secondary instruction board	OFF: IC card disabled	OFF: Connect to the blue light IC card module
ON ON	Secondary instruction board through door				

Chart 11.14 Car instruction board indicator Instruction

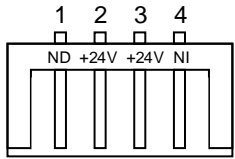
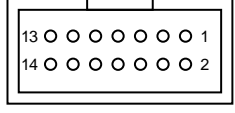
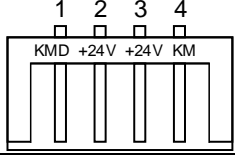
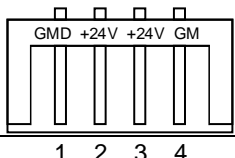
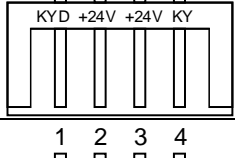
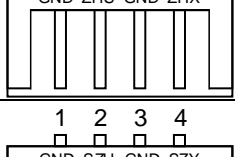
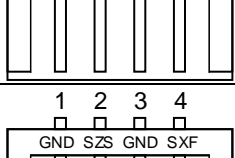
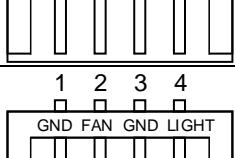
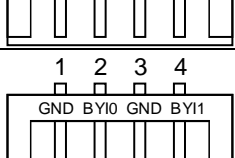
Indicator	Function	Indicator	Function
W	Instruction board working indicator	5V	Power indicator
M	Main instruction board mode	YRX	Voice announcement communication indicator
S	Secondary instruction board mode	YTX	Voice announcement communication indicator
RX	CAN Receive indicator	BUSY	Voice announcement busy indicator
TX	CAN Send indicator	RUN	Voice announcement running indicator

## Appendix 1 Hoistway Switches Information (Partly)

### F1.1 Leveling Switches & Flag Installation

For elevator leveling control, two leveling switches (up/down leveling switches) and some door zone flags (one in each floor) are required. Two leveling switches are installed on top of car, door zone flag is installed in hoistway, their dimensions and positions are illustrated in Figure F1.1. Leveling switches can be optical or magnetic.

Door zone flag adjustment;

1. Elevator stop at each floor, measure car and hall sills difference  $\Delta S$  on each level at elevator park (car sills higher is position, lower is negative)
2. Adjust door zone flag on each floor, if  $\Delta S > 0$ , flag on this floor should move down  $\Delta S$ ; move flag up  $\Delta S$  if  $\Delta S < 0$ .
3. Elevator need to redo the hoistway parameter learning after door zone flag adjustment.
4. Check elevator leveling on each floor, read part 1-3 if necessary.

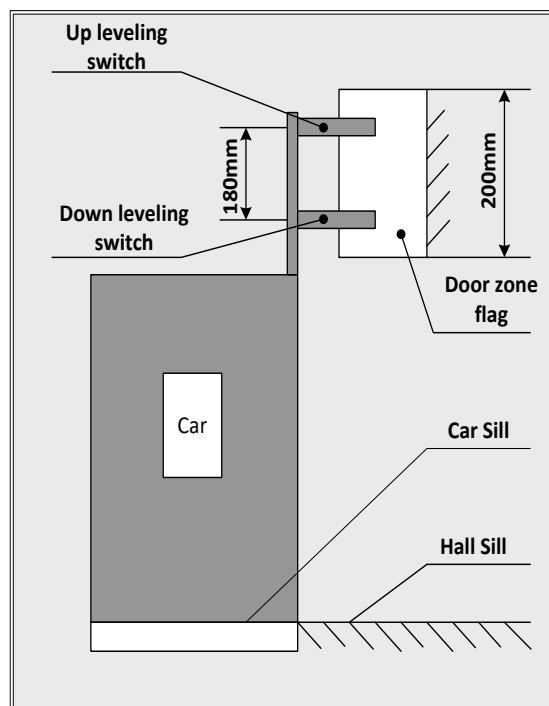
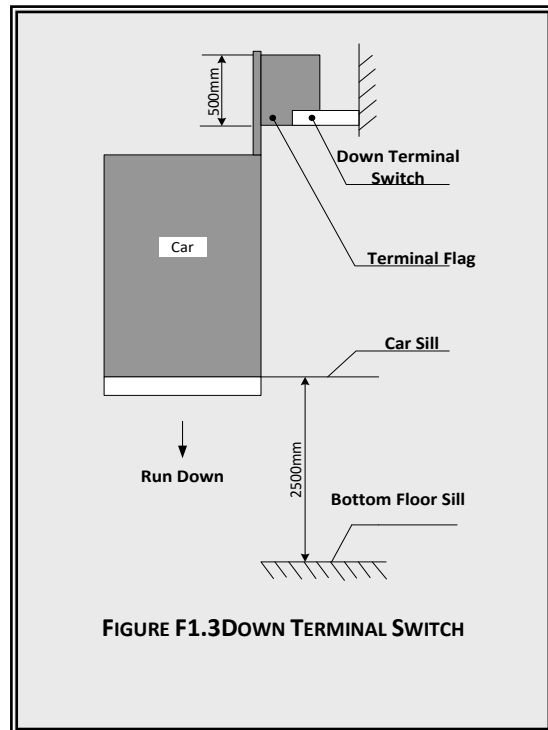
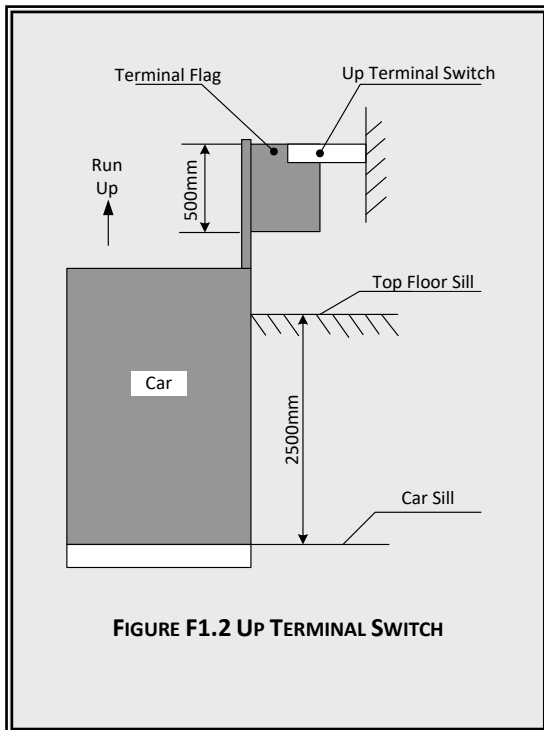

FIGURE F1.1 DOOR ZONE FLAG & LEVELING SWITCH POSITION

### F1.2 Up/Down Terminal Switches Installation

1. Terminal switches are recommended to use non-contact type, such as magnetic switch.
2. Up/Down terminal switches are installed in hoistway guide rail; terminal flag is installed on top of car. Their positions are shown below in Figure F1.2 & F1.3.

3. For elevator speed  $\leq 1.75\text{m/s}$ , only one up and one down terminal switch and one terminal flag is required. For elevator speed  $\geq 2.0\text{m/s}$ , more terminal switches should be installed for safety purpose. Please see below Chart F1.1 for up/down terminal switches position with different elevator speed.



**Chart F1.1 Up/Down Terminal Switches with different elevator speed**

Terminal \ Speed	Terminal Switch Location		
	0.5m/s	1.0m/s	1.6m/s 1.75m/s
Up/Down Terminal Switch 1	1m	1.3m	2.5m

### F1.3 Confirm the Terminal Switches Location

Up/down terminal switches signal is used for elevator force change speed and floor position calibration, they should be installed 2.5m from car top/bottom to top/bottom floor leveling position. (For elevator speed at 1.6m/s or 1.75m/s). To confirm such position;

1. Make sure elevator in inspection mode;
2. Set inspection speed to 0.3m/s , run up/down elevator;
3. Stop elevator when touching up/down terminal switches;
4. At this time the car sills and hall sills should have a distance of  $2.5 \pm 0.1\text{m}$ .

## Appendix 2 Re-Leveling & Door Open in Advance

### F2.1 Safety Control Board (SJT-ZPC-V2A) Drawings

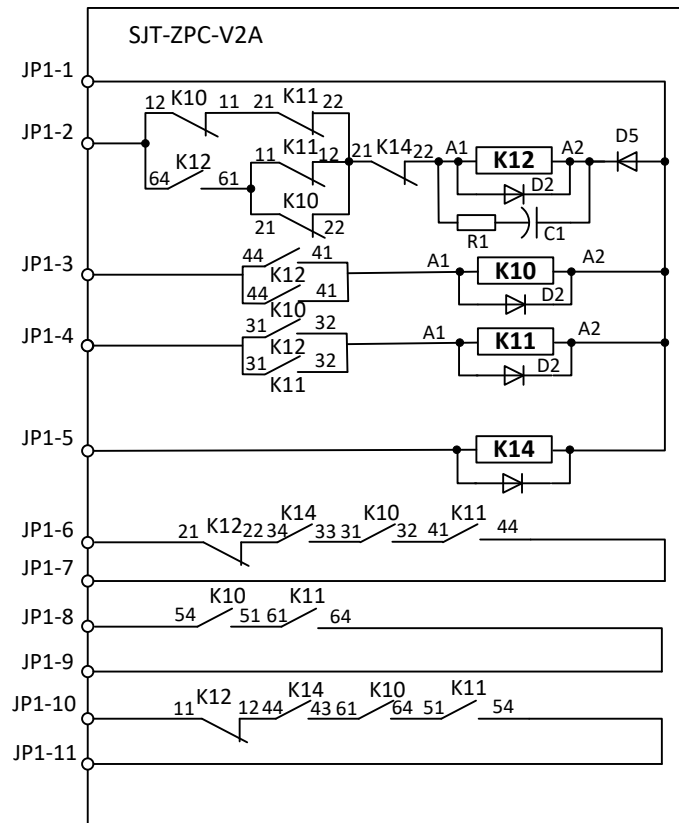

Figure F2.1 Safety Control Board (SJT-ZPC-V2A) Drawings

### F2.2 Safety Control Board Terminal Definition

Chart F2.1 Safety Control Board Terminal Definition

Name	Location	Definition
JP1	JP1-1	24V+
	JP1-2	0V
	JP1-3	Re-leveling up door zone
	JP1-4	Re-leveling down door zone
	JP1-5	Control system re-leveling conditions satisfied
	JP1-6	Re-leveling conditions satisfied output
	JP1-7	Re-leveling conditions satisfied output Public terminal
	JP1-8	Re-leveling door zone output
	JP1-9	Re-leveling door zone output public terminal
	JP1-10	By-pass door inter-lock +
	JP1-11	By-pass door inter-lock-

### F2.3 Re-Leveling & Door Open in Advance Wiring Diagram

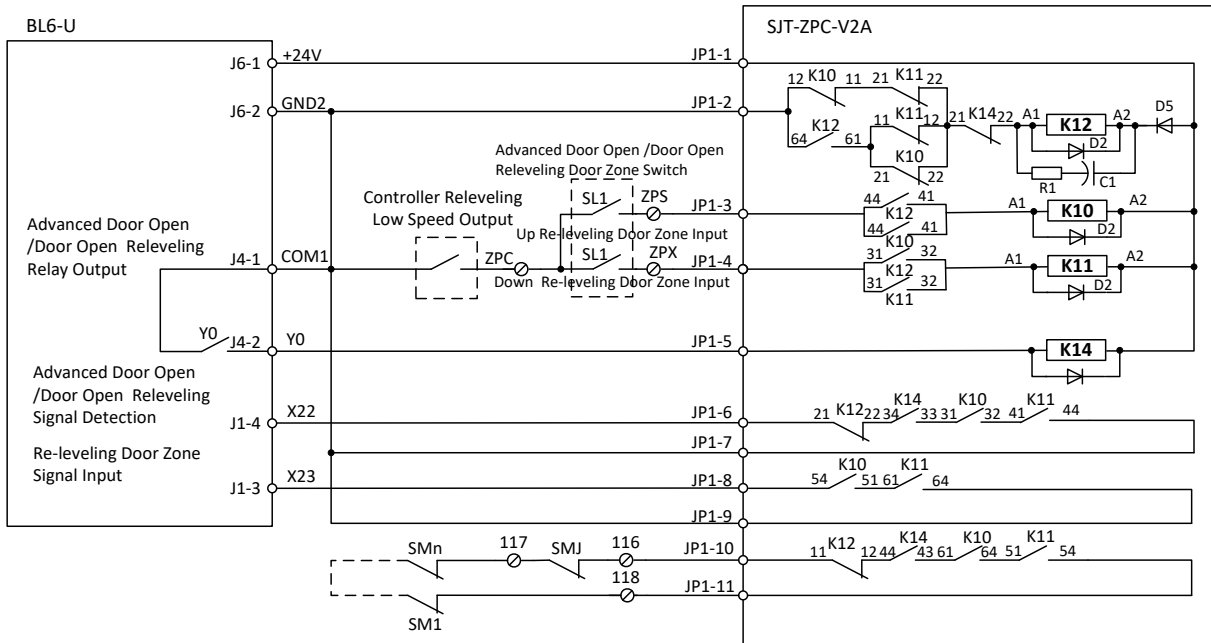

Figure F2.2 Re-Leveling & Door Open in Advance Wiring Diagram

### F2.4 Installation for Re-Leveling Door Zone Switches

When using the function of advance door open and re-leveling, besides the up and down leveling switches, two extra re-leveling switches should also be installed. Their installation is shown in Figure F2.3.

mq1:Up leveling switch; mq2; down leveling switch; sl1; up re-leveling switch; sl2; down re-leveling switch; all leveling switches should be installed in sequence. Otherwise the direction of the re-leveling running will be reversed.

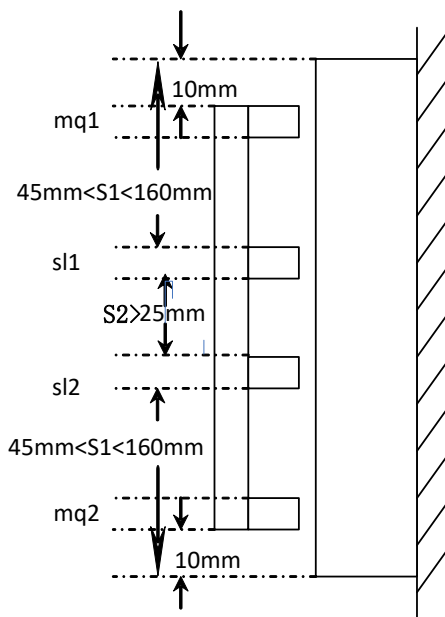

FIGURE F2.3 RE-LEVELING DOOR ZONE SWITCHES POSITION



If SI1 and SI2 are magnetic sensor, their distance must remain at least 5cm, otherwise two sensors will be affected by each other and not able to function.

## F2.5 Main Control Board Parameters Setup

### F2.5.1 Enable this function in Special function list

Chart F2.2 Door advance open/Re-leveling Function Enable Setup

Function Number	Definition
F4-06-19	ON; Re-levelling enable; OFF:Re-levelling disable.
F4-06-20	ON; Door open in advance enable; OFF; Door open in advance disable.

### F2.5.2 Running Parameters Setup

There are 3 parameters related to door open in advance/re-leveling function.

1. Advance door open elevator speed (F1-07); After elevator enter door zone in normal running, the elevator speed at advance door opening.
2. Re-leveling speed limit (F1-08); In the process of advance door opening and re-leveling, if elevator speed is higher than this value, elevator will stop.
3. Re-leveling running speed (F1-09); Set the elevator running speed at re-leveling.

## Appendix 3 Parameters List

Chart F3.1 Controller Parameters & Factory Setting List

Parameter	Name	Default Value	Set Value
U0-00	Lower Limit	0	
U0-01	Upper Limit	0	
U0-02	Lower Slowdown 1	0	
U0-03	Lower Slowdown 2	0	
U0-04	Upper Slowdown 1	0	
U0-05	Upper Slowdown 2	0	
U0-06	Floor Data 1	0	
U0-07	Floor Data 2	0	
U0-08~68	Floor Data 3~63	0	
U0-69	Floor Data 64	0	
U1-00	Input Data	--	
U1-01	Input Bin	--	
U1-02	Input App	--	
U2-00	Output Data	--	
U3-00	Car Input Data	--	
U4-00	Run Times	0	
U4-01	Run Hours	0	
U4-04	CAN1SendAPP	--	
U4-05	CAN1ReceiveAPP	--	
U4-06	InterferApprais	--	
U4-07	Encoder Apprais	--	
U4-09	Loading Data		
U5-00	Ctrsoftware NO	--	
U5-01	DriveCodeVer	--	
U5-02	CpldEdition	--	
U6-00	Power	--	
U6-01	Ref Speed	--	
U6-02	Feedback Speed	--	
U6-03	Load	--	
U6-04	DC Voltage	--	
U6-05	Output current	--	
U6-06	temperature	--	
U6-07	Output torque	--	
F0-00	Total floor	6	
F0-01	Homing Floor	1	
F0-02	Fire floor	1	
F0-03	Parking floor	1	
F0-04	VIP floor	1	
F0-05	1 <sup>st</sup> floor indicator setting	1	
F0-xx	Xxth floor indicator setting	1~63	

Chart F3.1 Controller Parameters & Factory Setting List (Cont'd)

Parameter	Name	Default Value	Set Value
F0-68	64 <sup>th</sup> floor indicator setting	64	
F1-00	Car speed	1.60m/s	
F1-01	Motor speed	306r	
F1-03	Insp speed	0.3m/s	
F1-04	Start speed	0.01m/s	
F1-05	Leveling Speed	0.3m/s	
F1-06	Least Speed	0.5m/s	
F1-07	Open Door Speed	0.15m/s	
F1-08	Relevelst Speed	0.25m/s	
F1-09	Relvelrun speed	0.05m/s	
F1-10	Acceleration B1	0.4m/s <sup>2</sup>	
F1-11	Deceleration B2	0.4 m/s <sup>2</sup>	
F1-12	S Curve P1	0.4 m/s <sup>3</sup>	
F1-13	S Curve P2	0.4 m/s <sup>3</sup>	
F1-14	S Curve P3	0.4 m/s <sup>3</sup>	
F1-15	S Curve P4	0.4 m/s <sup>3</sup>	
F1-16	Zero Speed	1RPM	
F1-17	Leveling Adj	50mm	
F1-18	Load Adj	0	
F1-21	Drive mode	0	
F1-22	Two Door Mode	0	
F1-23	Fire Mode	1	
F1-24	Parallel No.	0	
F1-25	Twins Control	0	
F1-26	Group Control	0	
F1-27	Far monitor	1	
F1-28	Auto Parking	0	
F1-29	Load Enable	0	
F1-30	Open Delay Time	0	
F1-31	Brake Feedback	1	
F1-32	Solution Ladder Password	0	
F2-00	Brake ON Time	1s	
F2-01	Brake OFF Time	1s	
F2-02	Insp Brake Time	0.9s	
F2-04	Zero Time	0.21ms	
F2-05	Open Door time	5s	
F2-06	Open Delay Time	60s	
F2-07	Homing Time	60s	
F2-08	Door Run Time	8s	
F2-09	Beep Delay Time	0.15s	
F2-10	Enable Delay	0.4s	
F2-11	Lamp Off Time	15min	

Chart F3.1 Controller Parameters &amp; Factory Setting List (Cont'd)

Parameter	Name	Default Value	Set Value
F2-12	Over Time	45s	
F2-13	SmoothStart Time	1.0s	
F2-14	Start Time/Hour	00	
F2-15	Start Time/Minute	00	
F2-16	Stop Time/Hour	00	
F2-17	Stop Time/Minute	00	
F2-18	Start Time 1/Hour	00	
F2-19	Start Time 1/Minute	00	
F2-20	Stop Time 1/Hour	00	
F2-21	Stop Time 1/Minute	00	
F3-00	Input type	4024434279	
F3-01	Car input type	2147090191	
F3-02	Input select 1	19	
F3-03	Input select 2	22	
F3-04	Input select 3	23	
F3-05	Input select 4	24	
F3-06	Input select 5	25	
F3-07	Output select 1	0	
F3-08	Output select 2	11	
F3-09	Output select 3	12	
F4-00	Set Stop Floor1	4294967295	
F4-01	Set Stop Floor2	4294967295	
F4-02	TIM Stop Floor1	4294967295	
F4-03	TIM Stop Floor2	4294967295	
F4-04	Door Select A1	4294967295(1~32floor)	
F4-05	Door Select B1	0	
F4-06	Function Select	538458116	
F4-07	Function Select 2	570425388	
F5-00	Motor type	0	
F5-01	Poles	20	
F5-02	Rated Freq	16	
F5-03	Motor rated power	5.1	
F5-04	rated speed	96	
F5-05	V IN	280	
F5-06	L_phase	16.1mH	
F5-07	R_phase	2.4ohms	
F5-08	Rated FLA	12.0A	
F5-09	Non-load current	0	
F5-10	slip frequency	1.5HZ	
F6-00	Carrier Freq	8HZ	
F6-02	SpeedZoom	100%	
F6-03	DirSel	0	

Chart F3.1 Controller Parameters & Factory Setting List (Cont'd)

Parameter	Name	Default Value	Set Value
F6-04	Kp	1000	
F6-05	KI	600	
F7-00	PIMulEnable	0	
F7-01	PI1 Range	5	
F7-02	PI2 Range	0	
F7-04	PI3 Range	0.5	
F7-05	Kp1	1200	
F7-06	Kx1	900	
F7-07	Kp2	1000	
F7-08	Kx2	600	
F7-11	Kp3	600	
F7-12	Kx3	500	
F8-00	Encoder PPR	2048	
F8-02	PG Type	1	
F9-00	Max Torq Comp	0%	
F9-01	SPDSourceSel	2	
F9-03	Spderr Set	5%	
F9-11	Load Comp Enable	0	
F9-13	Load Source Sel	0	
F9-19	UP Comp Bias	0	
F9-20	DOWN Comp Bias	0	
F9-21	FULL Comp Pro	100%	
FA-00	StratKP	30	
FA-01	StratKI	750	
FA-04	ZeroKeepKP	180	
FA-05	ZeroKeepKI	550	
FA-08	PLKP	2500	
FA-09	PLTime	900ms	
FA-11	IntegralGain	800	
FA-12	FluxGain	125	
FC-00	Zpulse_Init	0	
FC-07	Kplreg	10000	
FC-08	Kxlreg	5000	
FC-13	AutoTuneModeSel	1	
FC-14	N Temp Alarm Ena	1	
FC-15	InitTuneEnable	0	
FC-16	CD DirSel	0	
FC-17	SPG signal similarity	60	
FC-18	Output torque limitation	185	
FD-01	Single leveling sensor	0	
FD-02	UPS Open delay	15	10~30s
FD-03	IC Card Address	0	

Chart F3.1 Controller Parameters &amp; Factory Setting List (Cont'd)

Parameter	Name	Default Value	Set Value
FD-04	Maintenance cycle	0	0~1000 天
FD-05	Special function 3	0	
FD-06	Special function 4		
FD-07	Overload deviation coefficient		
FD-08	ARD running speed	0.2m/s	0.05~0.3m/s
A0-00	Language Sel	English	
A0-01	User Password	000000	
A0-02	Factory password	000000	
A0-04	Contrast	5	

## Appendix 4 Emergency Leveling Function

V9 series integrated controller is designed to work with elevator emergency leveling device to offer customers with the most reliable elevator emergency rescue solutions.

### F4.1 Emergency Leveling Device Model

Suitable Motor power:

SJT - YU - A; Below 7.5KW

SJT - YU - B:7.5-15KW

SJT - YU - C:15-22KW

Series; YU (Note; UPS Control)

### F4.2 Emergency Leveling Device Specification

1. Power Supply; AC220V $\pm$ 15%; 50HZ  $\pm$ 10%
  2. Power Output; AC220V $\pm$ 10%; 50Hz  $\pm$ 2%
  3. Ambient Temperature; 0 $^{\circ}$ C~40 $^{\circ}$ C
  4. Relative Humidity; 20~90%NO DEW
  5. Leveling Precision;  $\pm$ 15mm
  6. Suitable Motor Power; Type A; Below 7.5kW  
Type B; 7.5~15KW  
Type C; 15 ~22KW
  7. Maximum Running Time;  $\leq$ 2min
  8. Cabinet Dimension:SJT-YU-A/B/C:604\*247\*556 (Only for Reference)
- (Note; As UPS shape change from power rating, the emergency leveling device cabinet dimension is also different with power. Please contact supplier for actual cabinet dimension if needed. )**

### F4.3 Caution

1. F4-06-22 Set to "ON", emergency power supply should be 380V  
Set to "OFF", emergency power supply should be 220V
2. The effect of F4-06-22 parameter is that when the emergency power supply is 220V, the voltage of DC-bus will drop and cause low voltage fault; when emergency leveling input X18 is enable on integrated controller, the elevator will run in emergency leveling mode. At this time if the parameter is set "OFF", the integrated controller will by-pass such fault and continue the rescue operation.
3. If emergency power supply is 380V, or UPS output is 380V, please set the parameter to ON. Otherwise when X18 input signal is active, the controller cannot detect the voltage drop on main DC-bus and it cannot start the rescue operation.

## Appendix 5 Star-Sealed & Running Contactor

This function is used in the cabinet running contactor and machine internal Star-sealed contactor separately. To lower the cost, some customers ask to have a machine internal star-sealed contactor separately, and not choose the contactor of our standard layout. In this case please use this function.

When machine internal star-sealed contactor and running contactor are used separately, please set the integrated controller parameter F4-06-29(FU-29) to "ON", then the controller will automatically increase the output (Y8) and feedback input (X11) of machine internal star-sealed contactor. When running contactor acts, machine internal star-sealed contactor will be operated too. If you use this function, and X11 of controller does not receive the feedback signal of machine internal star-sealed contactor action, fault ER33 will be triggered to report machine internal star-sealed contactor feedback fault.

When pressing on the running contactor, machine internal star-sealed contactor will open after detecting the action of running contactor. This is to prevent system short-circuit at motor forced auto tuning with running contactor by-passed intentionally.

Star-sealed contactor (normally closed) has an action delay of 300ms (after delaying it remains closed condition). This way system can make sure the running contactor close 300ms earlier, then close star-sealed contactor to protect the machine. This is to prevent Star-sealed contactor close before running contactor not completely open and causes machine to short-circuit.

Star-sealed contactor and running contactor wiring diagram is shown below;

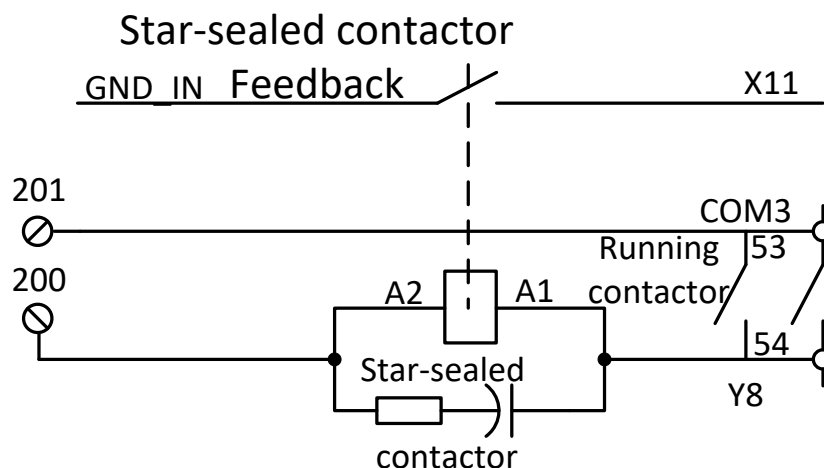

Figure F5.1 Wiring diagram



Please refer to final wiring diagram of the system for detail wiring, this drawing is only a reference for Y8 output and X11 feedback connection.

## Appendix 6 V9 Series Elevator Integrated Controller Intensive Serial Communication Resolution

Intensive serial communication function is only valid for controller with software version 7001 and above, and its detail function description and setting method as follow;

Setting F4-07-02 as ON, top limit and bottom limit signals are not necessary to be wired in hoistway cable, and 2 cables will be saved.

Top terminal and down door zone signals are active at the same time, and up door zone is not active, system will generate a top limit signal automatically; Bottom terminal and up door zone signals are active at the same time, and down door zone is not active ,system will generate a bottom limit signal automatically.

For controller with software version 7001 and above, and with the use of BL2000-CZB-V10, CAN bus controlling COP door open or close can be achieved. In this way, 5 cables of two door open /close signals and their common terminal will be saved.

**Chart F6.1 BL2000-CZB-V10 COP serial door open/ close function setup steps**

Jumper 1	Jumper 2	Jumper 3	Jumper D	
Yes	Yes	Yes	No	Setup COP

Firstly, setup COP function by jumper 3, 2, 1 and D. COP buzzer beep two times, and COP enters to setting mode. Now, door open 1 button state indicates that serial door open/ close function has been enabled or disabled. Door open 1 button light on means serial door open/ close function has been enabled; Door open 1 button light off means serial door open/ close function has been disabled. Press door open 1 button to switch the two states. After setting up, remove the jumpers, and the setting value will flash 3 times. At the same time, buzzer beeps 3 times, then COP saves the setting, and quit the setting mode.

When serial door open/ close function has been enabled, door open 1 relay, door open 2 relay, and door close relay use the same common terminal(J11-6). J11-5 is door close relay output, J11-9 is door open 1 relay output, J11-10 is door open 2 relay output. Y2~Y5 relays on board still output door open/ close signals synchronously with COP door open/ close signals output and can be used to observe the state of door open/ close commands on CAN bus.

Electric lock command and fire command are added into the CAN communication between integrated controller and HOP. With BL2000-HAH-M1.1, FR2000-HAH-V9, BL2000-HAH-B9 dot matrix display HOP, serial bus controlling lock and fire mode can be achieved. In this way, 2 cables of electric lock and fire signal and their common terminal in hoistway cables can be saved.

Serial fire and electric lock functions setup method; Short circuit the “DS” jumper.



For one elevator, only one HOP board can short the “DS” jumper. If lock floor and fire floor are not at the same floor, please wire to other floor HOP board from this board.

**IMPORTANT**

BY0-3 24V Common Terminal      BY0-4 Spare input 0

BY1-3 24V Common Terminal      BY1-4 Spare input 1

Default; Spare input 0 is electric lock input; Spare input 1 is fire input.

Integrated controller main board parameters should be set as follow;

F4-07-03 setting as ON, serial electric lock function is enabled.

F4-07-04 setting as ON, serial electric lock type is reversed.

F4-07-05 setting as ON, serial fire function is enabled.

F4-07-06 setting as ON, serial fire type is reversed



**Serial fire signal has been enabled, main board fire signal (X12) is still available, both of the two signals can bring the elevator into fire mode.**

**IMPORTANT**



**If main board enables the serial electric lock and serial fire function, but it has no wire to HOP or jumper “DS” on HOP board is not shorted or communication is interrupted, the elevator cannot enter into electric mode or fire mode.**

**IMPORTANT**

## Appendix 7 Menu operation processes with 4 Digital tubes & 3

### operation keys

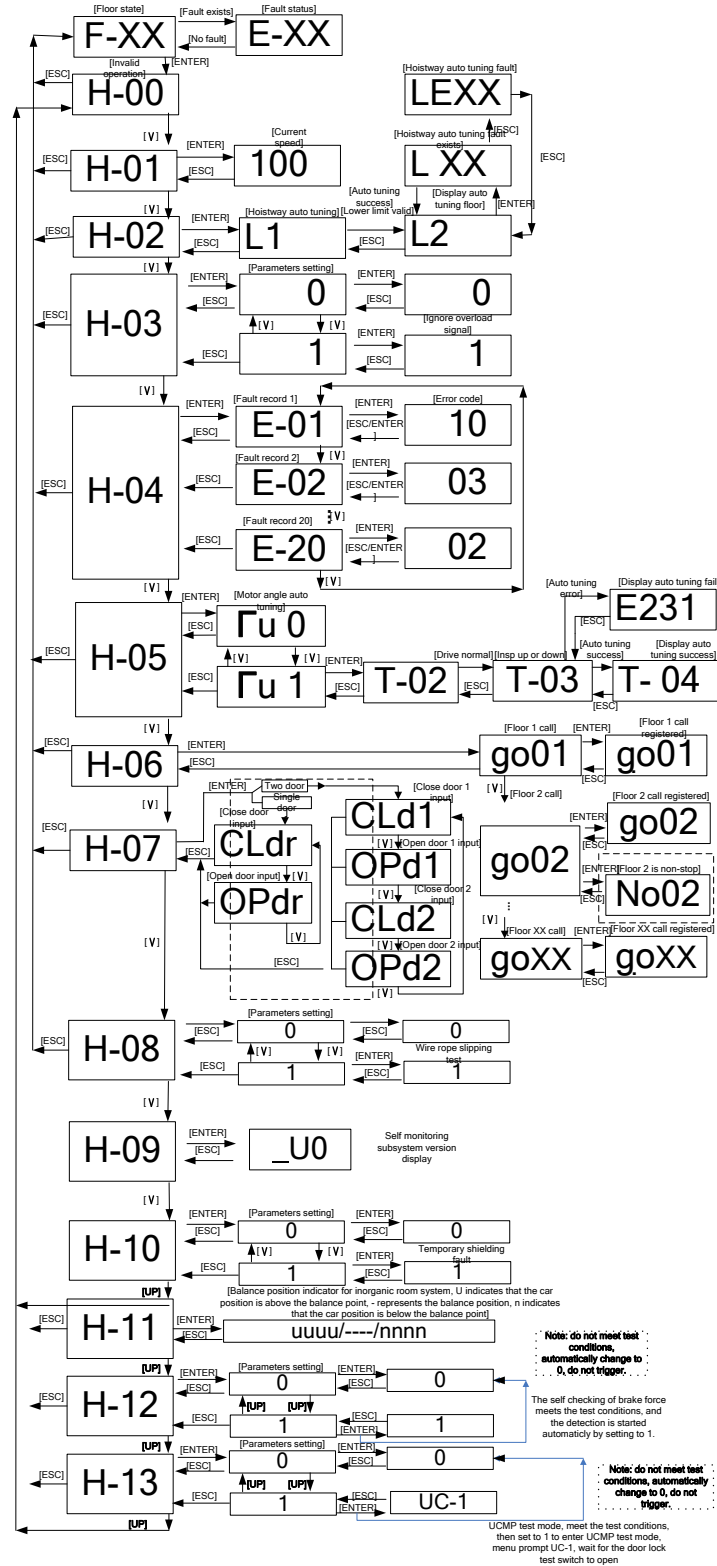

Figure F7.1 Setting flow chart

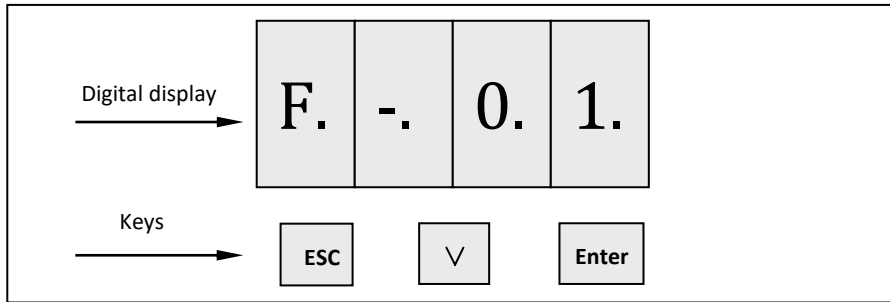

Figure F7.2 Display and key layout

There are 4 sets of segment displays on the main board, each set has a dot (from version 7125 starts, these dots are used to indicate elevator state information).

Under normal state without error (Inspection, Manual, Used, Fire, Stop);

- First dot represents front door light curtain and safety edge signals. Signals are valid, dot lights on. Dot turns off when signals are invalid;
- Second dot represents rear door light curtain and safety edge signals. Signals are valid, dot lights on. Dot turns off when signals are invalid;
- Third dot represents inspection signals via CAN communication (car top and pit). Communication inspection signal is valid, dot lights on. Dot turns off when signals are invalid.
- Fourth dot is reserved.

ESC; Cancel/return key;

▽; Flip key;

ENTER; OK key;

1. Normally, display current floor F-XX;

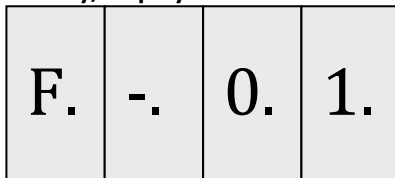

2. Digital tube flashing display error code when fault occurs.

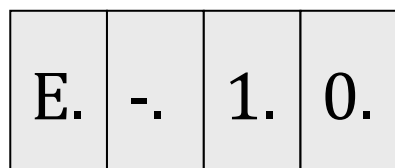

3. Press ENTER key and Flip key to select H-00~H-07 parameters;

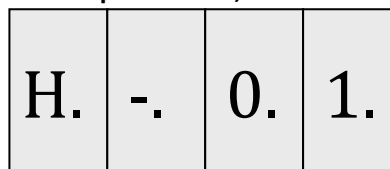
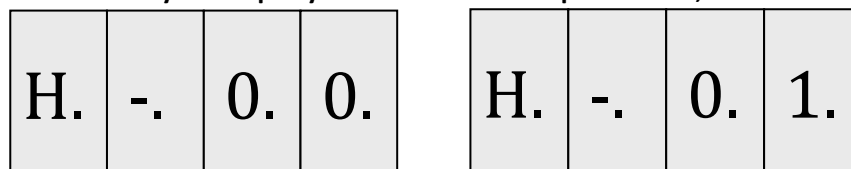

... ..

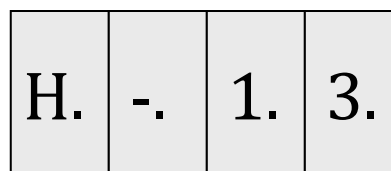
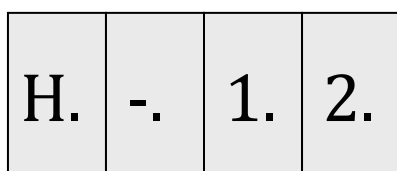

4. H-00; Invalid parameter;
5. H-01; Display current running speed (Unit; cm/s);

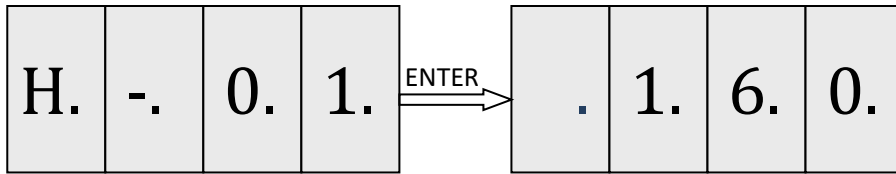

6. H-02; Hoistway parameter self-learning;

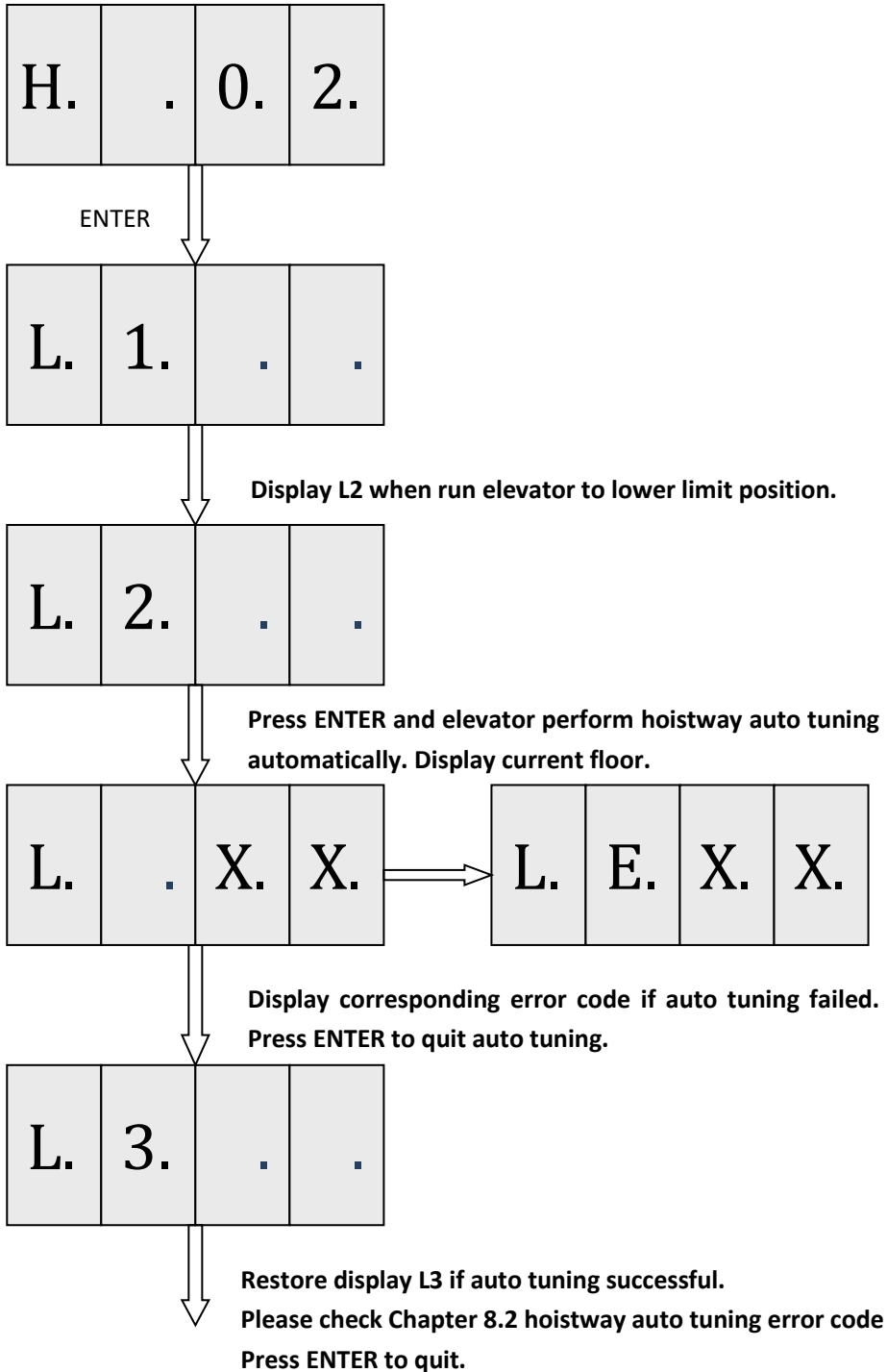

7. H-03; Temporary shielding overload signal, which is used for fast shielding of overload signal when running with 125% loads. This parameter is not saved. Power off, fault or exit from the menu will automatically reply overload signal.

H-03=1 Shielding overload signal (including switch weight and analog weighing)

H-03=0 Unshielded overload signal.

(This function is included by 1\*\*0\_7013 or 1\*\*0\_7113 and later version, refer to U5-00 for software number.)

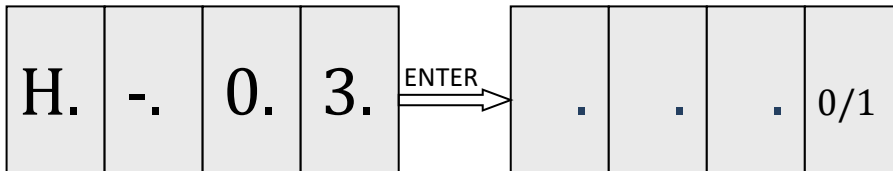

8. H-04; View 30 fault recodes.

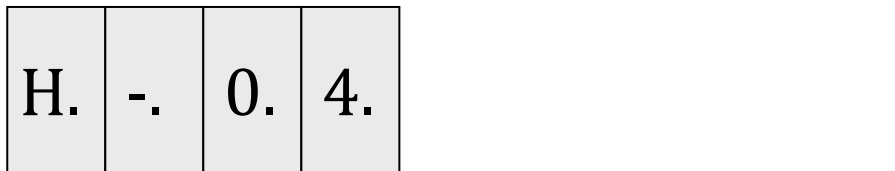

Fault No.                      Error code (Please check Chapter 8.1 elevator system faults)

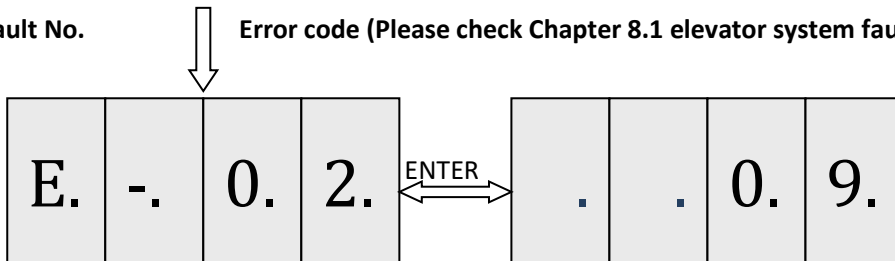

.....

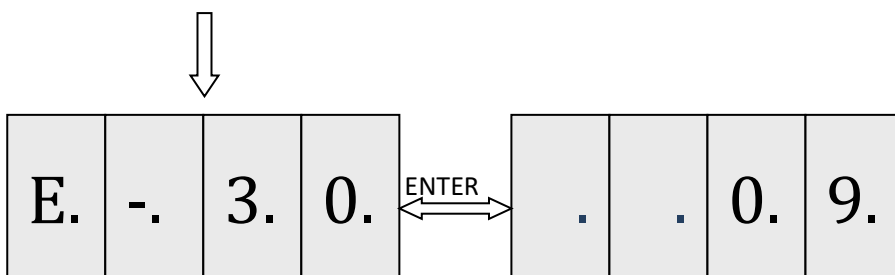

9. H-05; Motor static angle auto tuning

H.	-.	0.	5.
----	----	----	----



H.	5.	-.	0/1.
----	----	----	------



Choose 1, press ENTER to enter motor auto tuning mode.

T	-.	0.	2.
---	----	----	----



After drive microcontroller answer normal, display is shown below;

T	-.	0.	3.
---	----	----	----



Keep pressing jog up or jog down to rotate motor 3 circles.

Auto tuning fault

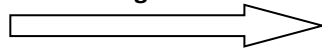

E.	X.	X.	X.
----	----	----	----

Handling according to error information prompted.

T	-.	0.	4.
---	----	----	----

Auto tuning proceeds gradually.

Press ENTER to quit.

## 10、 H-06:Car call input

H.	-.	0.	6.
----	----	----	----

↓ Enter (Enter car call input)

g.	o.	0.	1.
----	----	----	----

↓ up (select floor)

g.	o.	0.	2.
----	----	----	----

↓ enter (confirm selected floor)

g.	o.	0.	2.
----	----	----	----

Press Ecs to exit.

Note; if there is an abnormal condition (such as non-stop floor), the system will not be selected internally. At this time, the digital block will display as follows;

∏	o.	0.	2.
---	----	----	----

11、H-07:Open/Close door control

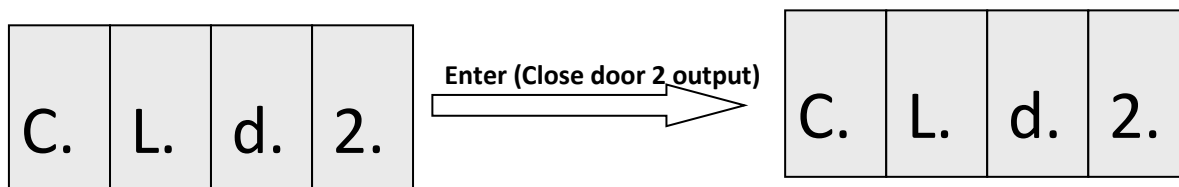
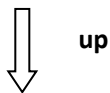
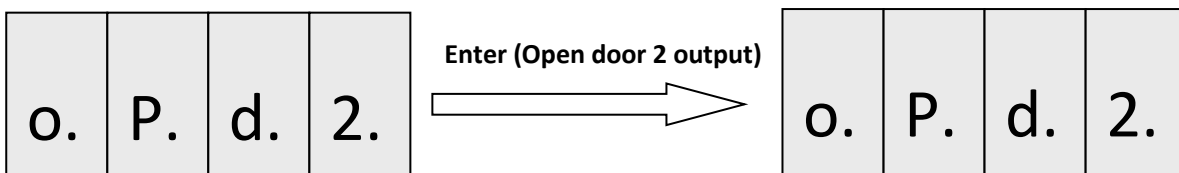
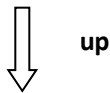
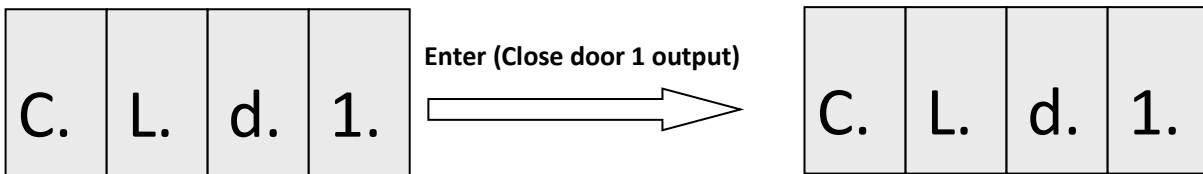
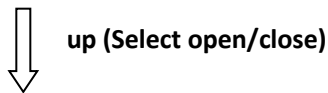
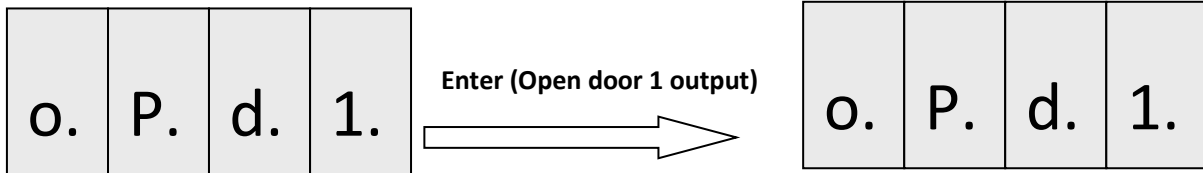
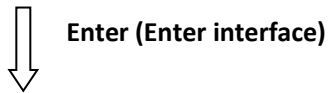
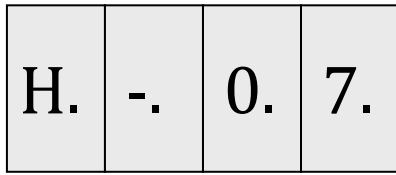

12、H-08:Temporary expansion of the electric torque and brake torque amplitude limit, while the output current will be amplified to the limit. It is specially used to test the slipping of wire rope. This parameter must be modified in the condition of inspection, and it is not allowed to save and power off, fault, withdrawal of the menu, or the recovery of automatic running will all automatically recover the related parameters. In this

mode, each running up in inspection mode, the parameter is automatically return to zero, if you want to run again, please reset the parameter to 1, and then retest by slow up/down key.

The limiting current is related to the rated current of the motor and the maximum output capacity of the power module of the integrated controller. If the maximum output current of the module is greater than 2 times of the motor rated current, the maximum output current of the module will be limited to 2 times of the motor rated current in order to avoid the damage of the motor. Otherwise, the output current will be output by the maximum output current of the module, so as to ensure that the whole power module is in the maximum output state when the wire rope slips.

H-08=1 Enter the testing mode of the wire rope slipping.

H-08=0 Exit the testing mode of the wire rope slipping.

(The controller version of the function is 1\*\*0\_7013 and 1\*\*0\_7113 and above. Please check U5-00 for version number.)

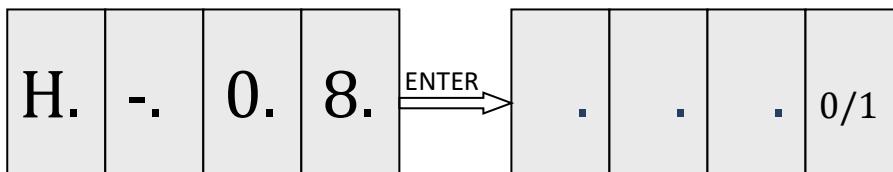

13、 H-09:Add a H menu to display the V0 version of the self-monitoring subsystem. H-09=\_\_U0; click the confirmation at the H-09 interface to show the \_U0.

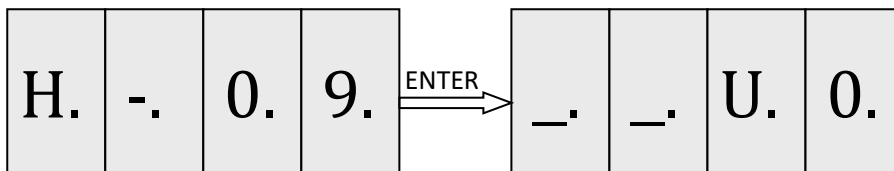

14、 H-10:The digital block small menu H-10=1 can temporarily shield the limit fault, run to the up/bottom limit in inspection mode, switch; H-10 interface click confirmation into the setting interface, default is 0, click UP key, change to 1, at this time run to the up/bottom limit in inspection mode. After the operation is finished, the value recovery to 0.

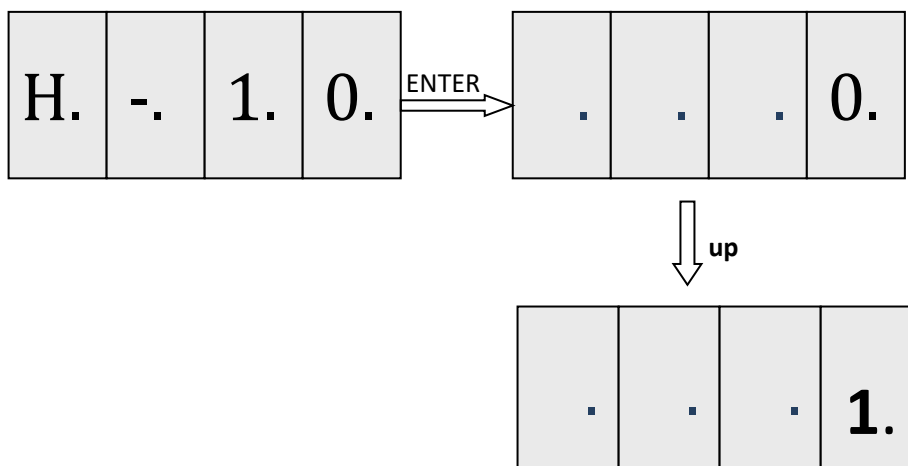

Press Esc to exit.

15、H-11: Balance position indicator of inorganic room system.

"U" indicates that the car position is above the balance point:

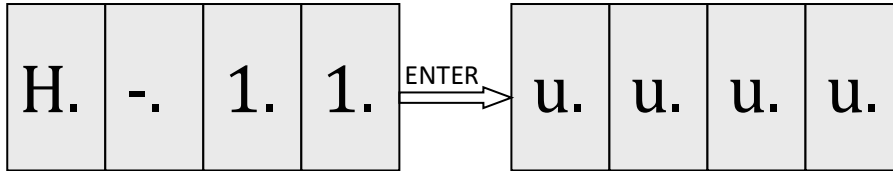

"-" means that the car is in a balanced position.

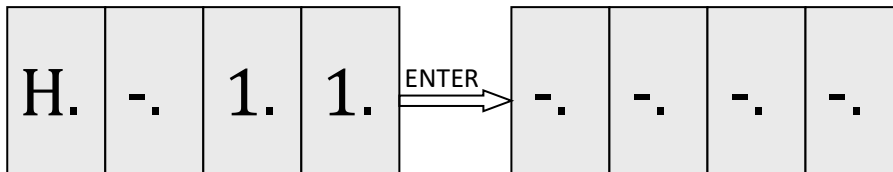

"N" indicates that the car position is below the balance point:

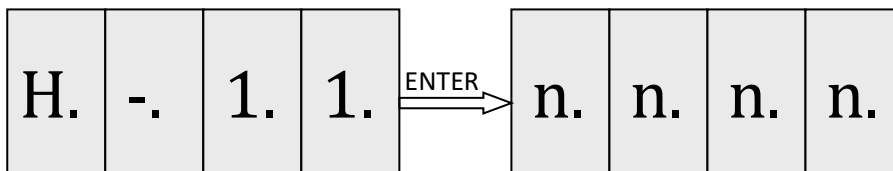

Press Esc to exit.

16、H-12:Self detection function of brake force.

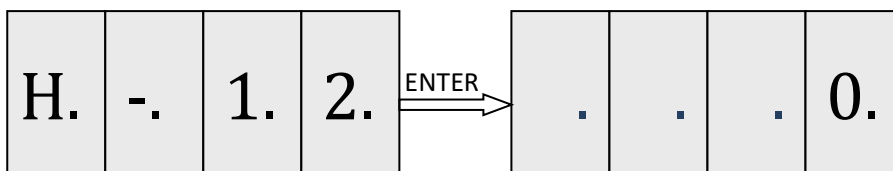

up



Satisfy the condition, change to 1  
Do self-detection of brake force automatically

ENTER

Do not satisfy the condition, change to 0  
Do not trigger self-detection of brake force



Press Esc to exit.

17、H-13:UCMP test mode.

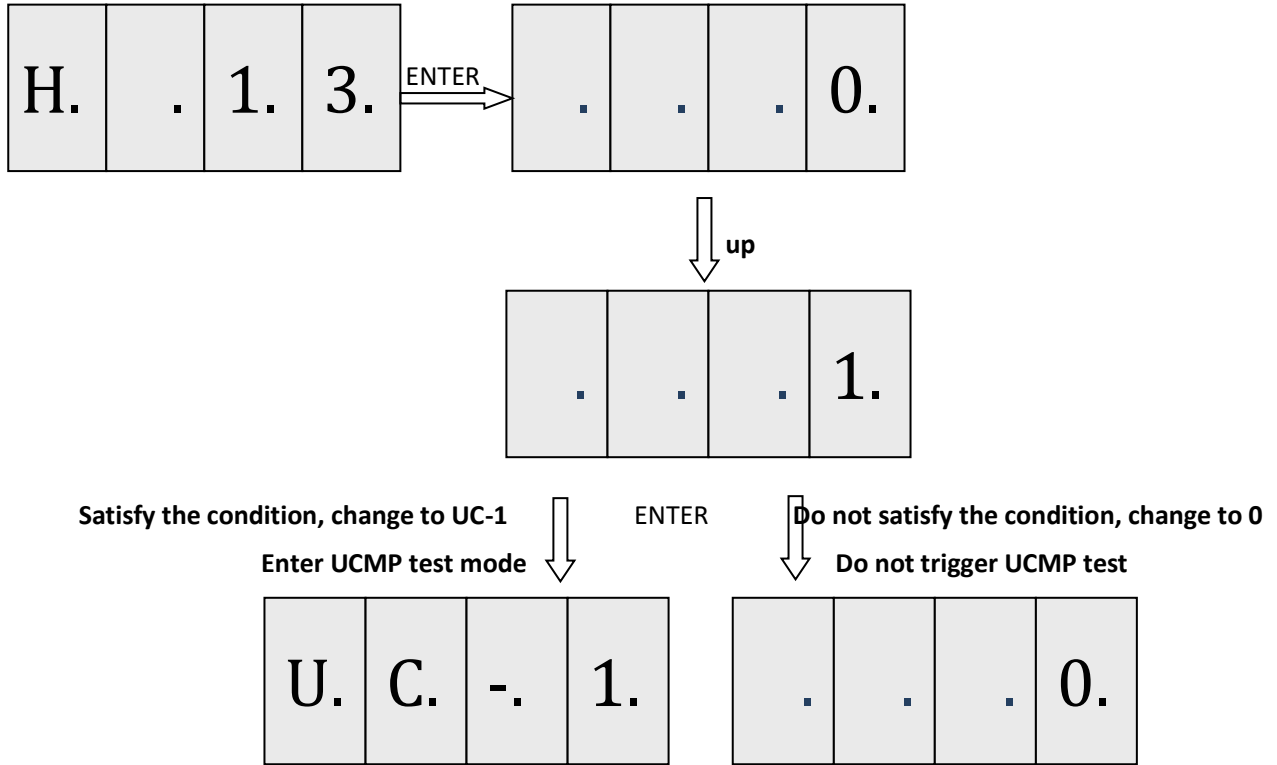

Press Esc to exit.

18、H-14:Set close limit type

Through mini keypad of mainboard H-14 menu, it can set door close limit 1 type and door close limit 2 type. When new elevator under installation, there's no car and car top. While shorting safety circuit and door circuit in cabinet, it may cause running failure by Er56 fault or door open because of no close limit. Then it can change door close limit type through H-14 menu to make door close limit valid. Then elevator can run normally. After debugging, please set door close limit type according to real condition.

H-14 setting value is same as setting to F3-01-04 and F3-01-06.

Exit setting menu, parameter will be saved automatically.

F7.2 C Group menu

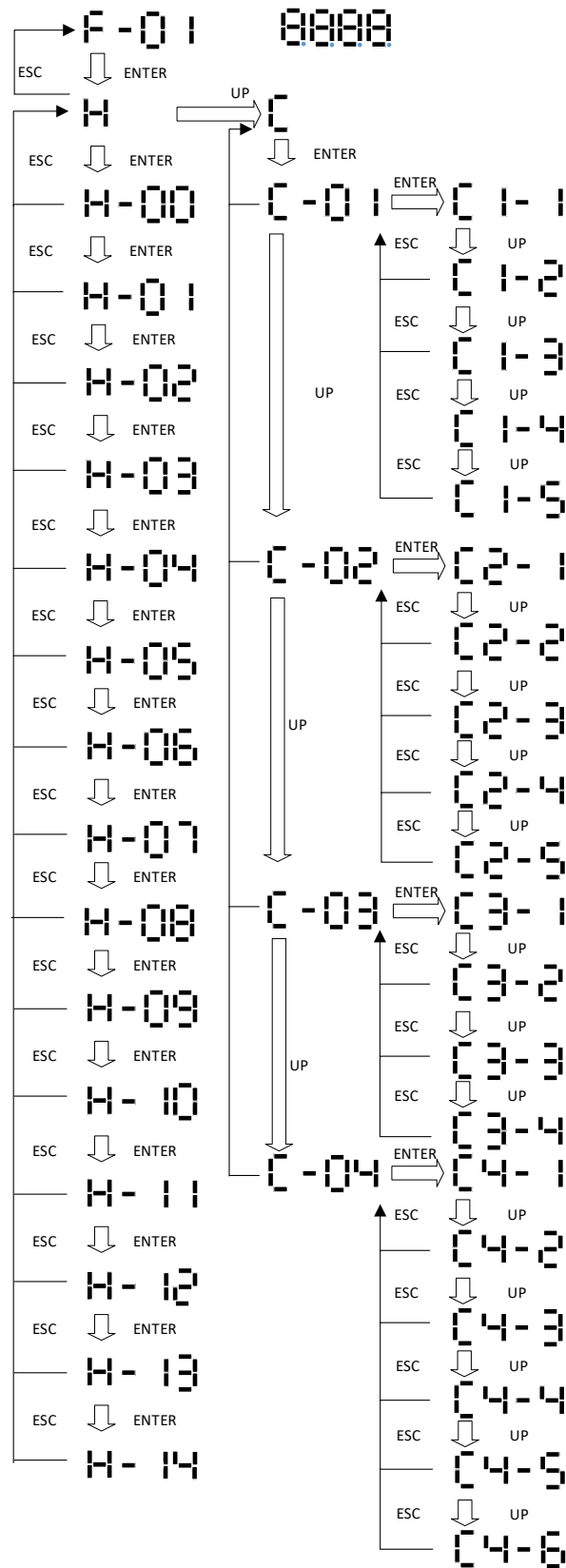

Figure F7.3 Flow Chart Diagram of mainboard segment and button combination

## Appendix 8 Separated Detection of hall door and car door for V9

In default setting, hall door circuit is series connection with car door circuit. If short hall door circuit or car door circuit, system will not find any error. Though this connection accord with elevator standard, it is lack of safety. BL6 integrated control add single detection of hall door. If short hall door or short both hall door and car door, system will show error. Only when hall door and car door both closed, system allow elevator to run. This will increase safety of the system. Besides, some customs need to cancel door circuit contactor in order to decrease cost, it also can be set by special function selection.

Use Function selection F4-06-12 to set if using X31 for hall door circuit detection.

Use Function selection F4-06-13 to set if having door circuit contactor.

**Chart F8.1 Setting of Separated Detection function**

Plan	F4-06-12 (Using X31 for hall door detection)	F4-06-13 (Canceling door circuit contactor, if set it to ON, F4-06-12 must be ON)	Description
1	OFF	OFF	Traditional detection. Contactor feedback (x14) + Door circuit (x30).
2	ON	OFF	Separated detection. Contactor feedback (x14) +Door circuit(x30) +Hall door circuit(x31). X31 for hall door detection.
3	ON	ON	Separated detection and cancel door circuit contactor. Door circuit (x30) +Hall door circuit (x31) . X30 for door circuit, x31 for hall door circuit.

➤ **Plan 1:F4-06-12=OFF F4-06-13=OFF**

Default setting, as Figure 1 (KMB means Door interlock contactor) :

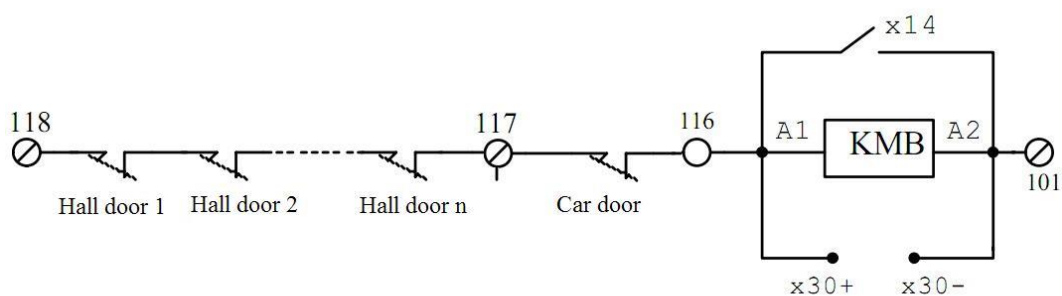

**Figure F8.1 Separated Detection Plan 1**

This plan is traditional detection plan, no separated detection of hall door and car door. If X31 is effective, it will show Error 62 to prevent wrong wiring error.

➤ **Plan 2:F4-06-12=ON F4-06-13=OFF**

Door circuit feedback is x14, x30 is for door circuit, x31 is for hall door. This plan can achieve separated detection, as in Figure 2 (KMB means Door interlock contactor);

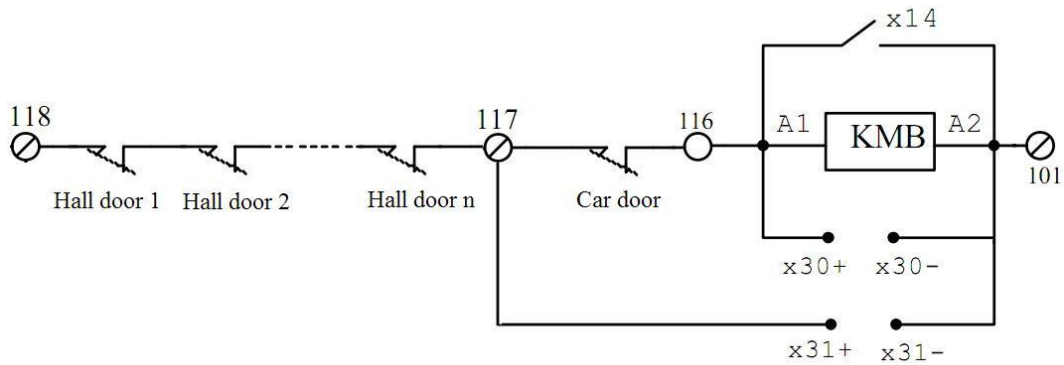

Figure F8.2 Separated Detection Plan 2

Once two of x14 & x30 & x31 are different, it will show error 26 after 3 seconds.

x31 is for hall door detection, x14 and x30 are for door circuit. If only short door circuit (116 to 118), the status of x31 will be different with x14 and x30, the elevator will not run.

When re-leveling or opening door in advance, x31 detection will be ignored.

➤ **Plan 3:F4-06-12=ON F4-06-13=ON**

x30 is for door circuit, and x31 is for hall door circuit. Door circuit contactor has been canceled, so no x14 feedback signal. As in Figure 3 (**KMB means Door interlock contactor**):

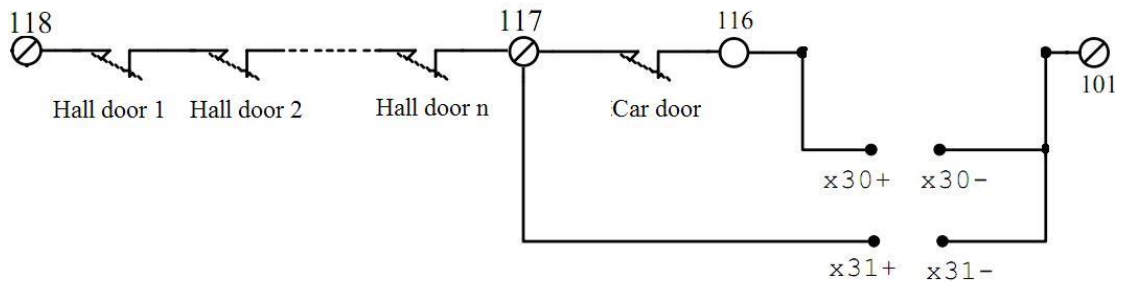

Figure F8.3 Separated Detection Plan 3

If the status of x30 is different with x31, system will show error 26 after 3 seconds.

x31 is for hall door, x30 is for door circuit. If only short door circuit(116 and 118), the status of x31 and x30 will be different, the elevator will not run.

x14 is not used. Then if x14 is effective, system will show error 62 to prevent wrong wiring.

When re-leveling or opening door in advance, x31 detection will be ignored.

## Appendix 9 Simple rated slip tuning for geared motor

### Tuning conditions;

1. Only suit for drive software 1xxx\_7x15 and above version.
2. Elevator must be operated with load (with rope).
3. Tuning type; FX-20=0. Each time after reset, this value will change to 1 automatically. So before rated slip tuning, this value must be set to 0.
4. Tuning start position is suggested to be floor 3 or above; Because tuning time may be long, ensure there's enough down running space for elevator cabinet.
5. Input basic motor parameters according to name plate of geared motor. No-load current is 30%~40% of rated current. Rated slip may be calculated by this following formula "Rated slip=Sync Freq – (Rated RPM \* poles/120)".

### Tuning steps;

1. Run elevator to level position of a certain floor ( floor 3 or above is suggested).
2. Do motor para tuning. After receiving para tuning command, it will show "waiting".
3. Press "DOWN" in inspection mode, then it starts to test and calculate rated slip value. When calculation complete, it will show "Success", then F5-10 will be renewed to calculated value. If fail, it will show an error code and keep F5-10 value.

Error code for rated slip tuning;

No.	Error code	Content
1	RF100	Before tuning, there's drive error, please solve error at first.
2	RF228	Tuning not complete, tuning end in advance.
3	RF1	Tuning deviation too large, please do tuning again.

4. Return elevator back to that certain floor in Step 1 (You may turn inspection to auto and run elevator back to that certain floor).
5. Repeat Step 1 to 3 and use the average value of 3 tuning results as final result.

## Appendix 10 V9 Series Elevator Integrated Controller UCMP (Unintended Car Movement Protection) Function Testing Procedure

Plan 1 (synchronous traction machine, no advance & re-level function and door opening pre-operation, using traction brake as trigger and stop subsystem plan.)

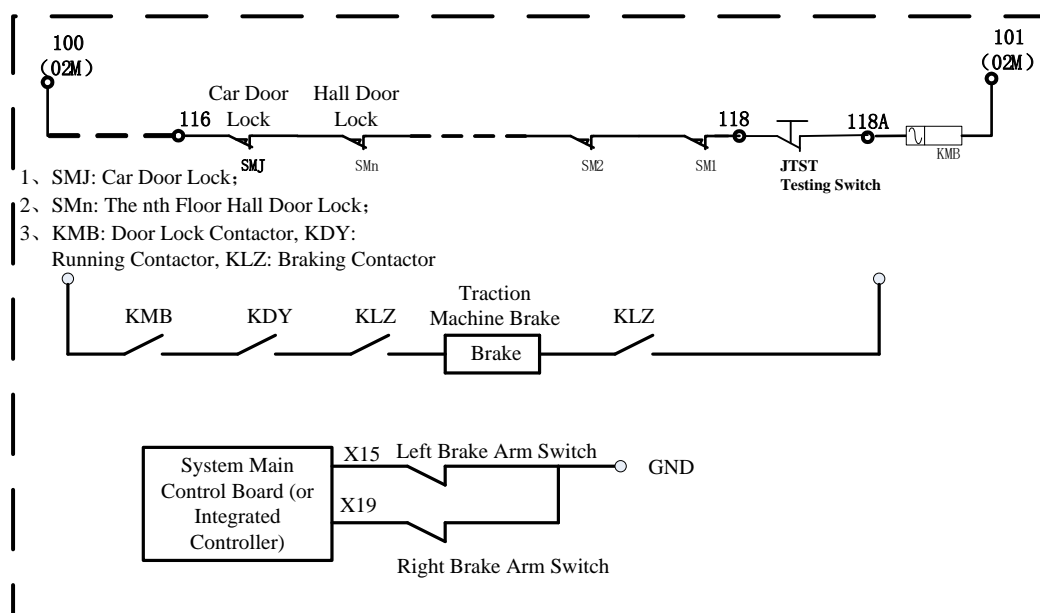

Figure F10.1 Control Loop Diagram of the Braking System

### Instruction;

1. For elevators that do not have functions to open the door in advance or while car is in leveling, re-leveling or other operations, under certain conditions, and the braking device is operated by a well standard approval machine brake. Testing of unintended car movement is not required. (If a testing is demanded, install additional switch according to figure F10.1. The test can be performed by manually opening the switch when elevator is in leveling position, inspection mode and leaving the leveling zoom. This scheme is to simulate the situation that car door or hall door is open. And prevent door mechanism break caused by really open it.)
2. Contacts from door lock safety loop directly control relays to open and close the brake.
3. According to No.1 Modification Document, the main control board is used as self-testing subsystem. And to detect the correctness of Lifting and Releasing motions performed by both left and right arms of the brake.

## Appendix 10. V9 Series Elevator Integrated Controller UCMP (Unintended Car Movement Protection) Function Testing Procedure

---

If the lifting and releasing motions are incorrect, an error is generated. System will close the door and stop elevator from running. The elevator must be reset by authorized people. Thus, since software version 14, x15 and x19 are set as feedback inputs of brake arms movement by default and cannot be turned off. For error caused by brake arms is not lifted when car starts, error code ER05, system resets this error after 5 seconds and retry normal operation up to 3 times. After 3 times, ER05 error is launched. For ER05 caused by incorrect brake arms releasing when car stops, system launch ER05 without reset or retry operations. When braking device has abnormal behaviors that are detected and logged, system sends close door command. If brake arm feedback switches are not recovered to correct states, door cannot be open. This prevents car slip while door is open that can cause shearing damage to passenger. Door can be open if brake arm feedback switches have recovered to correct states. After ER05 is launched and locked, system cannot reset this error by simply switch off power and restart. The reset method is; In inspection mode, press both inspections up and down buttons and hold for more than 5 seconds. Then ER05 can be cleared. (During reset, please make sure the indication lights of x1 and x2 are on which representing up and down keys are pressed and successfully launched. If they are not on, it might be caused by inspection switches from car carriage or car top are on and take over the priority of cabinet control.)

4. Check the braking force regularly during service. (Refer to attachment 1 for GT L integrated controller self-test function.)
5. If integrated controller is used as testing subsystem, one can activate braking force self-test function and check braking force daily according to attachment 1. If a malfunction of the brake is detected, system indicates ER39 error, close the door and shut down elevator. Reset must be performed by authorized people as describe above in 3. (In inspection mode, press and hold inspection up and down buttons for more than 5 seconds to clear the error.)

**Plan 2 (This Plan is for elevator system that is using Synchronous Traction Machine, has featured Advance Door Open function and Door Open Re-leveling function, and using Traction Machine Brake as the braking subsystem.)**

## Appendix 10. V9 Series Elevator Integrated Controller UCMP (Unintended Car Movement Protection) Function Testing Procedure

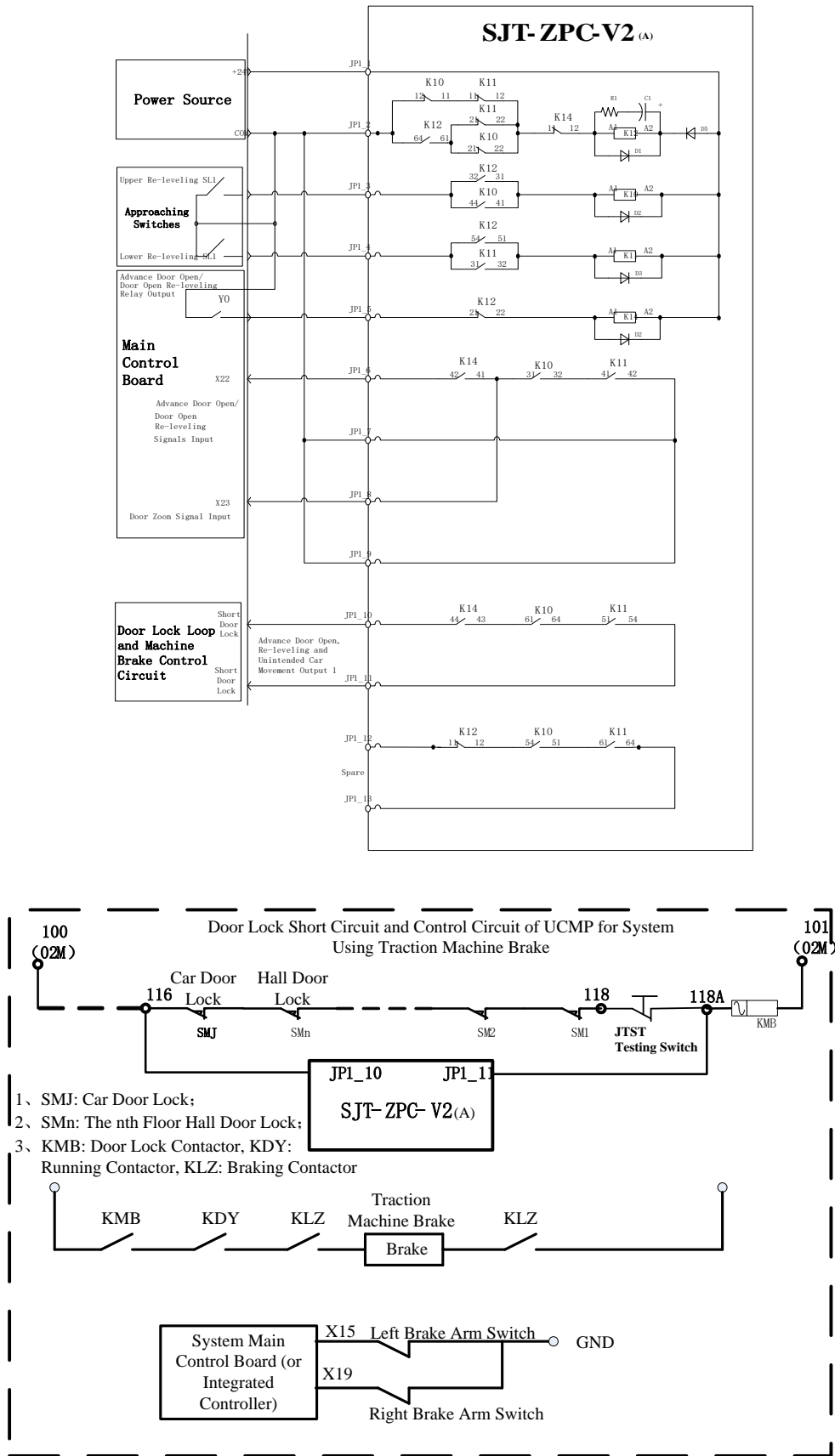

**Figure F10.2 System Structure Diagram and Connection Diagram**

## Appendix 10. V9 Series Elevator Integrated Controller UCMP (Unintended Car Movement Protection) Function Testing Procedure

---

### Instruction;

1. Using SJT-ZPC-V2A safety circuit board that integrates functions of controlling signals of Advance Door Open, Re-leveling and UCMP.
2. In door opening zoon, system controls the door open by short connect the door lock loop that satisfies conditions for advance door open and door open re-leveling.
3. When elevator leaves out of door opening zoon, safety loop is disconnected, and unintended car movement is detected. If the door lock safety contacts are open, system will cut off safety loop, shut down power supply and release the brake. Thus, unintended car movement can be protected.
4. According to No.1 Modification Document, the main control board is used as self-testing subsystem. And to detect the correctness of Lifting and Releasing motions performed by both left and right arms of the brake. If the lifting and releasing motions are incorrect, an error is produced. System will close the door and stop elevator from running. The elevator must be reset by authorized people. Thus, since software version 14, x15 and x19 are set as feedback inputs of brake arms movement (by default and cannot be turned off. For error caused by brake arms is not lifted when car starts, error code ER05, system resets this error after 5 seconds and retry normal operation up to 3 times. After 3 times, ER05 error is launched. For ER05 caused by incorrect brake arms releasing when car stops, system launch ER05 without reset or retry operations. When braking device has abnormal behaviors that are detected and logged, system sends door close command. If brake arm feedbacks switches are not recovered to correct states, door cannot be open. This prevent car slip while door open that can cause shearing damage to passenger. Door can be open if brake arm feedback switches have recovered to correct states. After ER05 is launched and locked, system cannot reset this error by simply switch off power and restart. The reset method is described as follow; In inspection mode, press both inspections up and down buttons and hold for more than 5 seconds. Then ER05 can be cleared. (During reset, please make sure the indication lights of x1 and x2 are on which representing up and down keys are pressed and successfully launched. If they are not on, inspection switches from car carriage or car top might be turned on and take over the priority of cabinet control.)
5. Check the braking force regularly during service. (Refer to attachment 1 for synchronous machine braking force self-inspection method and procedure.)
6. If integrated controller is used as testing subsystem, one can activate braking force self-testing function and check braking force daily according to attachment 1. If a malfunction of the brake is detected, system indicates ER39 error, close the door and shut down elevator. Reset operation must be performed by authorized people as describe above in 4. (In inspection mode, press and hold inspection up and down buttons for more than 5 seconds to clear the error.)
7. For control system using SJT-ZPC-V2A safety circuit board, we provide UCMP testing model. This is described in detail in attachment 2.

Appendix 10. V9 Series Elevator Integrated Controller UCMP (Unintended Car Movement Protection)  
Function Testing Procedure

Plan 3 (This scheme is for elevator system that is using Asynchronous Traction Machine and using Speed Governor includes Safety Gear, Rope Gripper and additional brake as the braking subsystem.)

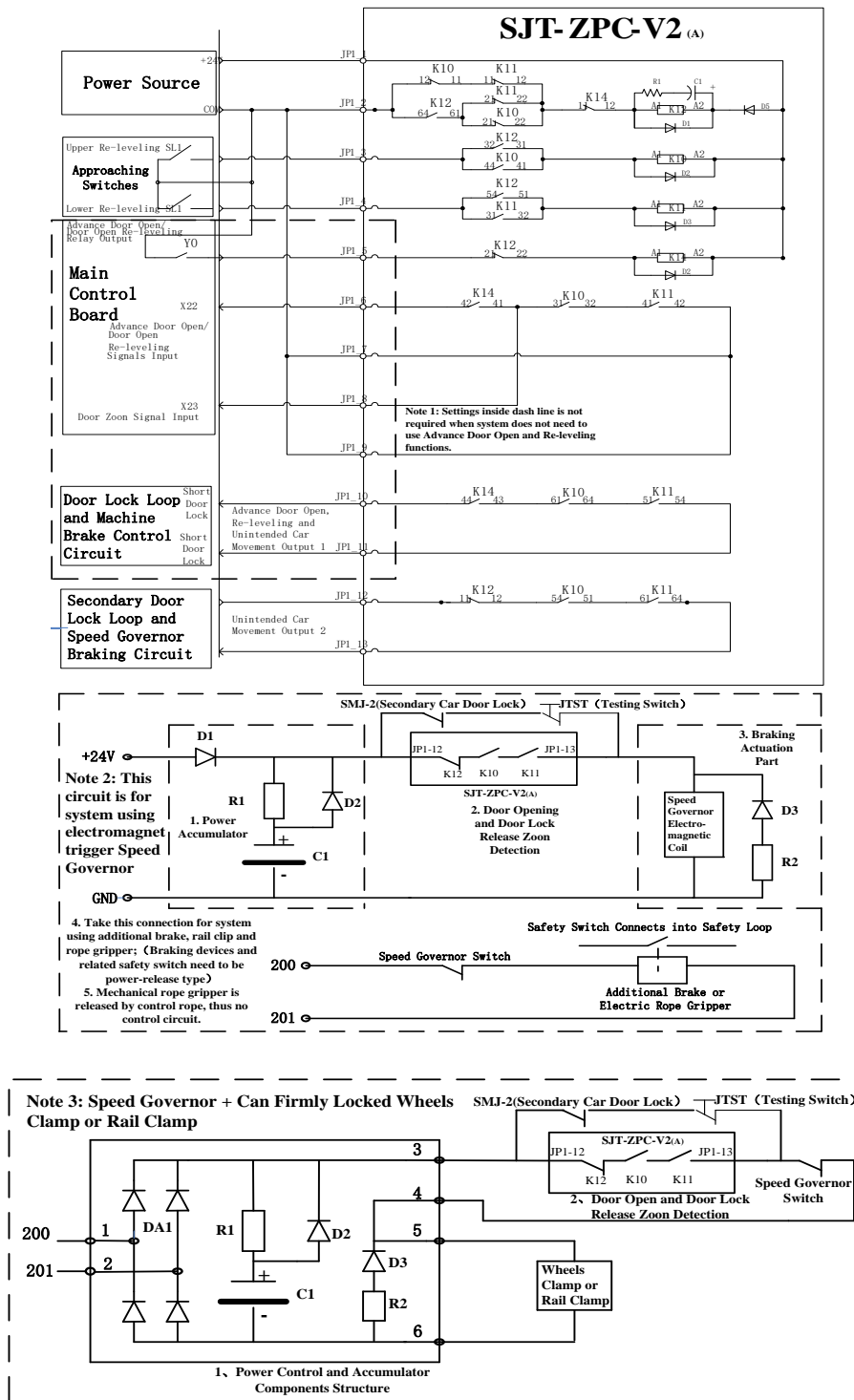

Figure F10.3 System Structure Diagram and Connection Diagram

## Appendix 10. V9 Series Elevator Integrated Controller UCMP (Unintended Car Movement Protection) Function Testing Procedure

---

### Instruction;

1. Using SJT-ZPC-V2A safety circuit board that integrates functions of controlling signals of Advance Door Open, Re-leveling and Unintended Car Movement.
2. In door opening zoon, system controls the door open by short connect door lock loop that satisfies conditions for Advance Door Open and Door Open Re-leveling.
3. When elevator leaves out of door opening zoon, safety loop is disconnected, and unintended car movement is detected. If the door lock safety contacts are open, system will cut off the safety loop, shut down power supply and release the Speed Governor. Further car movement will activate Speed Governor to brake the car by Safety Gear, Rope Gripper and additional brake.
4. After Speed Governor, Safety Gear, Rope Gripper and additional brake activated, they will turn off safety switches. That must be reset by authorized people.
5. According to No.1 Modification Document, the main control board is used as self-test subsystem. And to detect the correctness of Lifting and Releasing motions performed by both left and right arms of the brake. If the lifting and releasing motions are incorrect, an error is produced. System will close the door and stop elevator from running. The elevator must be reset by authorized people. Thus, since software version 14, x15 and x19 are set as feedback inputs of brake arms little movement by default and cannot be turned off. For error caused by brake arms is not lifted when car starts, error code ER05, system resets this error after 5 seconds and retry normal operation up to 3 times. After 3 times, ER05 error is launched. For ER05 caused by incorrect brake arms releasing when car stops, system launch ER05 without reset or retry operations. When braking device has abnormal behaviors that are detected and logged, system sends door close command. If brake arm feedbacks switches are not recovered to correct states, door cannot be open. This prevent car slip while door open that can cause shearing damage to passenger. Door can be open if brake arm feedback switches have recovered to correct states. After ER05 is launched and locked, system cannot reset this error by simply switch off power and restart. The reset method is described as follow; In inspection mode, press both inspections up and inspection down buttons and hold for more than 5 seconds. Then ER05 can be cleared. (During reset, please make sure the indication lights of x1 and x2 are on which representing up and down keys are pressed and successfully launched. If they are not ONs, inspection switches from car carriage or car top might be turned on and take over the priority of cabinet control.)
6. Featured with power accumulator. Car emergency brakes in a short period of power shut down. The braking subsystem will not activate if the car door keeps closed. This prevents incorrect braking triggered by power off.
7. Accidentally or in inspection operation mode, opening hall door will not trigger braking subsystem.

**Appendix 10. V9 Series Elevator Integrated Controller UCMP (Unintended Car Movement Protection)  
Function Testing Procedure**

8. Attention; control component and accumulator of the power system (includes their parameters), trigger and brake of the braking subsystem need to be provided by correlated factory.
9. For control system using SJT-ZPC-V2A safety circuit board and asynchronous traction machine, UCMP testing method is described below; In inspection operation mode, close the main and sub door lock loops, break the testing switch to simulate that door is open. Press inspection up or down keys to move car out of door safety zoon. Then the safety loop detects sub door lock loop is broken and activates braking subsystem. (Car stopped by releasing rope gripper or rail clip.) After test, reset all braking mechanism and the testing switch.

**Attachment 1. Braking force self-test function of system using synchronous traction machine.**

Insufficient braking force is a high potential risk of elevator failure. IECS system provides braking force self-test function to check braking force efficiently and prevent elevator failure caused by insufficient braking force. In regular operation, elevator runs a braking force self-test once a day. If insufficient braking force is detected, system stops elevator and generates error warning. Moreover, braking force self-test can be operated via a smart phone or a handle operator during tuning on site or in service.

Parameters that need to be set are shown below;

FD-26	Balance coefficient of elevator range from; 40~50. (Unit, %)
FD-27	The radio of the output current when elevator is empty loaded and travelling downward, to the rated current of motor, ranged from; 30~130. (Unit, %)
F4-07-27	ON:Enable the braking force self-test function. The elevator is in the "automatic" state, checking whether the elevator is in idle at 3am every day. If the elevator is in the idle state, it automatically activates the braking force self-test function. (for IECS functional version)
FD-05-13	Single brake force test enable. After setting to ON, brake force testing will seperate to several times for each brake individually.

Manual brake force testing can be achieved through setting F4-07-30 on keypad or mini keypad C4-4 on mainboard:

F4-07-30	Parameter of manually triggered braking force self-test function. First, function F4-07-27 must be set to ON and turns on braking force self-test function. Then this parameter is used in inspection operation to trigger braking force test manually. Every time this parameter turns from OFF to ON, a braking force self-test is performed. Maintaining in ON state will not trigger this action (for version 71xx with IECS function).
C4-4	Use mini keypad on mainboard can also start testing. Enter test menu C4-4, press "UP" button to make segment display change from"0"->"1", then press ENTER to start.

## Appendix 10. V9 Series Elevator Integrated Controller UCMP (Unintended Car Movement Protection) Function Testing Procedure

---

Manual brake force testing process;

Turn elevator to inspection or emergency running mode and close door, make sure there's no other fault except safety circuit fault.

Use mini keypad or operator to trigger brake force testing, then turn inspection or emergency running switch to normal within 10 sec to recover safety circuit.

After automatic or manual trigger testing, it will show "b1--"~"b6--" on segment 自 display of mainboard and show testing result "SUCC"OR"FAIL"while testing complete.

"b1--":Running contactor turn on, star-sealed contactor turn on, and single side of brake contactor turn on to open one side of brake

"b2--":Inverter output testing torque, this process keeps for 5 sec about.

"b3--":One side of brake testing complete. Running contactor, star-sealed contactor and brake contactor all cut off, brake turn off.

"b4--": Running contactor turn on, star-sealed contactor turn on, and the other side of brake contactor turn on

"b5--": Inverter output testing torque, this process keeps for 5 sec about

"b6--": The other side of brake testing complete. Running contactor, star-sealed contactor and brake contactor all cut off

"SUCC":Testing complete, the brake force reach the standard, then it will show test value of brake force.

"FAIL":Test fail, brake force doesn't reach the standard. System will show E-39 fault.

"bA--":Safety circuit open, please recover emergency switch or inspection switch

After testing complete, if the brake force reach the standard, mainboard will show "SUCC"andthen current testing threshold "105"for 3 seconds. If testing fail, it will show "FAIL" and "E-39" fault.

If brake force testing fail and show Er39, which means brake force is not enough. It can only be reset by professional person through special operation. Power off and power on will not reset the fault. Fault reset method; Check brake at first, adjust braking force and then turn to inspection mode, keep pressing Up and Down for 5 sec. The fault code will be cleared. After resetting fault, it is suggested to manually trigger several times to confirm the brake force already meet the standard.

After automatically or manually triggered self-test, you will observe that inside of control cabinet, running contactor is closed, star contactor is closed, and brake contactor is not activated (released brake). Then the sound of inverter outputting current can be heard, this indicates the inverter is outputting testing torque, this process is about 10 seconds. After completion, if there is no error warning on handle operator (F4-07-30 at the end of test will not turn automatically from ON back OFF, if you want to test again, please turn this parameter to OFF first and then to ON, then this function is triggered again. This parameter is not allowed to be saved and the save operation is invalid), it means the braking force self-test is performed successfully. If a smart phone is used to operate the test, you will see the success notice from program.

**Appendix 10. V9 Series Elevator Integrated Controller UCMP (Unintended Car Movement Protection)  
Function Testing Procedure**

If any fault of braking force is detected, error code "ER39" indicates braking force is insufficient. The brake must be checked first, and the braking force should be adjusted to recover the fault. After recovery, it should be manually triggered several times in inspection mode to confirm that the braking force has been adjusted to meet the requirements.

There are two methods to recovery of this fault;

1. If insufficient braking force is detected by regulated timing self-test in "automatic" mode. This failure must be reset by a professional on site through the following specific actions. Simple switch off power and restart the system will not clear this error, and the system keeps in locked. The reset process is as follows; in inspection operation mode, press and hold inspection up and down buttons for more than 5 seconds, the fault code will be cleared.
2. If this error occurred in inspection operation mode via process described in "F4-07-30" above or the braking force test was manually triggered from smart phone program "elevator expert". 5 seconds after generated this fault, it will be automatically removed.

**Attachment 2. the UCMP function testing procedure for system using  
synchronous machine with safety circuit board.**

Gearless Motor;

1. Before test, ensure the following conditions are met; (1) the elevator is in door leveling zoon, (2) the upper and lower door zoon signals (x9, x10) are valid, (3) upper and lower safety door zoon signal (x23) is valid, (4) the elevator is in inspection mode, (5) hall door and car door are closed, the door lock loop is closed, (6)currently, system has no error, (7) at least one of F4-06-19 and F4-06-20 is set to ON, since at least one of the Advance Door Open and Door Open Re-leveling functions needs to be enabled.
2. In digital operator settings menu, set the F1-21 drive mode to 4, the segment display on mainboard shows UC-1, which means entering to UCMP test mode. If it cannot be set to 4, please check the conditions in "1".

U.	C.	-.	1.
----	----	----	----

3. Within 10 sec, use UCMP test switch to cut off door circuit, then select suitable running direction and press UP or DOWN button according to car location (for example, select up running at bottom floor, and select down running at top floor).
4. Once system detects door circuit open and runing button is pressed, after safety circuit is closed, it will bridge door circuit again through SJT-ZPC-V2A safety board. And segment display on mainboard will show UC-2 at same time.

U.	C.	-.	2.
----	----	----	----

**Appendix 10. V9 Series Elevator Integrated Controller UCMP (Unintended Car Movement Protection)  
Function Testing Procedure**

---

5. After elevator starts running, the segment display on mainboard will show UC-3. Elevator will run at 0.5m/s or rated speed (the lower on of these two value).

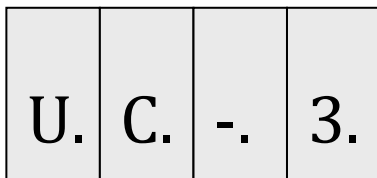

6. After the car runs out of safety zone, safety board will cut off door circuit(brake turn off) as safety zone signal lost. System will show fault Er60 and lock it. (Cannot be reset by power off. The reset method can be found in step 7). The segment display on mainboard will show E-60 and current floor F-xx in turn. System will exit UCMP test mode, F1-21 Drive Mode will turn back from 4 to previous value. The testing complete.
7. After testing, please recover UCMP test switch. After door circuit recover to close, keep pressing Up and Down button in inspection mode for 5 sec to clear Er60 fault and its lock. Then elevator recover to normal. Turn inspection to Auto, elevator will automatically run back to leveling position.

**Geared Motor:**

1. Move car to leveling position and close door, then turn to inspection mode. System should have no fault expect E-10.
2. Use UCMP test switch to cut off sub door circuit.
3. Open brake and let elevator slide. After sliding, because sub door circuit is open, the additional braking device (rope brake or rail clamp) will be at pretrigger status. After detecting sliding, it will immediately stop car. Then testing complete. For the elevator with advance open and re-leveling, after car slides out of safety zone, safety board will trigger additional braking device and stop car.
4. After testing, recover UCMP test switch, additional braking device and related safety circuit switch. Finally exit inspection mode and system will recover to normal running.

## Appendix 11 V9 Series Elevator Integrated Controller Rope Slipping Mode Testing

1. After setting FD-25 to 1, the system enters the slipping mode. At this time, pressing slow up / slow down button, the system will output the limiting current ,so that the limit slip state of the rope can be observed;
2. Please setting FD-25=1 first before making the rope slipping experiment. After the experiment has been finished, FD-25 will automatically be cleared to zero;
3. After setting FD-25 to 1, set the non 1 value again, that will be automatically cancel the slipping mode;
4. if you use Digital tubes & operation keys for operation, please refer to the step 12 (H-08) of **Appendix 7; Menu operation processes with Digital tubes & operation keys.**

## Appendix 12 Floor/Car Door Short-circuited Detection and The Plan for Bypass Operation Alarm

### F12.1. V9 Series Elevator Integrated Controller Floor/Car Door Short-circuited Detection Plan

#### F12.1.1. Relevant Requirements in National Standard 7588.1

- 5.12.1.9 Prevent the normal operation of the elevator when the door contact circuit fails.
- When the car is opened in the un-locked area and the floor-door lock is released, the system should check the electrical safety device in the position of car-door closed(5.3.13.2), check the electrical safety device in the position of floor-door locked (5.3.9.1) and the monitoring signal (5.12.1.8.3d).
- If the failure of the above device is monitored, the normal operation of the elevator shall be prevented.
- Rules for type test of control cabinet;
 

V6.2.8.7 The electrical protection of the floor-door lock device; when the car is stopped in the open area, the car-door is opened and the floor-door lock is released, the system should check the electrical safety device in the position of car-door closed, check the electrical safety device in the position of floor-door locked, and the correct action of the circuit should be checked. If the failure of these devices is detected, the normal operation of the elevator shall be prevented.

#### F12.1.2. Testing Plan for Single Door Elevator

- F4-06-12=ON>Select X31 high voltage input to detect car-door, conform to the new standard must be selected.
- F4-06-13=OFF; use the door lock contactor, ON; do not use door lock contactor (optional).
- A single door lift with a split-level open elevator (for example, the front door of the 1st floor and the rear door of the 2nd floor, both with the front and rear doors, but there is no floor through the door).

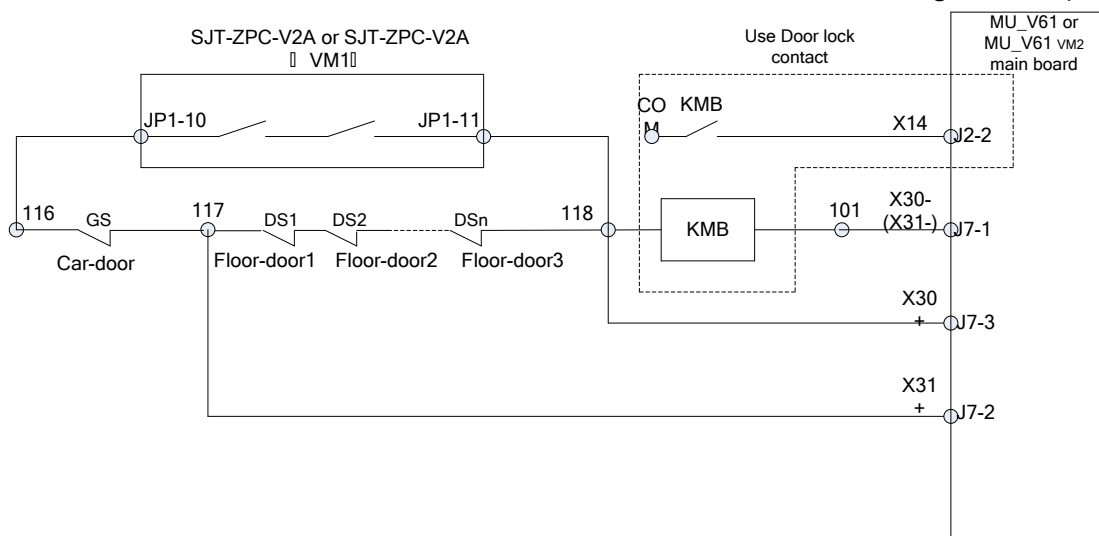

Figure F12.1 V9 Series Elevator Integrated Controller Floor/Car Door Short-circuited Detection Plan

Incorrect operation check of floor-door or car-door (floor-door be shorted, or car-door be shorted);

- As shown in figure F12.1, when the car-door is short connected (116 and 117), after the elevator opens, the car-door opens, but the car-door will be checked to be shorted, the X30 is invalid, the X31 is valid, the system will output No. 26 error, and the elevator cannot run with door closed.
- In order to accord with the new national standard (or new inspection rules), the floor-door or car-door is short connected, which can be detected effectively and stop normal operation. As shown in figure F12.1, a safety circuit board (SJT-ZPC-V2A or SJT-ZPC-V2A (VM1)) must be installed, and Advance Door Open function or Re-leveling function is required to be enabled. (F4-06-19 or F4-06-20 must be set to ON).
- While the elevator is running with advance door open or door open re-leveling function (Safety circuit board works, so the lock door opens) . when the door opens, it will detect whether the X31 and the closing door limit are released effectively. If the effective release does work, that proves floor-door and car-door, and the door-lock closing signal (door close limit) is correct. Next time the system will operate normally.
- During the elevator is running with advance door open or door open re-leveling function, if the X31 signal and door close limit are not released effectively, or After opening the door completely in un-inspection state, the main board will output Y0 signal to control the safety circuit board to short the door lock and check whether the X31 signal and door close limit are released, if not released, the system will output No. 92 fault (floor-door or car-door short circuit fault or adhesion of closing in place signal), forbid the elevator to continue operating normally, It is necessary to enter the condition of inspection or power-off to clear the fault.

### F12.1.3. Testing Plan for Double Door Elevator

- F4-06-12=ON:Select X31 high voltage input to detect car-door, conform to the new standard must be selected.
- F4-06-13=OFF; use the door lock contactor, ON; do not use door lock contactor (optional).
- F4-06-04=ON; the X32 input will be used to detect the signal between the car-door and the floor-door of the rear door, to detect whether the line is sealed, the two rear doors should be connected according to the figure F12.3. and the new standard must be selected.
- SJT-ZPC-V2A (VM1) safety circuit board must be used, SJT-ZPC-V2A (VM1) is a new type of safety circuit board, completely compatible with SJT-ZPC-V2A. As shown in figure F12.3, The new added terminal output JP1-14 both seals the front door and back door by two output signals. The SJT-ZPC-V2A (VM1) safety circuit board also has the functions of advance door open, re-leveling and Unintended car movement protection checking subsystem. SJT-ZPC-V2A (VM1) will replace SJT-ZPC-V2A safety circuit board.
- We must use MU\_V61 VM2 integrated Controller motherboard (or its corresponding OEM model), and MU\_V61 VM2 motherboard can be used to replace MU\_V61 motherboard. The MU\_V61 VM2 integrated Controller motherboard (or its corresponding OEM model) will replace the existing MU\_V61 motherboard (or its corresponding OEM type).
- **Double rear door uses the series connection plan ; front car-door → front floor-door → rear floor-door → rear car-door, which is only accord with the old standard or the old check gauge; floor-door (both front and back) → car-door (both front and back, with two accompanying cable and one well cable. In addition, we can use front floor-door → front car-door → rear car-door → rear floor-door to add an accompanying cable and two well cables. The customer can choose the cable according to the configuration of the cable, and the detection function will not be changed. In the case of all the rear door plans, the same explanation will not be repeated.**

➤ Note;

1. the synchronous and asynchronous traction elevator uses different plans with the SJT-ZPC-V2A (VM1) safety circuit board to realize the rear door lock detection, because the UCMP stop subsystem is different.
2. The synchronous traction elevator, using the brake as the stop subsystem, does not need to use the other output (JP1-12 and JP1-13) of SJT-ZPC-V2A (VM1). The rear door is connected to the middle of the door loop through the JP1-14 terminal is connected in series, which meets the standard requirement of the safety circuit. (any components in safety circuit board shall be no dangerous), whether or not the short connection detection will seal the door lock.
3. The asynchronous traction elevator, the other detection output (JP1-12 and JP1-13) of SJT-ZPC-V2A is used to control independent system stop subsystem, JP1-14 directly connect to the middle of the door loop, short connection detection whether to seal the door lock. Because of the other detection output (JP1-12 and JP1-13) of SJT-ZPC-V2A (VM1) control independent stop subsystem, when the door locks sealed part be in danger, triggering the UCMP protection, comply with the safety requirements. In the case of all the rear door plans, the same explanation will not be repeated.

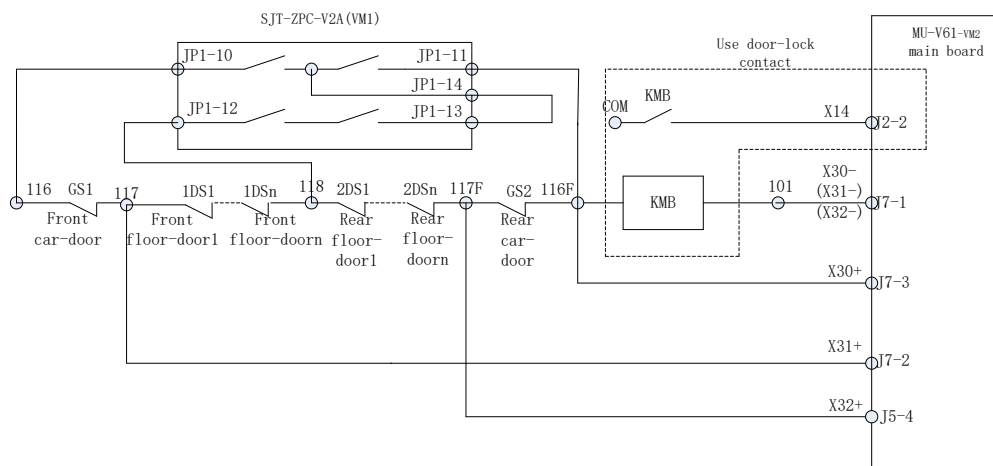
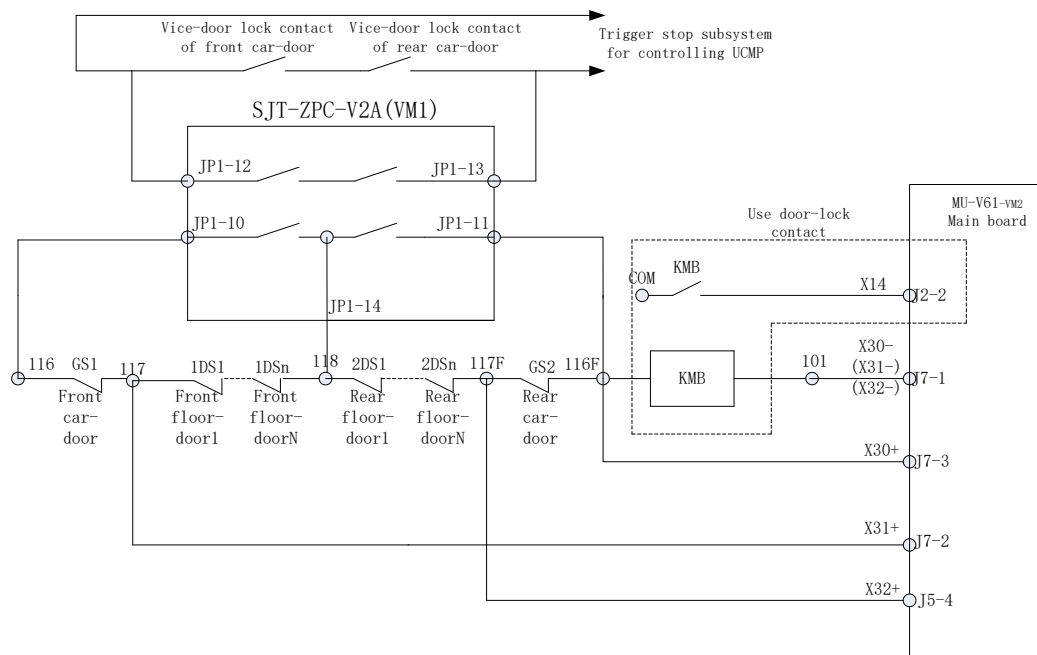

Figure F12.2 rear door mode; floor/car-door short connected detection plan (Suitable for synchronous traction machine)



**Figure F12.3 rear door mode; floor/car-door short connected detection plan (Suitable for asynchronous traction machine and combined with UCMP stop subsystem)**

Incorrect operation of floor-door or car-door ((floor-door be shorted, or car-door be shorted) detection;

- In order to accord with the new national standard (or new inspection rules), the floor-door or car-door is short connected respectively, which can be detected effectively and stop normal operation. As shown in figure F12.3, the safe circuit board (SJT-ZPC-V2A (VM1)) must be installed, and Advance Door Open function or Re-leveling function is required to be enabled. (F4-06-19 or F4-06-20 must be set to ON).
- While the elevator is running with advance door open or door open re-leveling function (Safety circuit board works, so the lock door opens) . when the front door opens, it will detect whether the X31 and the front closing door limit are released effectively. If the effective release does work, that proves front floor-door and car-door, and the door-lock closing signal(front door close limit) is correct. Next time the system will operate normally.
- While the elevator is running with advance door open or door open re-leveling function (Safety circuit board works, so the lock door opens) . when the rear door opens, it will detect whether the X32 and the rear closing door limit are released effectively. If the effective release does work, that proves rear floor-door and car-door, and the door-lock closing signal(rear door close limit) is correct. Next time the system will operate normally.
- During the elevator is running with advance door open or door open re-leveling function, if the X31 signal and front door close limit or the X32 signal and rear door close limit are not released effectively (If the front door is opened, the front door should be checked, and the back door is the same. If the two doors open at the same time, it will be detected simultaneously.) , or After opening the door completely in un-inspection state, the main board will output Y0 signal to control the safety circuit board to short the door lock and check whether the X31 signal and front door close limit or the X32 signal and rear door close limit are released, if not released, the system will output No. 92 fault (floor-door or car-door short circuit fault or adhesion of closing in place signal), forbid the elevator to continue operating normally, It is necessary to enter the condition of inspection or power-off to clear the fault.

## F12.2. V9 Series Elevator Integrated Controller Floor/Car Door Bypass and Operation Alarm Plan

### F12.2.1. Relevant Requirements in National Standard 7588.1

- 5.12.1.8 Floor-door and rear-door bypass device.
- 5.12.1.8.1 In order to maintain floor-door contacts, car-door contacts and door lock contacts, bypass devices should be installed on the control panel (cabinet) or emergency and test operation screens.
- 5.12.1.8.2 The device shall be used to prevent accidental use of switches, or plug and Socket combinations, through permanently installed mobile mechanical devices (such as covers, shields, etc.). The combination of the switches and plugs and sockets should accord with the requirements of 5.11.2 electrical safety devices.
- 5.12.1.8.3 The word "bypass" should be marked on or near the floor-door and car-door bypass devices. In addition, the bypassed contacts should be identifiers based on the principle icons.

#### Note:

As a choice, the symbols shown in figure F12.4 can be used together with identifiers on the electrical schematic diagram.

DS —— Name instance on the wiring diagram.

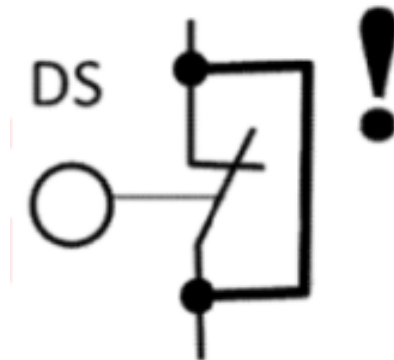

Figure F12.4 by-pass pictograph

The action state of the bypass device should be clearly marked.

The following functional requirements should be met;

- a) Normal operation control is invalid, normal operation includes any operation of automatic door with power operation.
- b) The bypass floor-door closed contact (5.3.9.4, 5.3.11.2), the floor-door lock contact (5.3.9.1), the car-door closed contact (5.3.13.2) and the car-door lock contact (5.3.9.2)
- c) The floor-door contact, and the car-door contact cannot be bypassed at the same time.
- d) In order to allow the car operates after the bypass car-door closes the contacts, an independent monitoring signal is provided to confirm that the car-door is in the closed position. This requirement is also applicable to the sharing of car-door closing contacts and car-door lock contacts.
- e) For manual floor-door, the floor-door closed contact (5.3.9.4) and the floor-door lock contact cannot be bypassed at the same time.

- f) The car can only run in the inspection operation (5.12.1.5) or emergency electric operation (5.12.1.6) mode.
- g) During operation, the hearing signals on the car and the scintillation lights on the bottom of the car should be work. The auditory signal below the car one meter is not less than 55dB(A).

### Pattern test rules for the new type control cabinet;

#### Floor-door and car-door bypass device

In order to maintain the floor-door, car-door and door lock contacts, a bypass device should be provided on the control panel or emergency test screens. The device shall be a permanent installation that prevents accidental use of a switch through a mechanical movement (such as a cover or helmet), or a plug and socket assembly that meets the requirements of an electrical safety device. "Bypass" should be marked on or near the floor-door and car-door bypass device, the action state of the bypass device should be easily identified, and the contacts which have been bypassed should also be marked according to the symbol on the schematic. The bypass device should also meet the following conditions;

- (1) Capable of terminating normal operation control including any automatic door operation.
- (2) The floor-door closing contact, the floor-door locking contact, the car-door closed contact and the car-door locking contact are allowed to be bypassed.
- (3) Floor-door contact and car-door contact cannot be bypassed simultaneously.
- (4) In order to allow the car to run after the by-pass car-door, an independent monitoring signal can be provided to check the closing position of the car-door. This requirement is also applicable to the situation that closed contact of the car-door combines with the lock contact of the car-door.
- (5) When floor-door is in manual, Floor-door closed contact and car-door locking contact cannot be bypassed simultaneously
- (6) The car can only run under inspection mode or emergency electric operation mode.
- (7) When the car is running, the car can produce an audible signal, and the flash of the car's bottom is shining.

### F12.2.2. SJT-PLB-V1 bypass circuit board

#### 2.2.1 specification size

The size of the bypass circuit board is 72mm\*60mm, it can be fitted to the clamping rail with the use of the slot. It can also be fixed by bolts alone and fixed hole  $\phi 3$ (mm).

#### 2.2.2 function description

The bypass circuit board is specially used for the bypass floor/car-door. The detailed method is shown in F12.2.3.

#### 2.2.3 interface description

## Appendix 12. Floor/Car Door Short-circuited Detection and The Plan for Bypass Operation Alarm

SJT-PLB-V1 has 4 terminal pins, two 8 pins, two 7 pins. JP1-2 and JP2-2 are used to switch the bypass state, JP1-1 and JP2-1 are used for connection with the control cabinet.

**Table F12.1 SJT-PLB-V1 interface description**

terminal	Pin	Definition	Explanation
JP1-1	JP1-1_1	Bypass alarm output	Connect door lock and alarm signal.
	JP1-1_2	Bypass alarm public terminal	
	JP1-1_3	Bypass alarm output	
	JP1-1_4	--	
	JP1-1_5	Front car-door input	
	JP1-1_6	Front floor-door input (front car-door output)	
	JP1-1_7	Rear floor-door input (front floor-door output)	
	JP1-1_8	Rear car-door input (rear floor-door output)	
JP1-2	JP1-2_1	Bypass alarm output	The bypass terminal is used in conjunction with JP2-2. When the system is in normal state, the plug is inserted on the JP2-2, the bypass state is inserted on the JP1-2, the JP2-2 plug is pulled out, the top seven terminals on the left side of the JP1-2 will seal the car-door, the JP2-2 plug is pulled out, and the seven terminals on the right side of the JP1-2 will seal the floor-door.
	JP1-2_2	Bypass alarm public terminal	
	JP1-2_3	Bypass alarm output	
	JP1-2_4	--	
	JP1-2_5	Front car-door input	
	JP1-2_6	Front floor-door input (front car-door output)	
	JP1-2_7	Rear floor-door input (front floor-door output)	
	JP1-2_8	Rear car-door input (rear floor-door output)	
JP2-1	JP2-1_1	Main board by-pass input	Connect the signal in the control cabinet.
	JP2-1_2	Main board by-pass input public terminal	
	JP2-1_3	Inspection state	
	JP2-1_4	Inspection state	
	JP2-1_5	Spare	
	JP2-1_6	Spare	
	JP2-1_7	Spare	
JP2-2	JP2-2_1	Bypass state	The bypass terminal will be equipped with a plug inserted on the top, and the pins will be short to 1-2, 3-4 and 6-7 three pins respectively. Plugging the plug into JP1-2 can achieve bypass function.
	JP2-2_2	Bypass state	
	JP2-2_3	Inspection state	
	JP2-2_4	Inspection state	
	JP2-2_5	Spare	
	JP2-2_6	Spare	
	JP2-2_7	Spare	

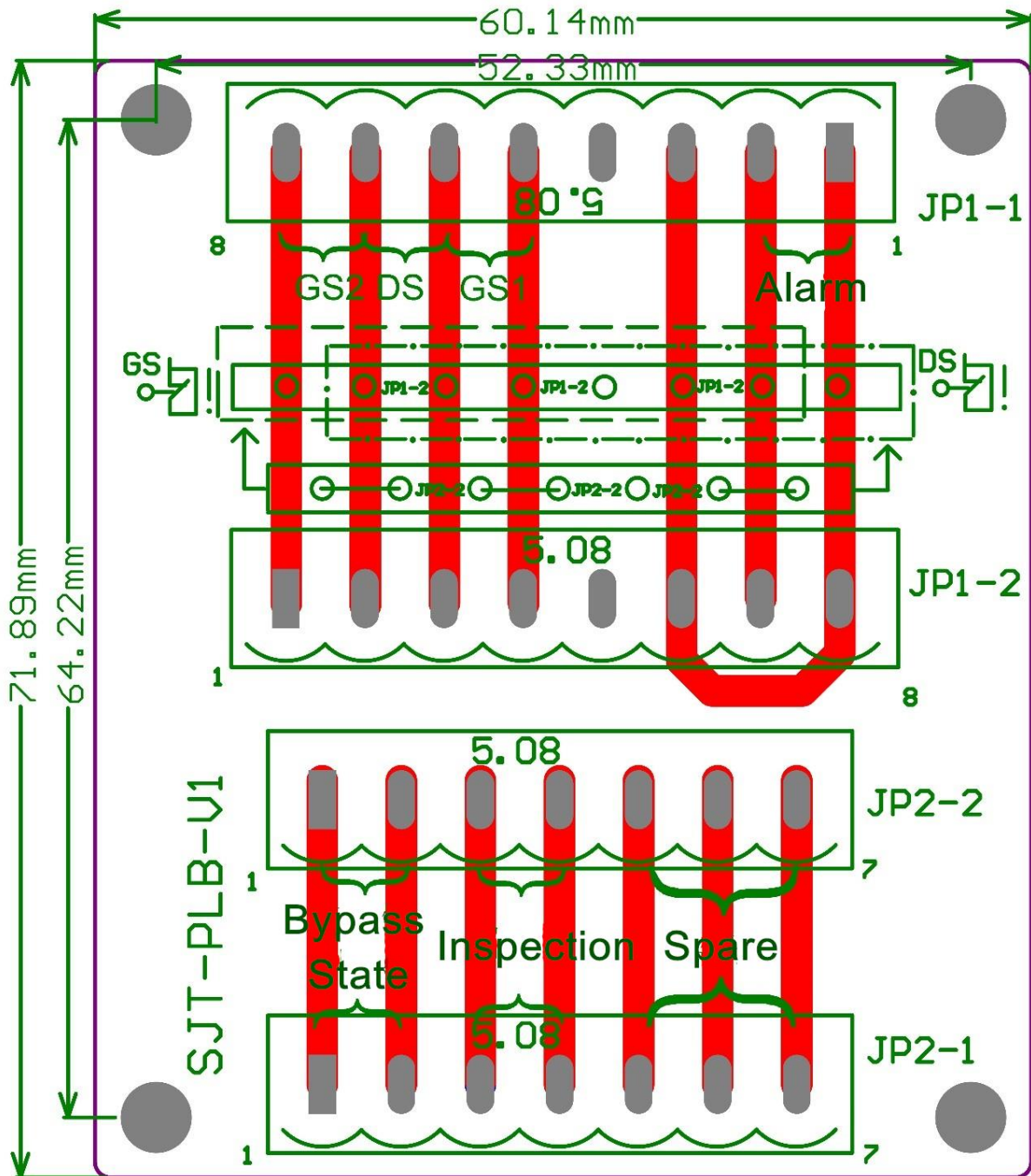

Figure F12.5 SJT-PLB-V1 bypass circuit board structure diagram

F12.2.3. Floor/car-door bypass plan (suitable for V9 series elevator integrated controller)

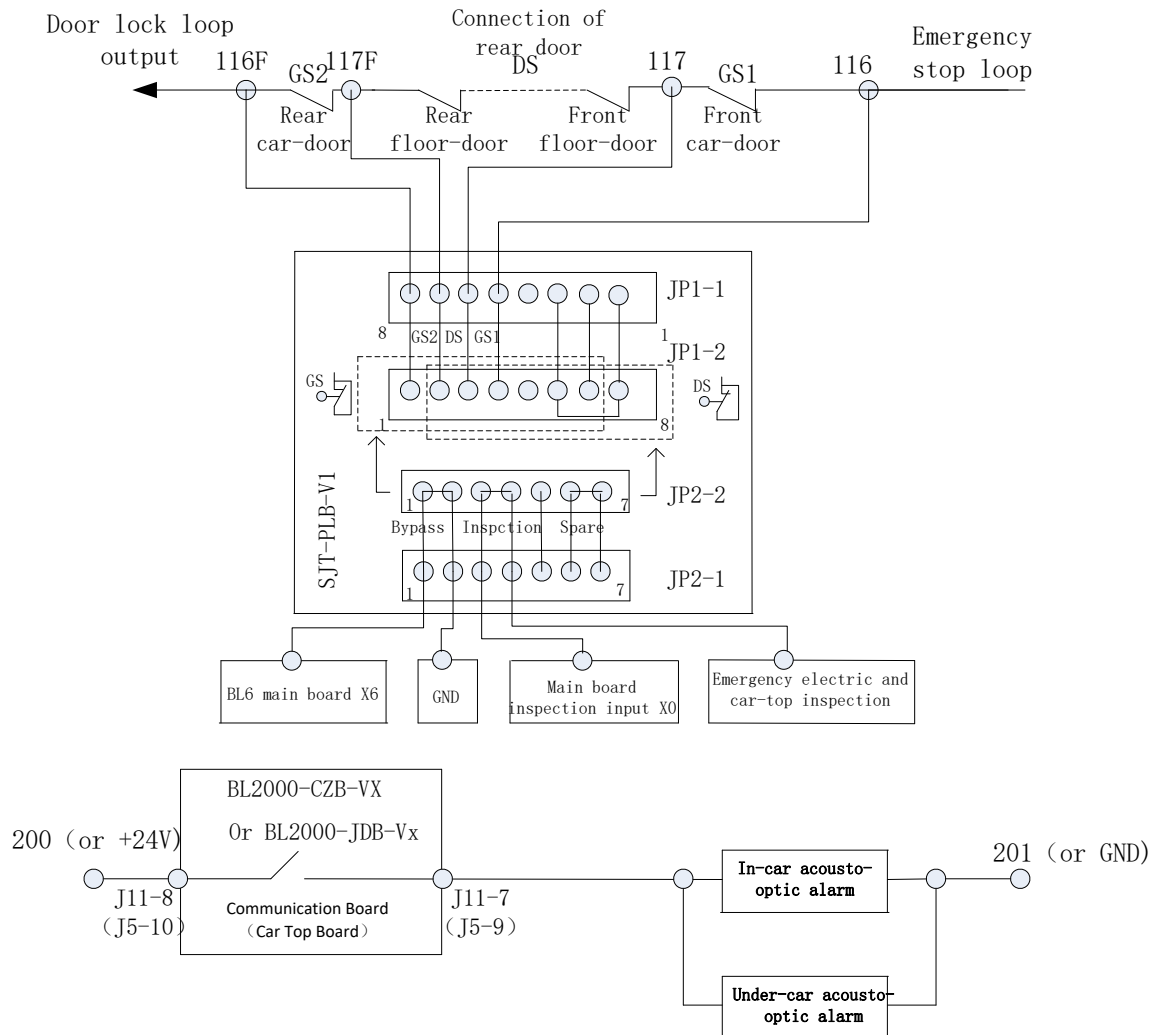

Figure F12.6 V9 series elevator integrated controller rear door bypass plan

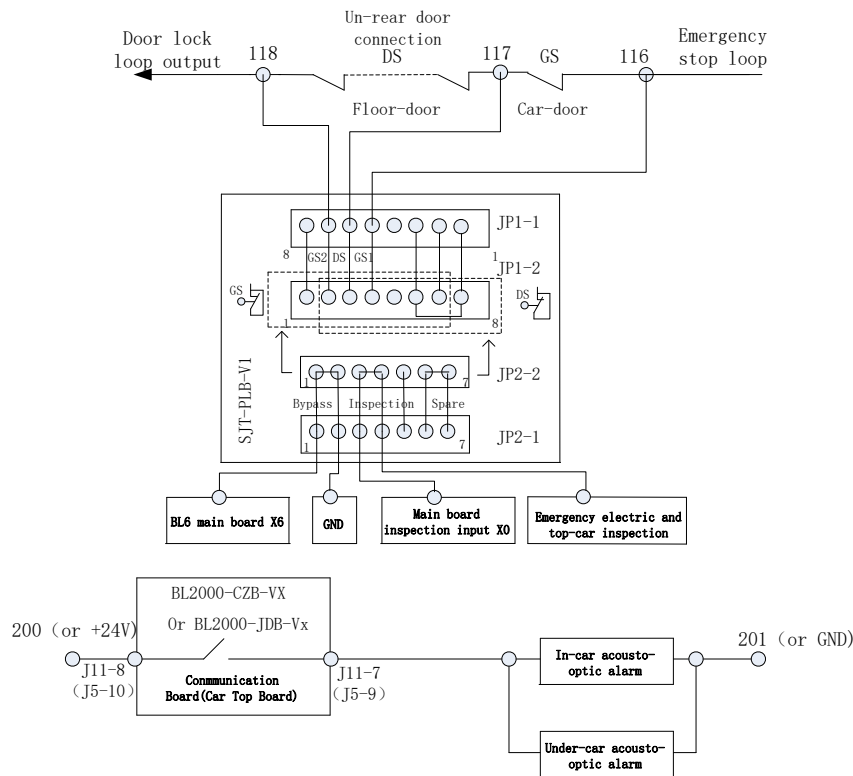

Figure F12.7 V9 series elevator integrated controller un-rear door bypass plan

Explanation:

- 1、 Using a SJT-PLB-V1 dedicated bypass circuit board, such as figure F12.6 and figure F12.7, to use a 7 pin JP2-2 and an 8 pin JP1-2 plug-in with a 7 pin plug (out of factory) to achieve bypass operation.
- 2、 When the system is in normal condition, the plug is inserted on the JP2-2;When in bypass state, the plug is inserted on the JP1-2.
- 3、 Pull the JP2-2 plug, insert the front seven terminals on the left side of the JP1-2 to seal the car door, pull the JP2-2 plug, insert the rear seven terminals on the right side of the JP1-2 to seal the floor-door.
- 4、 As long as the JP2-2 is removed, the inspection circuit will be disconnected, and the X6 bypass feedback signal will be cut off, forcing the system to be in the inspection state and prohibiting normal operation.
- 5、 Left inserted seals car-door and right inserted seals floor-door. The floor-door and car-door cannot be sealed at the same time.
- 6、 F4-07-2 is set to ON (canceling upper and lower limit input functions, using X6 as by-pass input). When in bypass state, the integrated motherboard X6 detects the by-pass input effective, it will control the communication board or car top board output when running, and it will activate the in-car/under-car acousto-optic alarm device(Attention; For BL2000-CZB-V10 communication board, The original definition of J11-8/9 is overload output, which can be set to bypass alarm output or overload output through the jumper, and the new program will be bypass output by default.
- 7、 X6 bypass signal must be used in inspection state. If bypass input is effective in non-inspection state, the system will report ER91 failure and inspection can be eliminated.

V9 and its OEM model, F4-06-16 set to ON (accord with new standard or new gauge must be set) to use the door closing limit (Front and rear door closing limit when in rear door mode) as an independent monitoring signal to check whether the door is in the closed position.

## Appendix 13 Leveling Adjustment inside The Car

When F4-07-29 is set to ON, all floors can be adjusted floor by floor, which can be directly adjusted inside the car by special operation.

### F13.1 Function Description

After the hoistway learning is completed, the debugger will run the elevator floor by floor, measure and record the height difference between the hall-door ground and the car-door ground of each floor. This deviation can be adjusted by the hand-held operator, and also can be quickly adjusted inside the car through a special combination key, so that no need to adjust the magnetic plate in the hoistway.

### F13.2 Leveling Adjustment of Combined Key Operation Inside the Car

#### 1) Entry mode

Under the condition of the driver mode and door opening, press the door opens key and internal selection for 10 seconds, enters the leveling adjustment fast mode, the bottom internal selection is to reduce the current position of the car, the top internal selection is to improve the current position of the car. During the adjustment, the display panel in the car no longer displays the current floor number, but it displays the current correction value of leveling adjustment. The initial value is 50, more than 50 means that the car position is raised, if less than 50, which means that the car position is reduced. The display value of the car varies with the user's addition and subtraction.

#### 2) Exit mode

When the closing button in the car is pressed, or the driver mode switch to automatic mode, the display board and the system will withdraw from the current special adjustment mode, restore the floor display and restore the normal operation mode.

#### 3) attention

**The top floor and the bottom floor cannot be non-stop floor. There should be an internal selection button, otherwise, it is impossible to adjust the floor level quickly in the car. It is necessary to use the operator to adjust the height adjustment value of the corresponding floor in parameter FE-01~FE-64. The default value is 50, and the adjustable range is Up and down 50 millimeters each.**

## Appendix 14 Evacuation Operation of Generator

### F14.1 Special function

F4-07-10	ON; when the generator is running in duplex/group mode with generator, the elevator will return to the base station in turn. Elevator A will return first and then Elevator B will return.
F4-07-11	ON; when the generator is running in duplex/group mode with generator, after the elevator returns to the base station in turn, which is set to ON will resume to normal service.

### F14.2 Functional description

Mode 1; If the power supply capacity is large enough, and multiple elevators run simultaneously. Energy feedback will be cut off.

Mode 2; if the power supply capacity is small, and the elevator runs one by one. Energy feedback will be cut off. For example; 1# elevator runs, other elevators wait. 1# after the 1# elevator is in place, send out the operation instructions to the 2# elevator, the 2# elevator operates, and the other elevator waits. And so on.

### F14.3 Specific operation instructions

- 1) F4-07-10=OFF, when the system suddenly loses power, if the elevator is equipped with ARD (when the power supply is supplied, the mainboard X18 input is valid), the elevator will enter ARD mode. If the elevator is outside the levelling zone, the door should level to the floor nearby, then be opened and maintained according to the speed of self-rescue operation. If the elevator is in the staircase state, open the door immediately and keep it, turn off the car lighting and fan after the door is in place; when the power is restored, the system is put into normal operation. The elevator cannot run ARD in inspection mode or emergency stop mode.
- 2) In parallel or group control, setting F4-07-10=ON, when the standby power supply is working, the input motherboard X18 is effective, and the elevator goes into ARD operation (generator operation).  
 The elevator will be forced down / returned to the bottom by emergency speed (single-floor minimum speed under operating parameters). After the elevator landing / return to the bottom and the door has been closed, it will automatically run back to the base station, open the door and keep it after the elevator level to the floor, close the car lighting and fan after the door is in place. The door does not allow any operation including the closing button is completely invalid, the door button is valid, to protect / avoid the user to be locked inside the elevator.  
 When the elevator being forced down / returned to the bottom by emergency speed, the speed of the elevator runs down to the speed of the inspection, and the car goes to the bottom and level to the floor then opens the door. If the bottom floor is the base station, and the car lighting and the fan are closed after the door is opened. No Internal operation is allowed, including the closing button is also invalid. After emergency landing, the bottom floor is not the base station, the elevator will run to the base station floor, and the car lighting and fans will be closed after the door is opened. No Internal operation is allowed, including closing button is also invalid.

## Appendix 14. Evacuation Operation of Standby Power Supply

---

The single minimum speed under running parameters is the emergency speed of Series Elevator Integrated Controller, which should be set less than 1 m / sec and less than rated speed.

- 3) The generator is used in parallel and group control mode. Each elevator first returns to the base station floor in accordance with the lift number (the base station floor and the fire protection floor should be set to the same, otherwise, it could not run correctly.); if an elevator has fault, the elevator will remain unmoved. When all the elevators that have no fault return to the base station floor, the elevator which was setting F4-07-11 to ON will be set back to normal service. If the elevator has not returned to the base station floor because of the fault, after other elevators have returned to the base station floor, it will return later too. If any one of elevators has been restored to normal operation, it must wait until all the resumed elevators stop to the nearest target floor, the fault restore elevator will go back to the base station floor. Then other elevators restore service operation. If parallel group control is unable to communicate, because the capacity of the generator is insufficient, the operation of each elevator is unknown, and the elevator will not use the generator to return.

## Appendix 15 VIP Function

### F15.1 Special Function

F4-07-17	Set to ON, enable VIP mode, receive the 63 floor up call or down call of the outside calling board to enter the VIP recall mode.
----------	--

### F15.2 Functional Description

- 1) The upper or lower call signals of the calling board with the address of 63 are used as VIP input signals, which are installed next to the normal calling board. That means, there are two outside calling boards on the VIP floor, one for the ordinary call board and one for the VIP call board.
- 2) Start the VIP calling board and enter the VIP function.
- 3) The controller no longer responds to the outside call, and at this time, if there is still unfinished registration, a new selection can still be registered until all registered internal elections are completed to ensure there are no people in the car, then the controller uses an empty car (no inside selected instructions) to pick up the VIP.
- 4) The VIP floor allows multiple entries to be registered, but only goes to the nearest floor in the VIP mode. After the arrival, it opens the door automatically and leaves the VIP mode.
- 5) After the VIP function is started, the elevator must automatically withdraw from the group control function. After the end of the VIP function, the group control function is resumed automatically.

### F15.3 Specific Operation Instructions

Add the VIP mode. F4-07-17 is set to ON, enter the VIP recall mode when the receive address is set to 63 levels of upper or lower call requests. (The call board instruction of the external call board is no longer used as the 63 level up and down call command after the VIP function is switched on as the input signal of the VIP floor.) The elevator system no longer responds to new external calls and internal selection. After the service is selected, it will return to the VIP floor to open the door and waiting, then the system will enter the VIP waiting mode (dedicated). During the VIP mode, the up and down answering lights on the 63 level have been kept on lighting. After the user enters, the door is closed according to the closing button, and the service VIP does not respond to the external call during the election period. After the elevator service is selected in a VIP, the VIP has already left the car, then the service is restored normally to the other floor. The VIP floor can be adjusted by the parameter F0-04 VIP floor.

## Appendix 16 Earthquake Operation

### F16.1 Functional Description

- 1) The earthquake sensor is triggered to activate the earthquake operation function. Avoid placing weights in a balanced position so as to avoid smashing cars.
- 2) First to judge the current position of the elevator, if there is a risk of overlap between the car and the weight during the nearby stopping process, the controller should control the elevator running up, and level to the nearby floor over 2 meters to stagger the weight.
- 3) The elevator stops and opens the door automatically.
- 4) The earthquake sensor must be reset manually and cannot automatically reset.

### F16.2 Specific Operation Instructions

When the main board X21 earthquake input signal is valid, the elevator clears all the registered external call signals, and then open the door to evacuate the passengers at the nearby floor. If the special function parameter F4-07-15 is set to ON, after opening the door, a buzzer sounds every second. When the door is evacuating, the elevator control system determines the current position of the car. If the balance position interval between the weight and the car in the hoistway is found (within the range of positive and negative 2 meters), the elevator enters the circumvention balance position mode, the car tries to close the door, and after the door is closed, the elevator automatically registers an internal selection instruction of the parked floor above the balance position (which can automatically avoid the nonstop floor). Then run upwards to the parked floor to open the door. Then it reports ER25 fault and waiting for the manual reset earthquake monitoring switch to resume the ER25 fault.

## Appendix 17 Australian Fire Fighting Mode

### F17.1 Standard Basis

AS 1735.1-2003 modify the description of firefighting mode in Appendix A (A2.14.7) of 1-2006.

Description of firefighting mode in AS 1735.1-2003 original text 14.3.5.2.

### F17.2 Functional Operation Description

In view of the Australian fire control standards, the integrated control system has a firefighter running function when the Fire fighting mode is set to 2, and provides two new signal inputs to meet the three switches described in the above two standards (turn off, open and start), The original car's direct driving signal is used as an open / off input signal for the firefighter's operation. The signal is normally open, closed and effective, and enters the firefighter's driving mode. When you need to increase the "start" signal in the car, use the special signal of the original car, the original special in the fire operation is invalid, as the "starting" button, when the fire operation, hold and keep the "start" signal, the elevator car will automatically close the door, before the door closed, loss the "start" switch, then the door resumed to open to the opening position, and the registered internal selection is cleared. If the "start" switch is kept until the door is completely closed, then the elevator starts running, then the "start" button is released, and the elevator continues to run.

## Appendix 18 Using the Main Board Keypad to Carry Out self-learning operation process

### F18.1 Hoistway Learning fast operation process description (ESC+UP combined button trigger)

Drive the elevator to the lower limit position in inspection mode and press the ESC and UP keys on the keypad at the same time for 10 seconds, the digital block shows L2\_\_ (The symbol “\_” is actually 2 spaces.).

L2

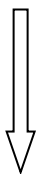

Loosen the combination key and press Enter key, the elevator will automatically carry out hoistway learning operation.

The current floor count is displayed in the "\* \* \*" position of the digital block during the self hoistway learning operation process.

L \* \* \*

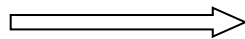

LE\* \* \*

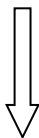

If hoistway learning is failure, the digital block displays corresponding fault number, press the confirmation key to quit learning process.

L3

"L3".

After successful learning, the digital block automatically restored to display

If there is a fault, please see the **8.2 Hoistway Parameter Self-Learning Faults**.

Press the ESC key three times continuously, quit the hoistway learning menu, and return to the main menu.

**F18.2. synchronous motor static initial angle tuning fast operation process description (ESC+ combined button trigger)**

If the motor is prepared to make motor initial angle tuning with load, please ensure that the elevator car is in the right position in the hoistway, and it is convenient to run a distance in the mode of inspection after the successful learning of the motor. Press and hold on both the ESC and Enter keys on the keypad for 10 seconds, the digital block shows Γu\_1.(The symbol “\_” is actually 1 space)

Γu 1

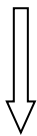

Loosen the combination key and press Enter key, the elevator will automatically enter the self-learning preparation mode.

Γu 2



Driven CPU response self-learning request successfully and get ready for it, then the digital block automatic switch display as follows;  
(If the digital block continues to display Γu\_2, that may be because the motor type or the motor self-learning mode is wrong. )

**\* Note; if the self-learning operation is unable to continue, you need to check the parameter settings with the operator.**

Γu 3



Press Slow down or slow down to start the motor's **static initial angle tuning** process. After that, the motor needs to be checked and run for about 3 cycles. If a self-learning failure is produced, the error is reported;

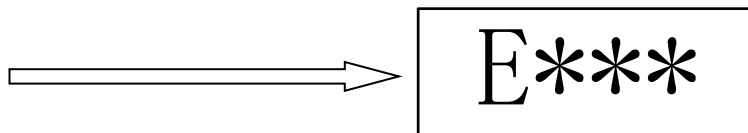

**\* If there is a fault, please see the 8.2 Motor Parameters Tuning Faults.**

Γu 4

Motor's **static initial angle tuning successful**, loosen the slow up or slow down button, the motor self-learning process is over.

Press the ESC key three times to return to the main menu.

## Appendix 19 Direction and Speed Display when Electrical Release Brake and Car Slide

### Brake and Car Slide

When the brake is electrical opened, the 4-digit segmental display on main board enters car slide direction and speed displaying mode.

Elevator goes upward is displaying as positive speed, unit in m/s.

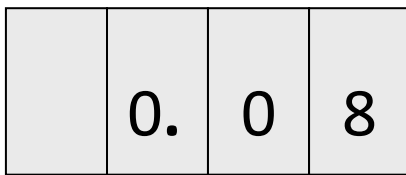

As in figure above, means elevator is going up with speed of 0.08m/s.

Elevator goes downward is displaying as negative speed, with '-' sign and unit in m/s.

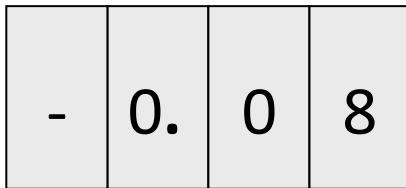

As in figure above, means elevator is going down with speed of 0.08m/s.

For integrated controller with upside down installation, as F4-06-30=ON, the segmental display will automatic adjust the display to shows upside down.

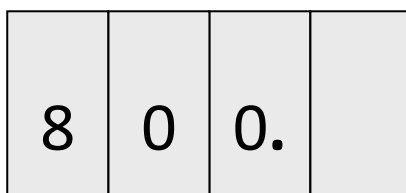
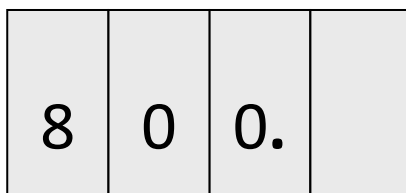

As in figure (already adjusted), indicates respectively car slides upward in 0.08m/s and car slides downward in 0.08m/s.

## Appendix 20 Forced Drive Mode Elevator Instruction

**Note;** 7X26 and later version (includes 26) has Forced Drive mode.

When elevator is forced drive mode, thus, in mechanical perspective there is no counterweight, and the elevator system is equivalent to windlass.

In order to provide more comfortable starting, system usually adopts weighting device and no-load compensation methods to compensate torque during starting.

**Parameter 1:**F9-11[Comp Enable] =1;

**Parameter 2:**F9-00[Max Torq Comp] =adjust according to actual condition;

**Parameter 3:**F9-21[FULL Comp Pro] = adjust according to actual condition.

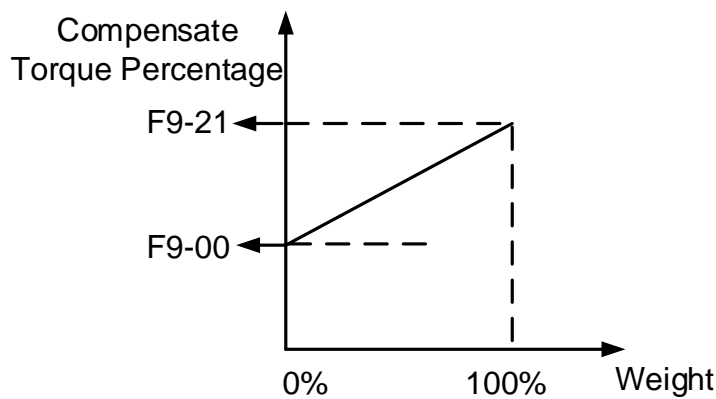

**Figure F20.1 Forced Drive Torque Pre-apply Schematic Diagram**

Adjust method;

1. When light load, adjust F9-00 so that the car does not slip in light loaded. Adjustment rule; open the brake, if car slips down, then increase F9-00; otherwise reduce F9-00.
2. When full load, adjust F9-21 so that the car does not slip in full loaded. Adjustment rule; open the brake, if car slips down, then increase F9-21; otherwise reduce F9-21.

According to the **Forced Drive Torque Pre-apply Schematic Diagram**, the starting torque is single direction in forced drive mode.

When weight is 0%, elevator system has balancing torque =  $F9-00 * \text{Motor Rated Torque} / 100$ ;

When weight is 100%, elevator system has balancing torque =  $F9-21 * \text{Motor Rated Torque} / 100$ .

## Appendix 21 Integrated Controller Manual Door Solution

### 1. Software and Hardware Configuration

**Controller Main Board:** MU\_V61 VT1 series main board

**Control cabinet:** V9 modular control cabinet

**Car Top:** BL2000-JDB-V1X car top board

**Car roof:** SJT-CNT-3C modular car roof box

**Car:** BL2000-ZLB-V6X Command Board

**Retiring Cam:** Installed on car top. Only when the car is in allowable door-lock open zone, the retiring cam can extend out and push the door lock open. Only when the door lock is been pushed open, then the door can be open. When the retiring cam retracts or the car is not in allowable door-lock open zone, if hall door is completely closed, then it will not be open.

**Controller Software:** version 1000\_7125 and later.

### 2. Parameter Setting

- 1) For manual door project, hall door lock and car door lock need to be detected separately. Thus, F4-06-12 set to ON;
- 2) For spared door lock contactor configuration, set F4-06-13 to ON;
- 3) Set F4-06-31 to ON to activate manual door special function;
- 4) F4-06-19=OFF and F4-06-20=OFF to turn of advanced door open and open door releveing functions.

### 3. Wiring Setup

- 1) Hall door has both primary door lock contactor and auxiliary door lock contactor. As elevator is in leveling zone, primary door lock contactor is contacting when hall door is closed, primary door lock contactor is disconnecting when hall door is open. For auxiliary door lock contactor, it is contacting when retiring cam retracts and it is disconnecting when retiring cam extends out.
- 2) X31 (J7-2) is the high voltage input for hall door primary circuit feedback, X30 (J7-3) is the high voltage input for hall door primary and secondary circuits in serial feedback.
- 3) The retiring cam is controlled by main board output Y5 or by car top board front door close output (car top board close door output is simultaneously with Y5 output). Noted, car top board has OC type output, so when it is used for output control retiring cam, it cannot directly connect to the solenoid valve coil. Thus, a relay is needed to interact the control. Main board Y5 is relay output, it can be used directly.
- 4) Main board Y5 terminal, MU\_V61 VM; J4-4, COM; J4-8, Y5  
Car top close door output terminal, BL2000-JDB-V1X; J5-1, COM; J4-6, GM1  
Car operation board terminal, BL2000-CZB-V10; J11-6, COM; J11-5, GM1
- 5) For main board has no Y5 relay, use output Y10 (or Y11) instead to control retiring cam. Set F3-09=5, Y10 (or F3-08=5, for Y11) output logic is same as Y5.

Y10 terminal of main board, MU\_V61 VM; J4-9, COM; J4-10, Y10

Y11 terminal of main board, MU\_V61 VM; J5-1, COM; J5-2, Y11

- 6) When using main board Y5 or Y10 to control retiring cam, 2 additional wires are required in travelling cable than standard control system configuration. If using car top board output to control it, no additional travelling cable wire is required but need an additional relay on car top.
- 7) Due to the require of auxiliary door lock contactor detection, one additional wire is needed in hoistway cable than standard control system configuration.

### 4. Time Sequence Description

- 1) When hall door is open, X31 is invalid. After hall door is closed, X31 is valid, at this time if the run direction is given (register of car call, hall car or inspection run), and the light curtain is not shaded. Then integrated controller main board Y5 relay (original close door output relay) outputs (or car top board close door outputs), the electromagnetic coil is engaged and contracts the retiring cam back. After hall door completely close and the retiring cam is back, X30 becomes valid as the linkage mechanism shall close after the electric retiring cam is fully back. The elevator running conditions are fulfilled, system permits to open the brake and run the elevator.
- 2) No matter the system is in inspection mode or in automatic mode, when electric retiring cam control outputs, if the door lock is not closed in 10 seconds, it will report ER31 and clear all car call and landing call. This error is automatically cleared when door lock circuit successful closes, and the system is back to normal operation.
- 3) When ER31 happens, electric retiring cam stops Y5 output, and the error will reset in 5s. It allows the door to be closed. But if the door lock circuit is not closed for continues 3 times (X30 is invalid), this error will be maintained. This will require hall door open (X31 is invalid), or system power off, or door lock circuit completely closed, to clear this error.
- 4) When hall door circuit is closed and X31 is valid, the system is in conditions to prepare for closing the light. Open the hall door will have the cabin light back.
- 5) Before elevator running, if the light curtain is shaded, the electric retiring cam will not have output (Y5 and car top close door command are not outputting), the elevator cannot operate. During elevator running, if the light curtain is shaded, the elevator will slow down to stop immediately and report error ER54. When light curtain shade is gone and signal recovers, elevator will self-rescue run to leveling zone.
- 6) For manual door elevator, when car stops, if the door is not opened, it must wait for F2-05 (Open Door Time) then can operate next running. The minimum open-door time is 10s, any settings less than 10 will be counted as 10 seconds.

### 5. Additional Instruction

- 1) For retiring cam that is contracting when lose power, which is opposite to Y5 output logic (before elevator running, system outputs so retiring cam can open door; when hall door is closed and run direction is given or elevator is running, system does not output, retiring cam cannot open door). When using Y5 output or car top output, a normal close relay is required to translate the signal. Or using Y10 (Y11) directly as retiring cam lose power output, set F3-09=23 for Y10 output control (or F3-08=23 for Y11 output control) .
- 2) If system does not have retiring cam, more additional wires are needed in traveling cable or

hoistway cable. X31 and X30 on main board need to be short connected. The control logic is identical as description above. But be warned, this configuration has the following and others risks, please take safety precautions accordingly.

- a. Passenger can randomly open hall doors even elevator is not on current floor. There are risks of falling.
- b. Hall doors on other floors beside the current floor, if any door is opened by passengers or other reasons, the door lock circuit will keep open and cause the elevator cannot run.
- c. When elevator is running, if any hall door is opened suddenly, elevator will emergency stops and cannot run. It can only recover when all hall doors are closed. There are risks of trapping people.

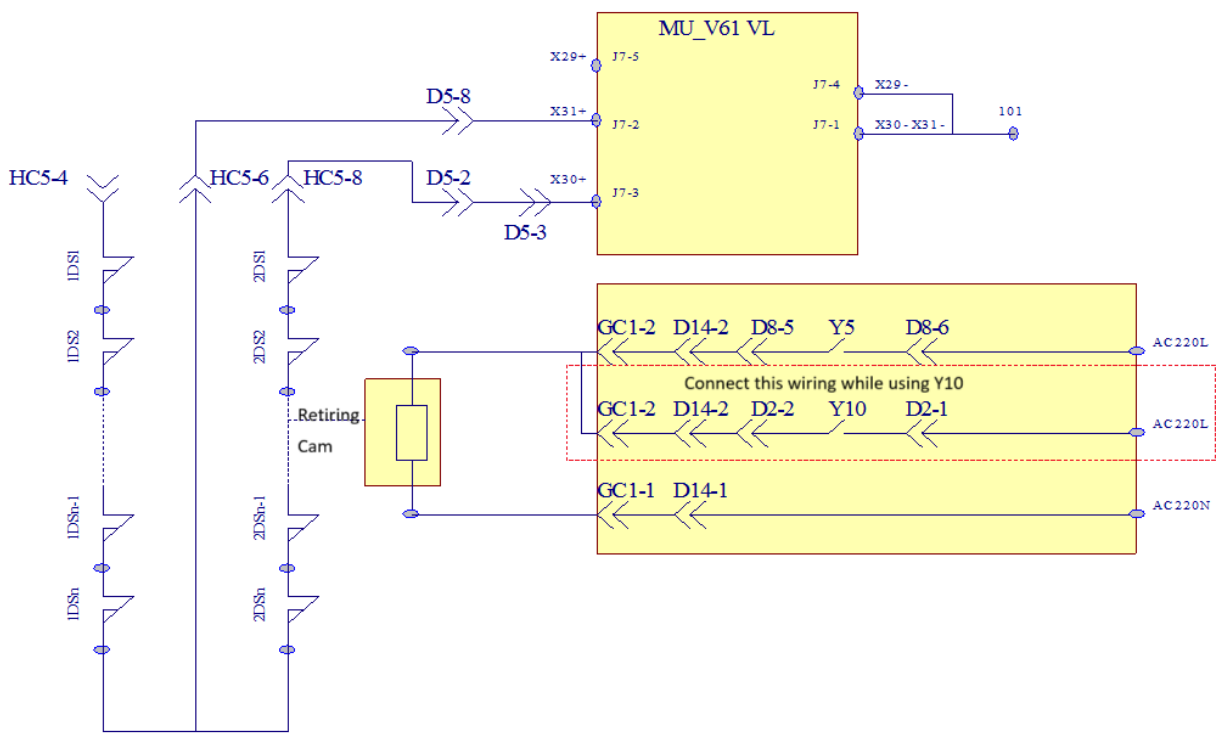

Figure 21.1 Door Lock Circuit Diagram

**Due to ongoing product modification, data subject to change without notice**

---